

ASSEMBLY P/N.-X13986038 PC-20 RL 15" IMP/COLUMNA

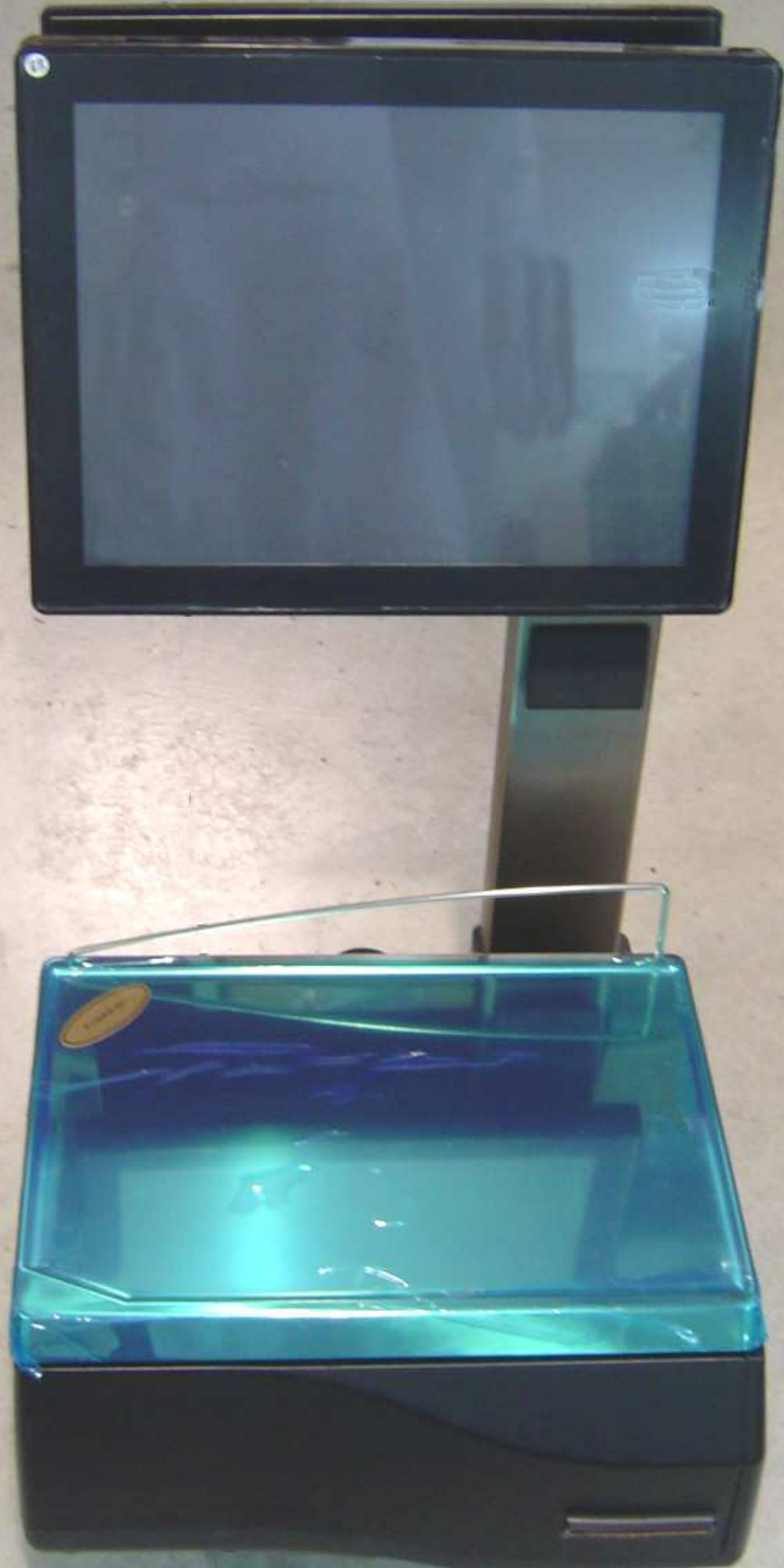

**GUIDELINE ASSEMBLY PC-20 RL 15" IMP/
COLUMNA P/N.-X13986038**

1. ASSEMBLY BASE AND POWER ENTRY
2. ASSEMBLY POWER SUPPLIES AND SWITCH BOARD
3. ASSEMBLY SET LOAD CELL
4. ASSEMBLY PICO ITX BOARD AND CONNECTIONS BADGE
5. CONNECT CABLES
6. ASSEMBLY SET LABEL PRINTER
7. ASSEMBLY DOOR AND COLUMN
8. ASSEMBLY COVER
9. ASSEMBLY UP CROSS AND PUT PAN SCALE
10. ASSEMBLY SUPPORT OF MONITORS
11. ASSEMBLY 15" FRONT MONITOR
12. ASSEMBLY SUPPORT BACK MONITOR
13. ASSEMBLY AND CONNECT SET BACK MONITOR
14. FINISH

1.- ASSEMBLY BASE AND POWER ENTRY (COMPONENTS)

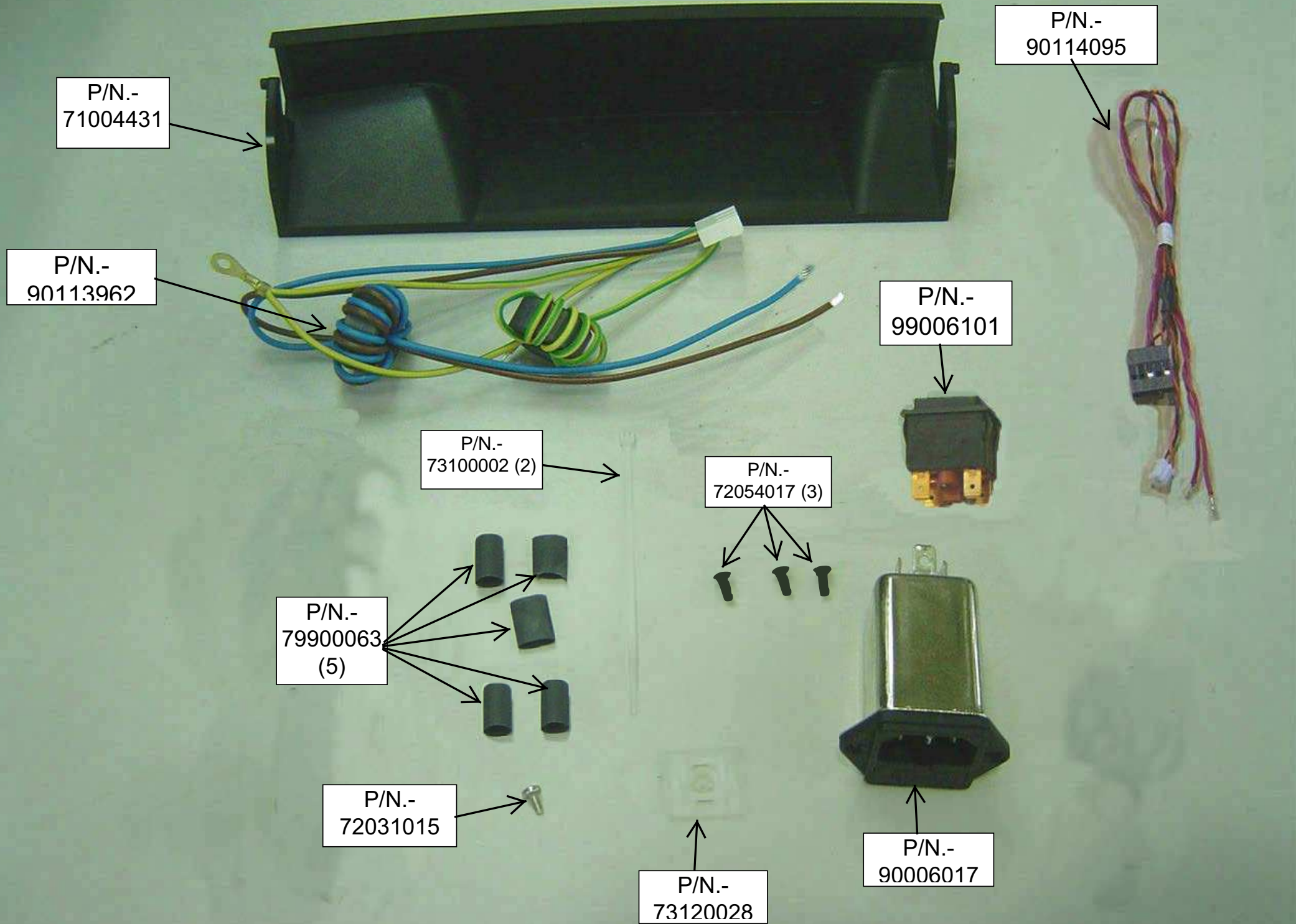

1.- ASSEMBLY BASE AND POWER ENTRY (COMPONENTS)

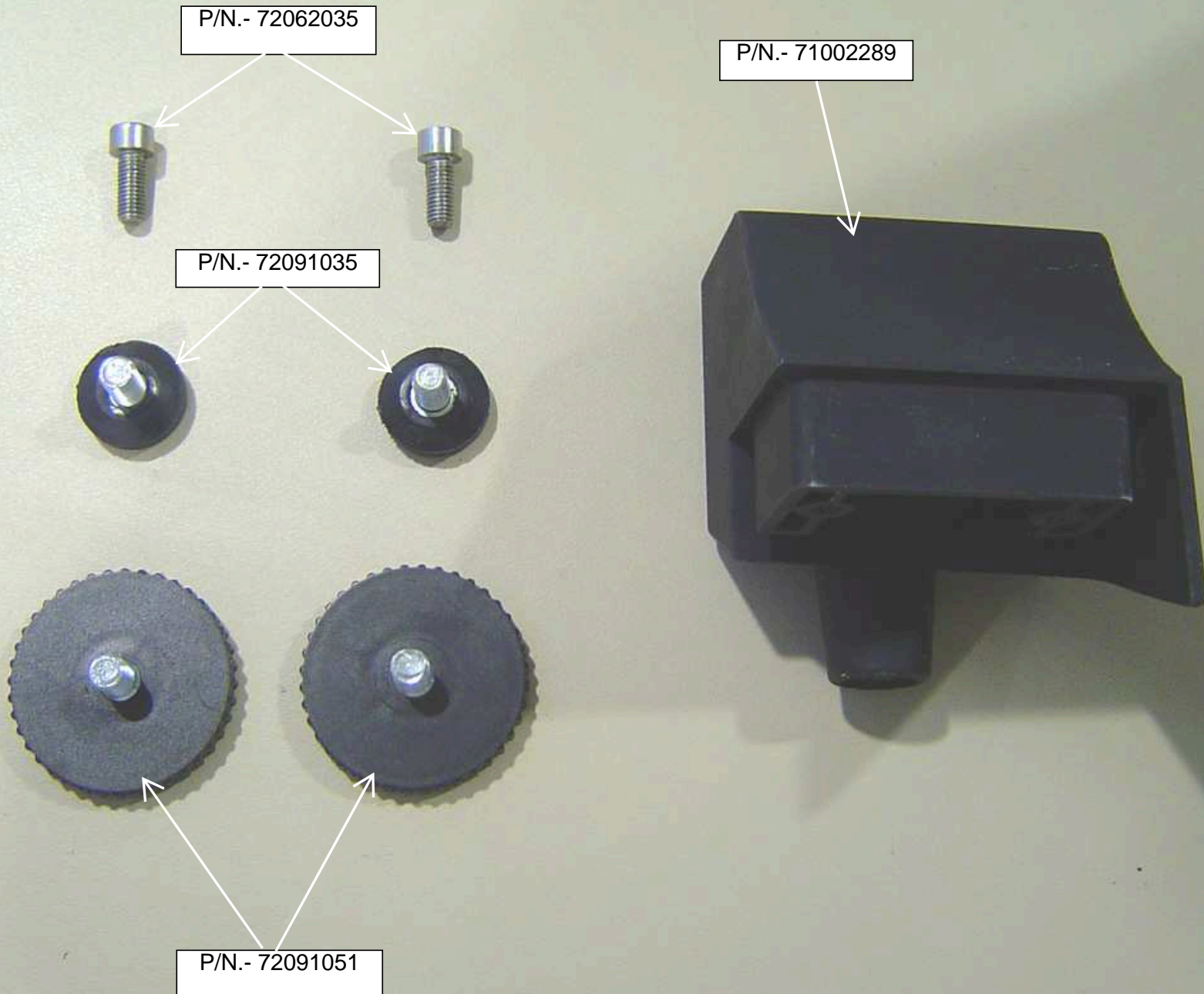

1.- ASSEMBLY BASE AND POWER ENTRY (COMPONENTS)

P/N.- 70000456

P/N.- 70000546

P/N.- 70010205



FUSE 3A

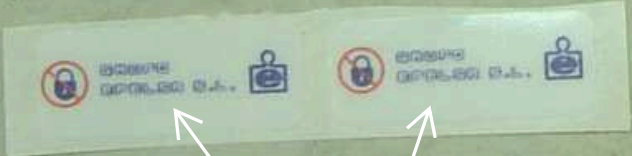

P/N.- 70010155 (2)

SOLDER CABLE P/N.- 90114095
PUTTING SHRINK P/N.-
79900063

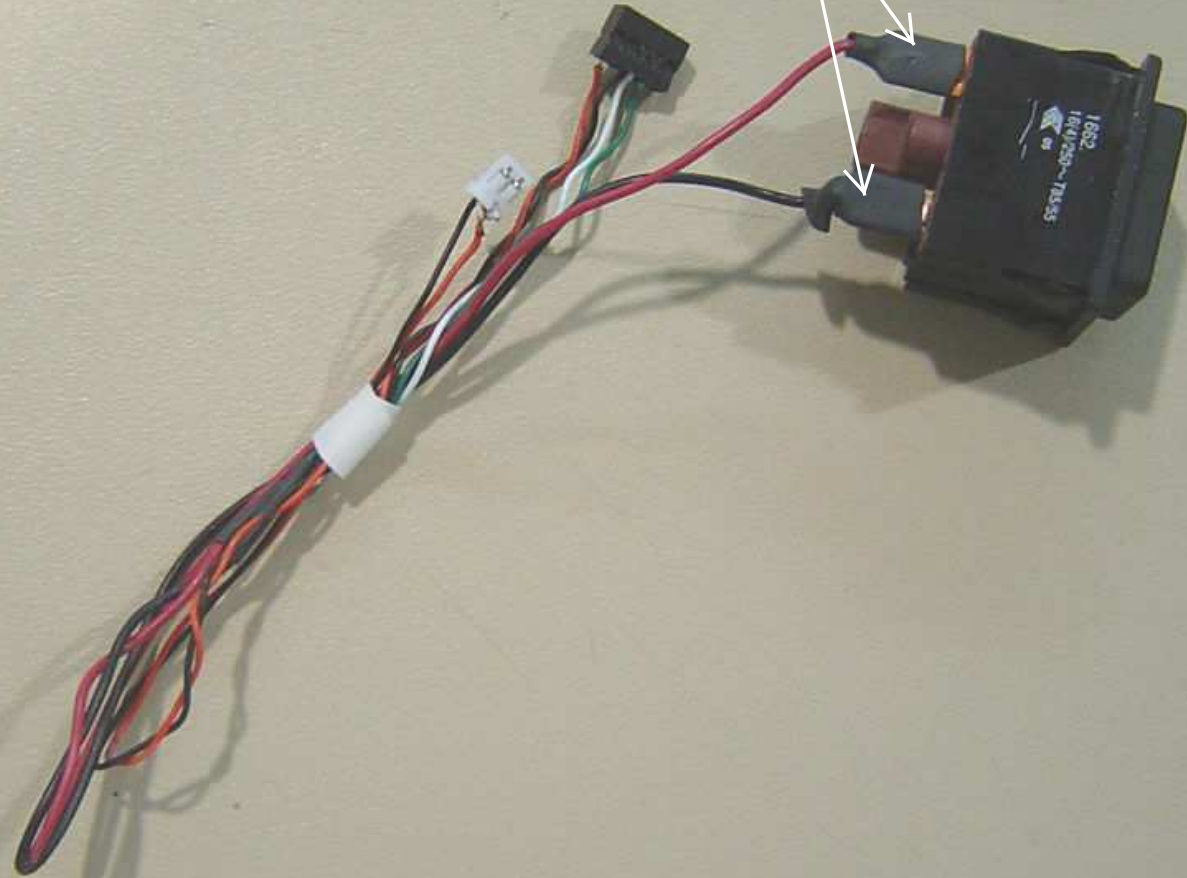

SOLDER THE CABLE P/N.-
90113962 PUTTING SHRINK P/N.-
79900063

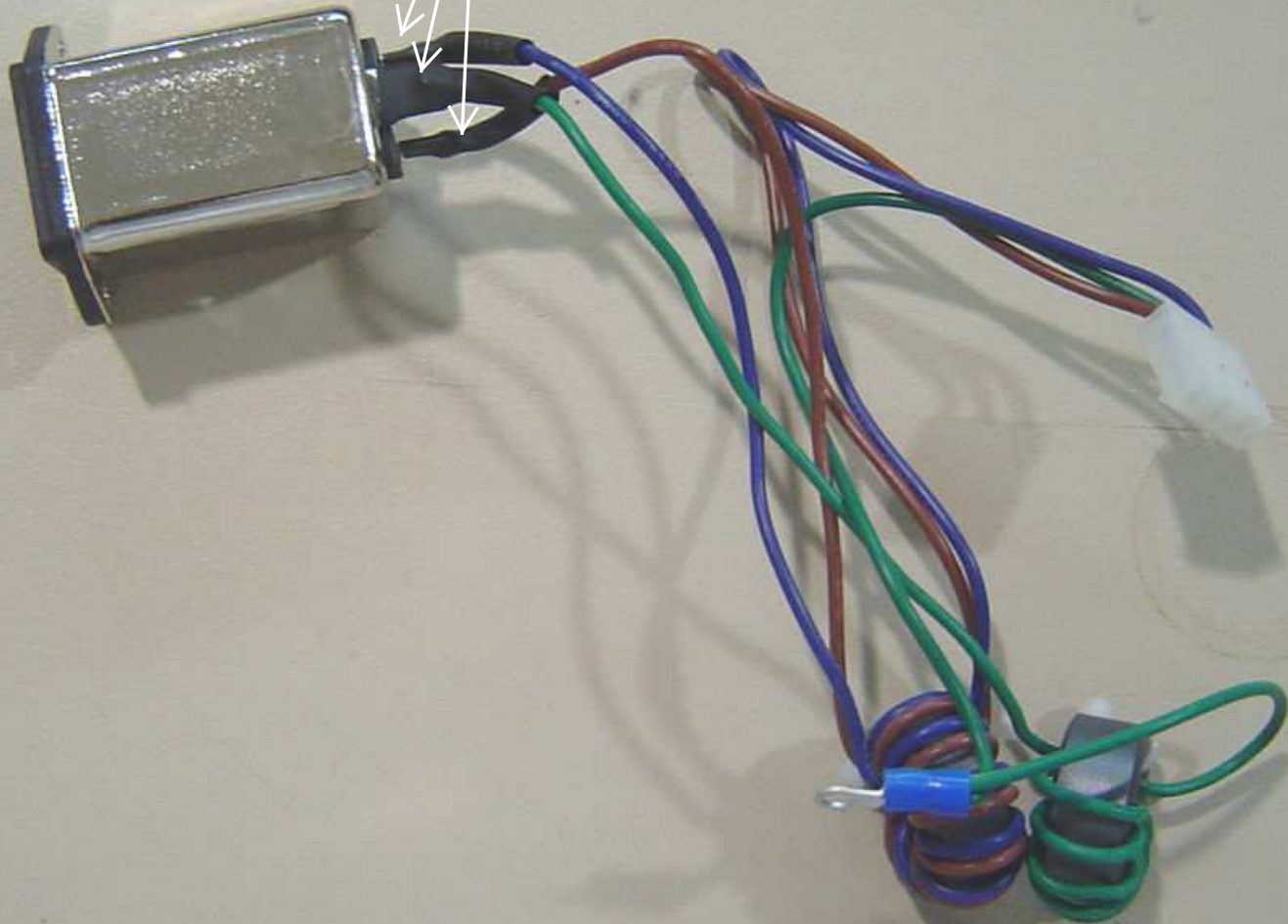

P/N.- 71002288

P/N.-
71002289

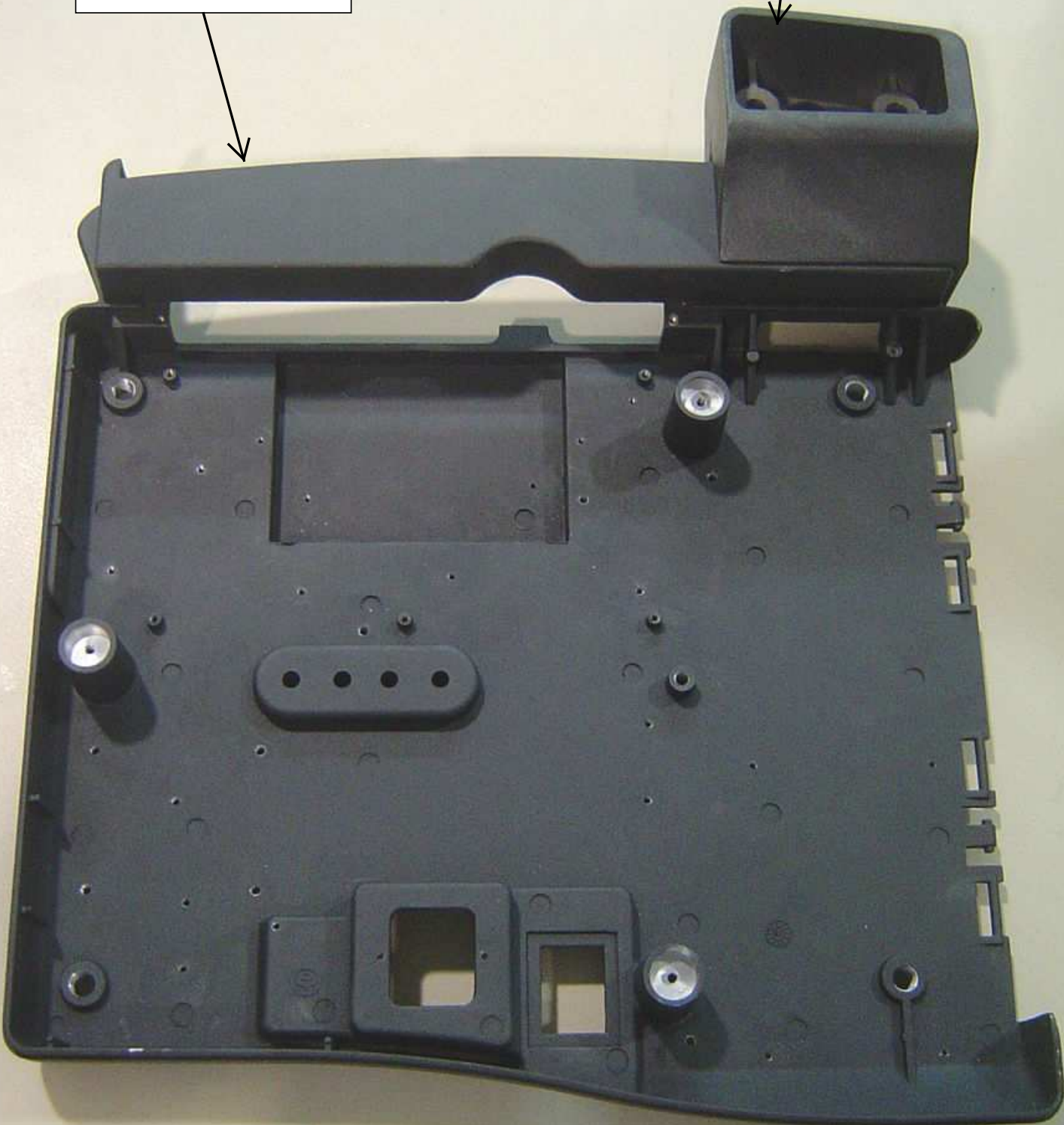

ASSEMBLY THE
PIECE P/N.- 71004379

TIGHTEN THE
FEET P/N.-
72091051

TIGHTEN SCREWS P/N.-
72062035 WITH A
REGULATED TOOL TO A
TIGHTENING TORQUE 11
Nm

TIGHTEN THE
FEET P/N.-
72091035

P/N.-
90006017

PASTE THE
STICK P/N.-
70010205

ASSEMBLY THE
SET ON / OFF
PUSH P/N.-
99006101

PASS THE FERRITES AND
CABLES, OF THE SET
POWER INPUT, THROUGH
THE HOLE AND HOLD
WITH SCREWS P/N.-
72054017

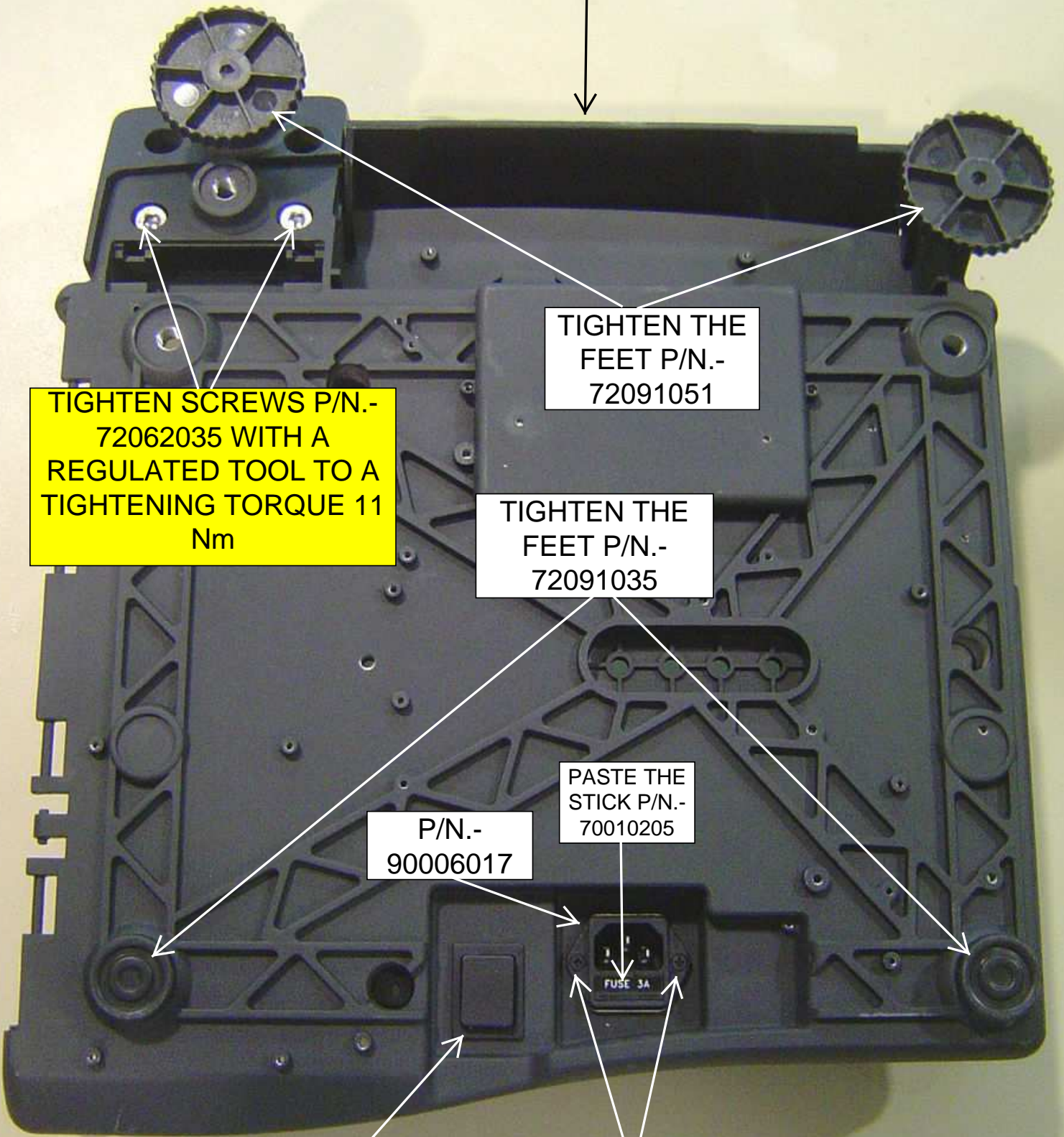

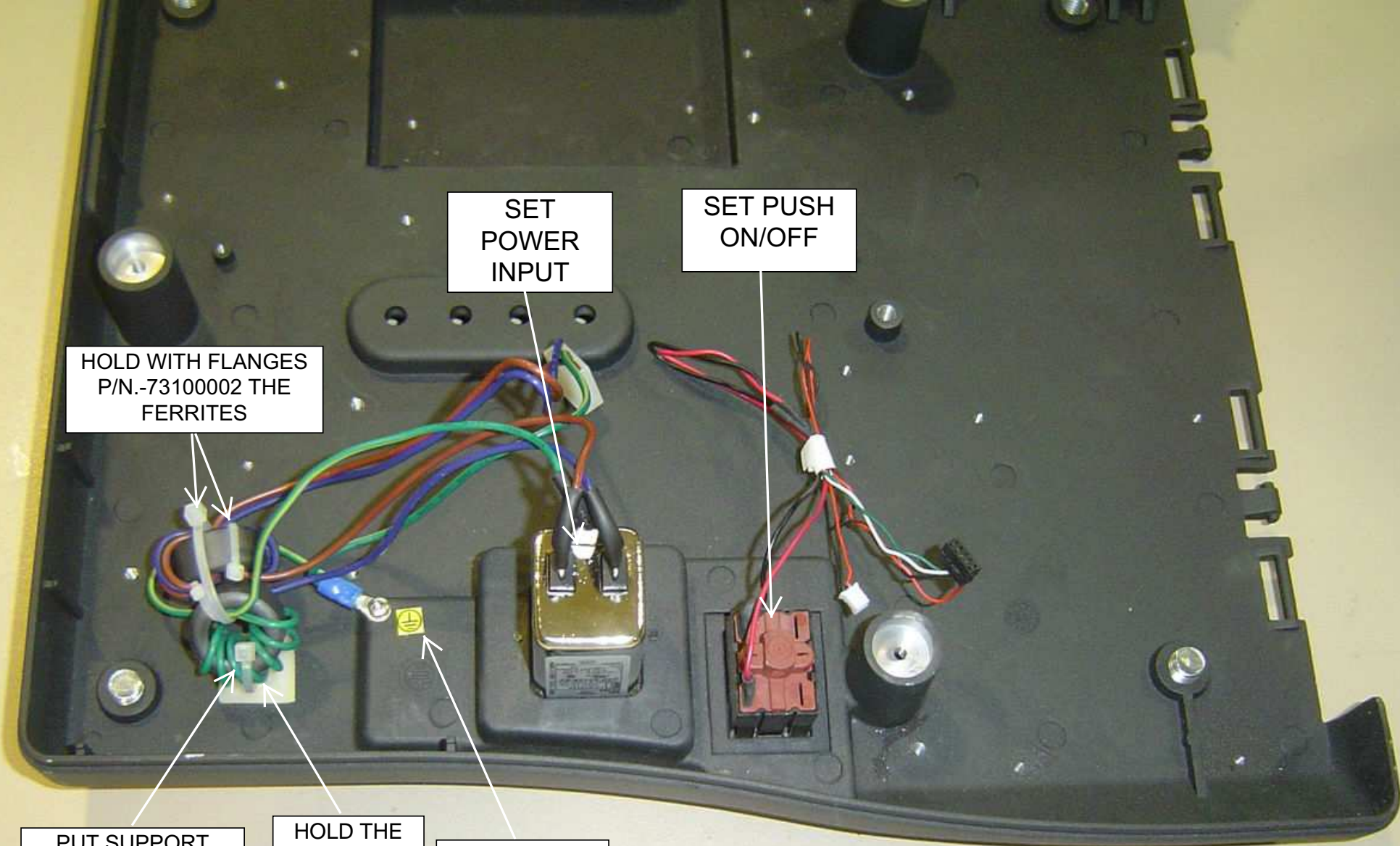

SET
POWER
INPUT

SET PUSH
ON/OFF

HOLD WITH FLANGES
P/N.-7310002 THE
FERRITES

PUT SUPPORT
FLANGE P/N.-
73120028 WITH
SCREW P/N.-
72054017

HOLD THE
GROUND
TERMINAL
WITH
SCREW P/N.-
72031015

PASTE THE
STICK P/N.-
70000546

2.- ASSEMBLY POWER SUPPLIES AND SWITCH BOARD (COMPONENTS)

P/N.-
72031015 (2)



P/N.-
73050004
(2)



P/N.-
72031016
(2)



P/N.- 72091008
(NYLON SCREW)



P/N.-
72031026



P/N.-
71100003
(4)

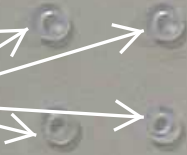

P/N.-
73100002
(2)

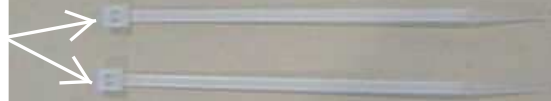

P/N.-
71210408
(2)



P/N.-
19052165



P/N.-
19052167



P/N.-
90114096



P/N.-
19052155



CONNECT CABLE
P/N.- 90114096

CONNECT CABLE
P/N.- 90113962

P/N.- 72031015

P/N.-
71210408

P/N.-
73050004

P/N.-
71210408

P/N.-
73050004

HOLD WITH
FLANGE P/N.-
73100002

PASTE THE
STICK P/N.-
70000456

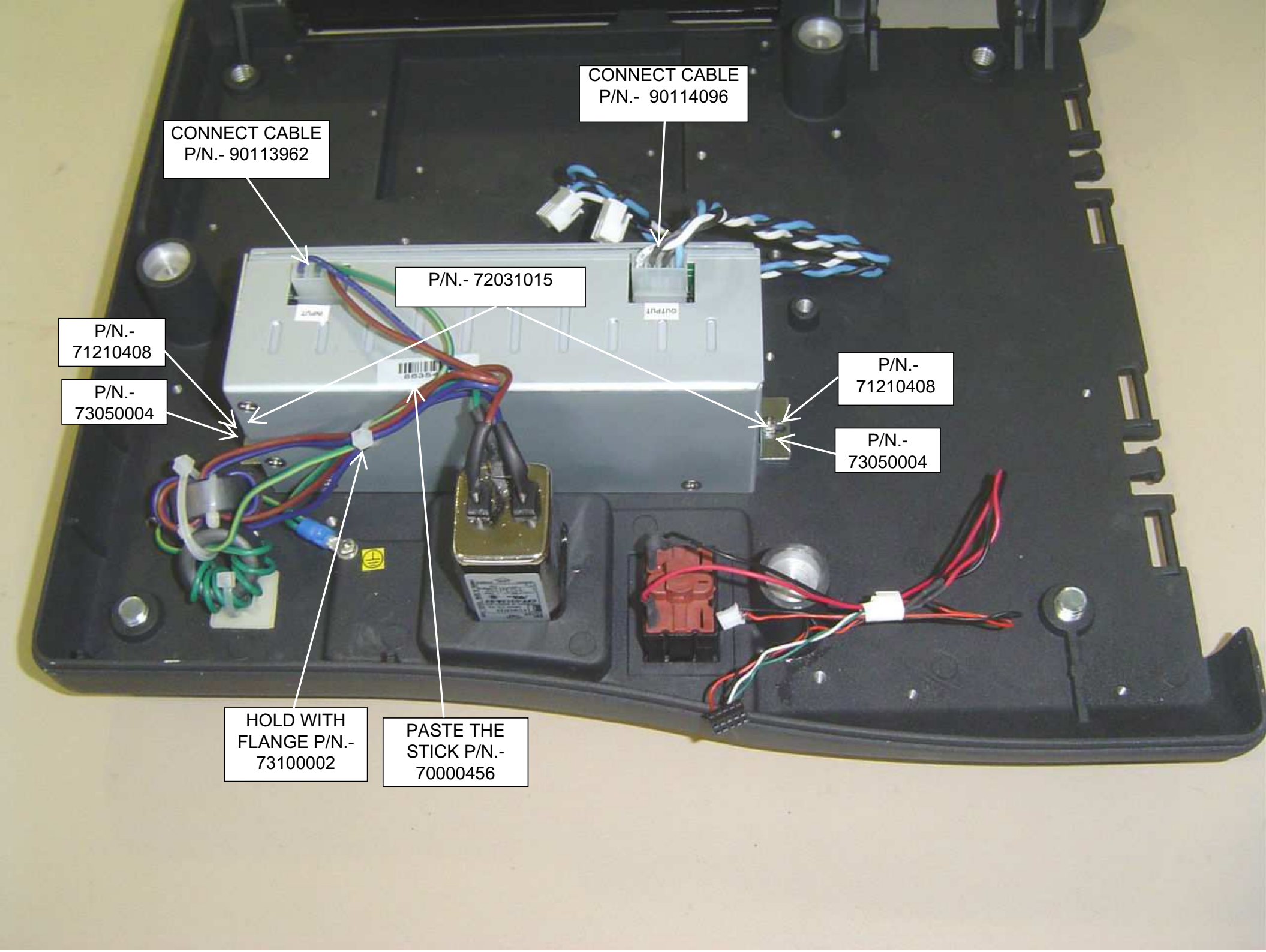

DETAIL
ASSEMBLY
POWER SUPPLY

P/N.- 71210408

P/N.- 72031015

P/N.- 73050004

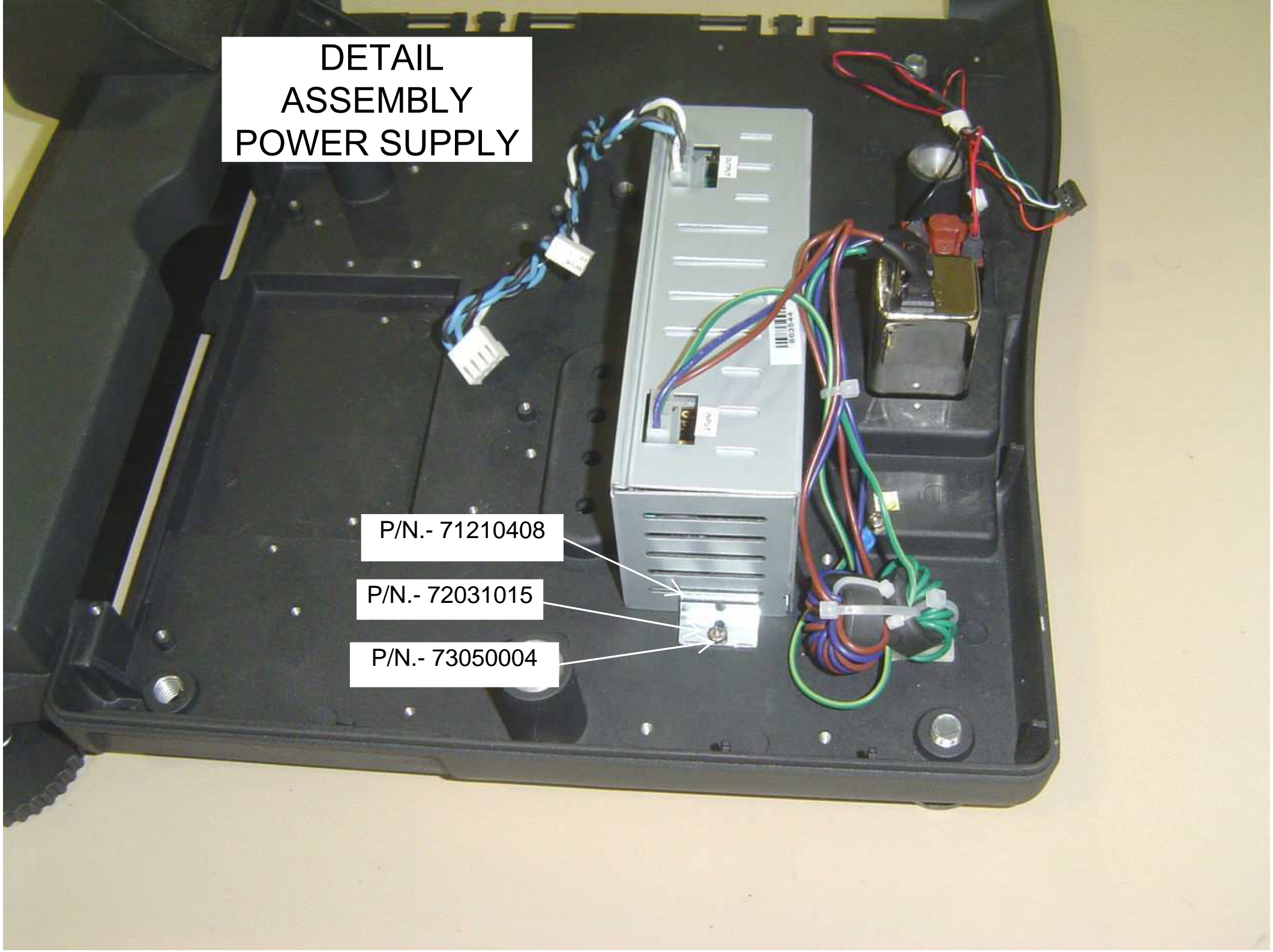

DETAIL
ASSEMBLY
POWER SUPPLY

P/N.- 71210408

P/N.- 72031015

P/N.- 73050004

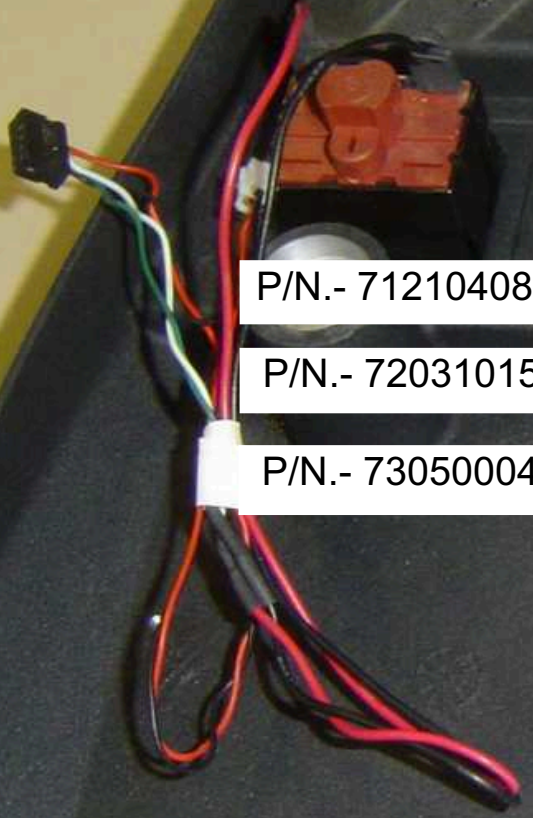

PUT THE POWER SUPPLY P/N.-
19052165 AND HOLD WITH 2
SPACERS P/N.- 71100003, SCREW
P/N.- 72031016 AND SCREW P/N.-
72091008 (SEE NEXT PICTURE)

PUT THE SWITCH BOARD
P/N.- 19052167 AND HOLD
WITH 2 SPACERS P/N.-
71100003, SCREW P/N.-
72031016 AND 72031026
(SEE NEXT PICTURE)

CONNECT CABLE IN
POWER SUPPLY
AND SWITCH
BOARD

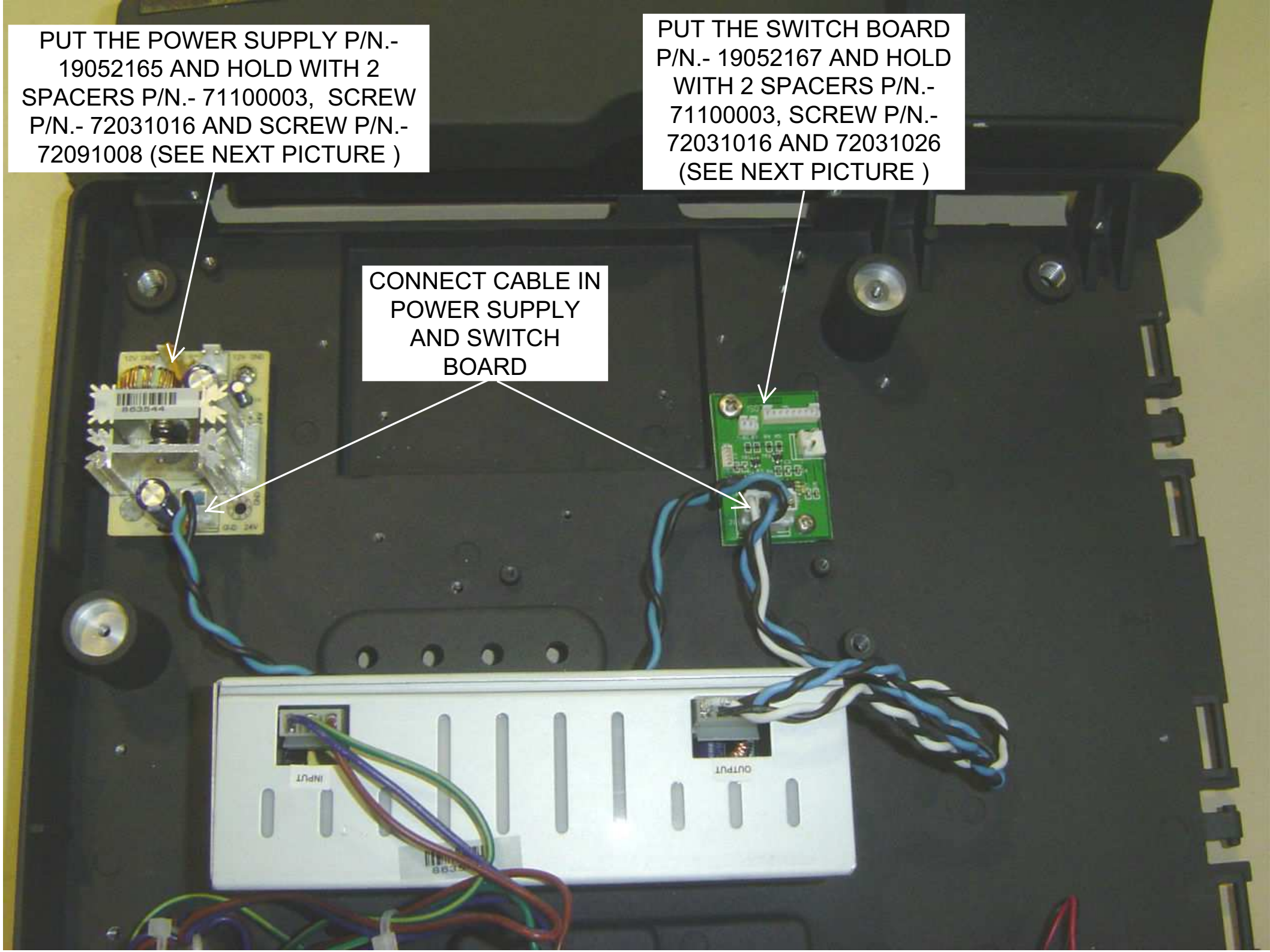

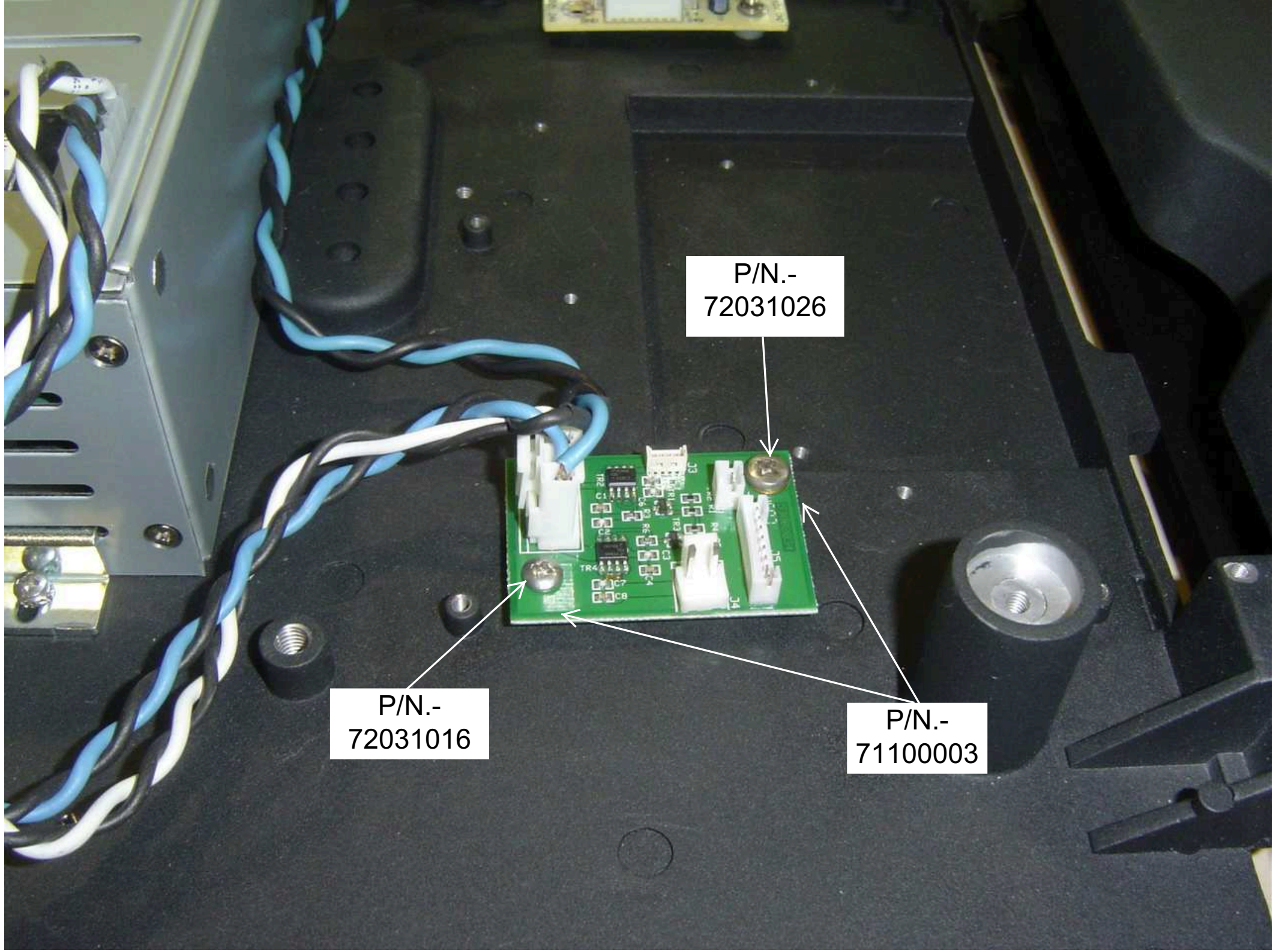

P/N.-
72031026

P/N.-
72031016

P/N.-
71100003

P/N.-
71100003

P/N.-
72031016

PASTE THE
STICK P/N.-
70000456

PUT HERE P/N.-
72091008 (NYLON
SCREW)

P/N.-
71100003

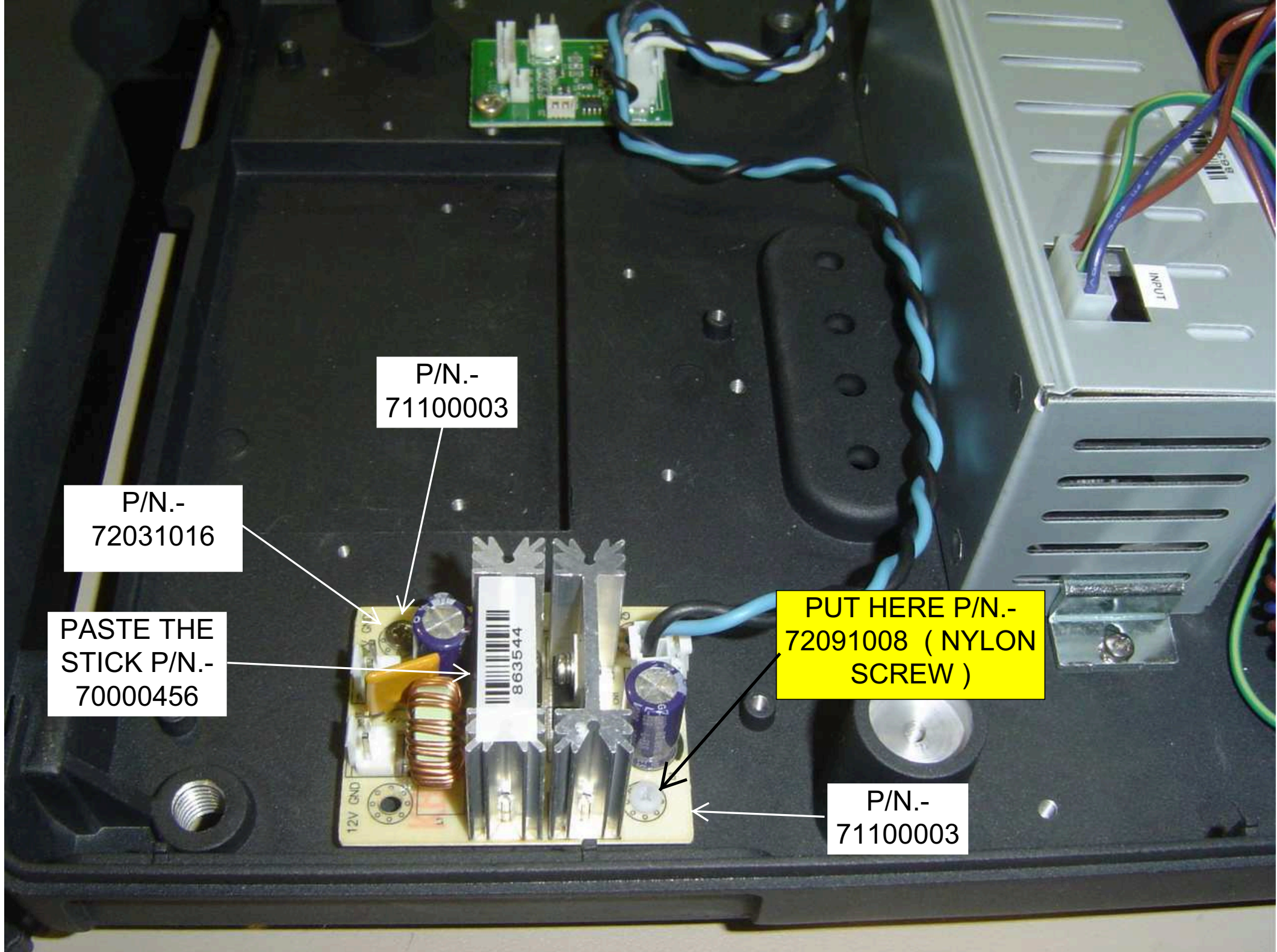

3.- ASSEMBLY SET LOAD CELL P/N.- 97003239 (COMPONENTS)

P/N.- 97003224 (FOR 15Kg SCALE)



P/N.- 72091042 (2)

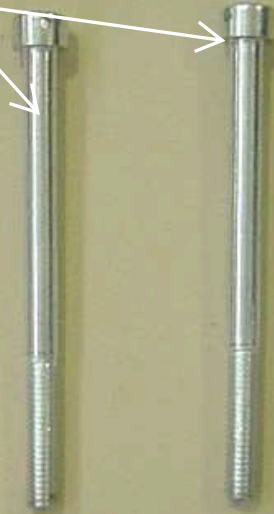

P/N.- 71004335



P/N.- 71101023



P/N.- 93002035



P/N.- 71101022



P/N.- 73003001 (2)



3.- ASSEMBLY SET LOAD CELL P/N.- 97003239 (COMPONENTS)

P/N.-
19016800



P/N.-
71210520



P/N.-
112583

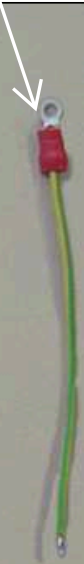

P/N.-
19016900

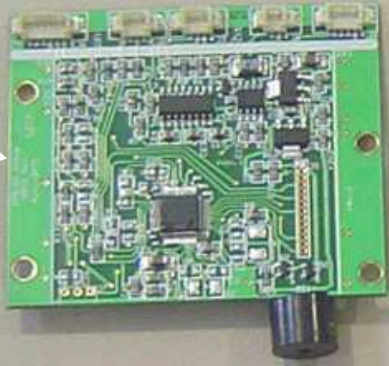

P/N.-
71002295



RIVET P/N.- 72300013
(3 x 16) (4)

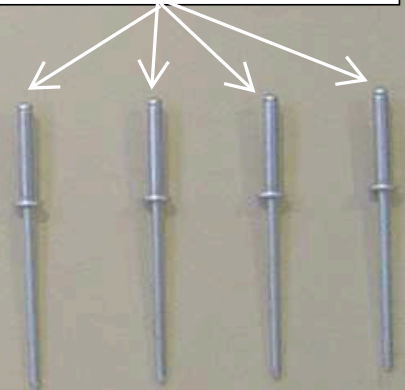

P/N.-
71100003 (4)

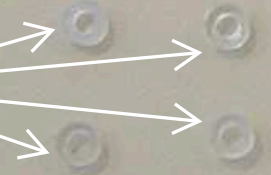

P/N.-
79900061



3.- ASSEMBLY SET LOAD CELL P/N.- 97003239 (COMPONENTS)

P/N.-
90113984



P/N.-
72012039



P/N.-
71210414



P/N.-
72031015



P/N.-
72102009



P/N.-
73050004



P/N.-
73050007





CUT THE WIRES
OF THE LOAD
CELL TO A
LENGTH OF 2 cm



SOLDER DE CABLE P/N.-
112583 TO LOAD CELL
GROUND CABLE PUTTING
SHRINK P/N.-
79900061

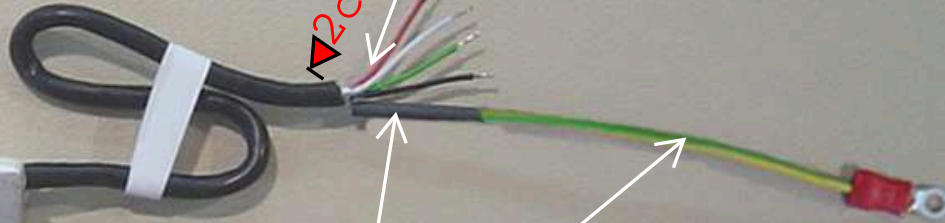

SOLDER THE LOAD
CELL CABLES IN BOARD
P/N.- 19016800

RED

BLACK

GREEN

WHITE

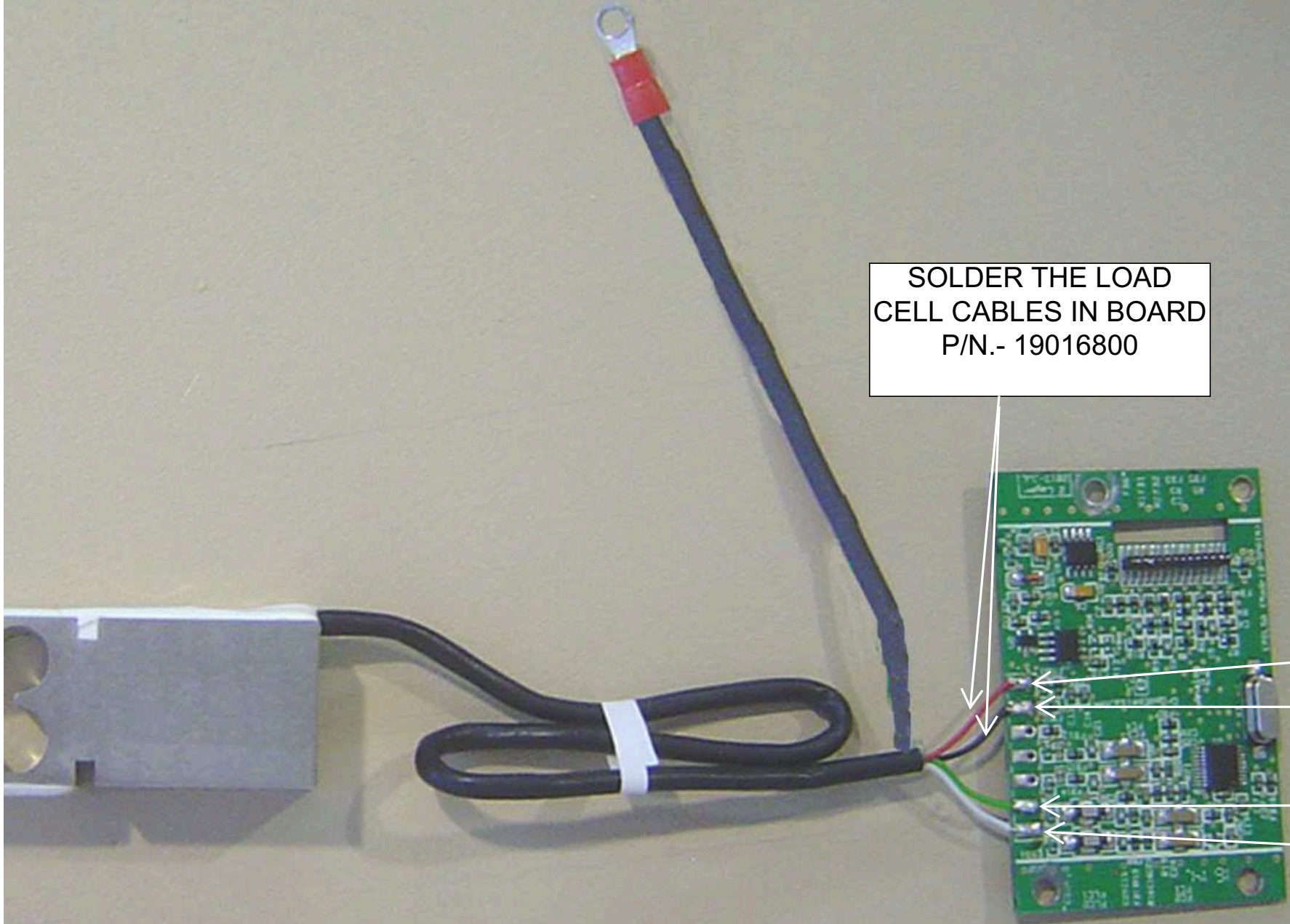

PUT SPACER P/N.- 71100003 AND GUIDE-SCREW TO ASSEMBLY ANALOG BOARD AND BPTC BOARD (P/N.- 19016900). AFTER ASSEMBLY SOLDER PINS IN J5

GUIDE SCREWS

SPACERS

SOLDER 14 PINS AT J5

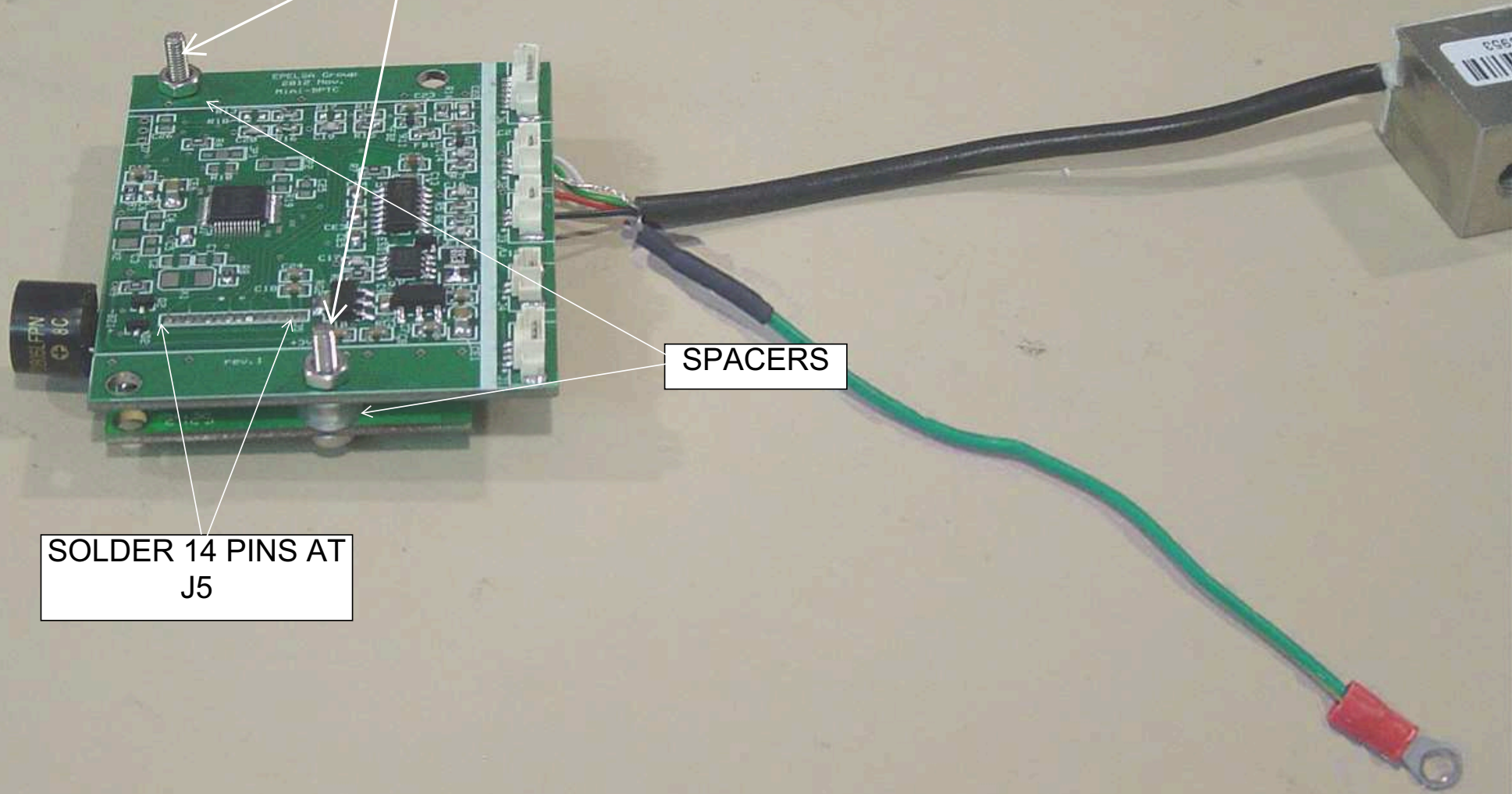

ASSEMBLY SET DIGITAL LOAD CELL

HOLD ALL
TOGETHER WITH 4
RIVETS

RIVET P/N.-
72300013

P/N.- 71002295

P/N.- 19016900

P/N.- 71100003

P/N.- 19016800

P/N.- 71004335

P/N.- 71210520

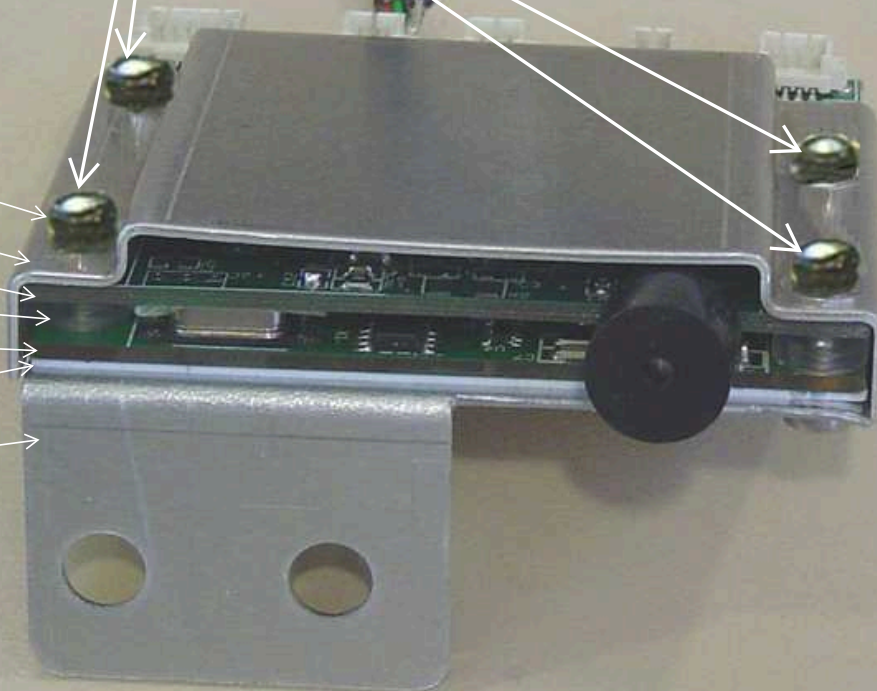

JOIN THE SET
WITH 4 RIVETS

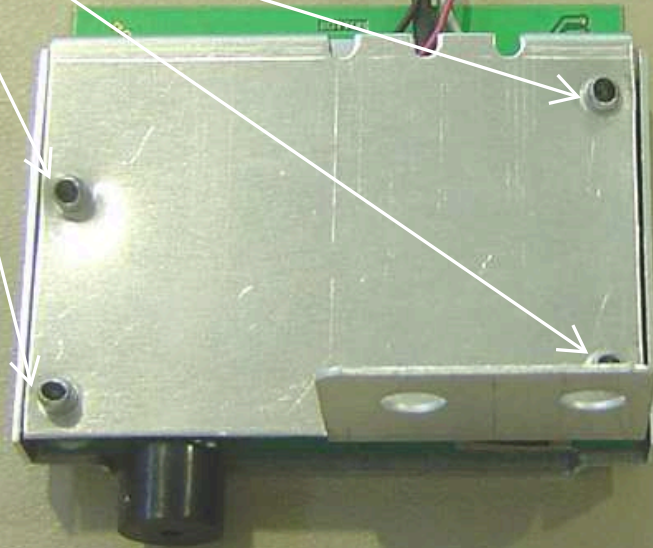

HOLD CABLES WITH
FLANGE P/N.-
73100002 (THIS IS
IMPORTANT TO AVOID
CABLES TOUCH LOAD
CELL)

RUNNING THE WIRE
UNDER THE GUIDE
LIKE SHOW IN
PICTURE

ASSEMBLY CABLE
GUIDE P/N.- 71210414
WITH SCREW P/N.-
19031015 AND
WASHER P/N.-
73050004

THREAD THE SCREW P/N.-
72012039 WITH WASHER P/
N.- 73050007 AND NUT P/N.-
72102009

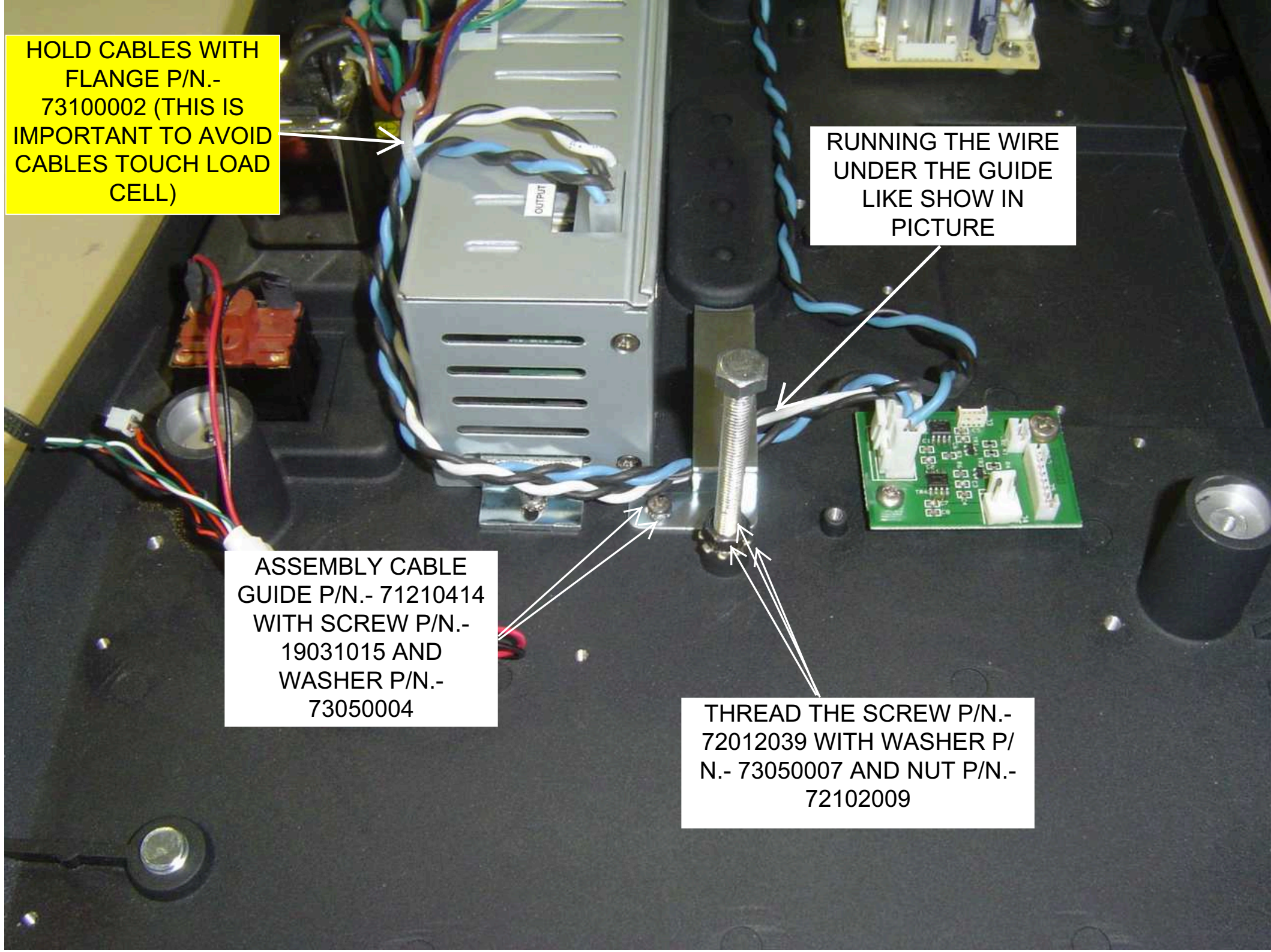

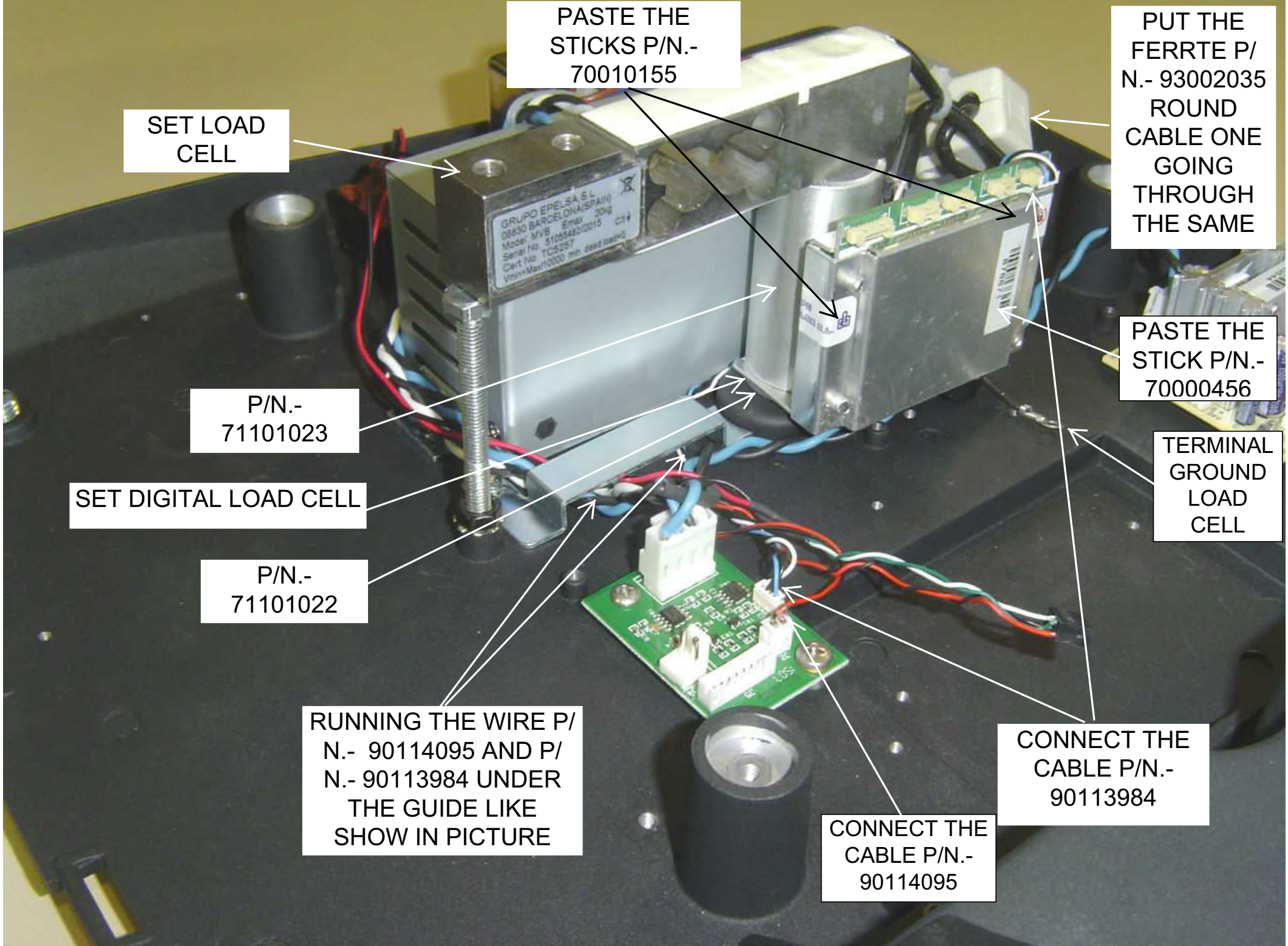

PASTE THE STICKS P/N.- 70010155

PUT THE FERRITE P/N.- 93002035 ROUND CABLE ONE GOING THROUGH THE SAME

SET LOAD CELL

PASTE THE STICK P/N.- 70000456

P/N.- 71101023

TERMINAL GROUND LOAD CELL

SET DIGITAL LOAD CELL

P/N.- 71101022

RUNNING THE WIRE P/N.- 90114095 AND P/N.- 90113984 UNDER THE GUIDE LIKE SHOW IN PICTURE

CONNECT THE CABLE P/N.- 90113984

CONNECT THE CABLE P/N.- 90114095

SCREWS P/N.-
72091042
TIGHTEN WITH A
REGULATED
TOOL TO A
TIGHTENING
TORQUE 11 Nm

P/N.- 73003001

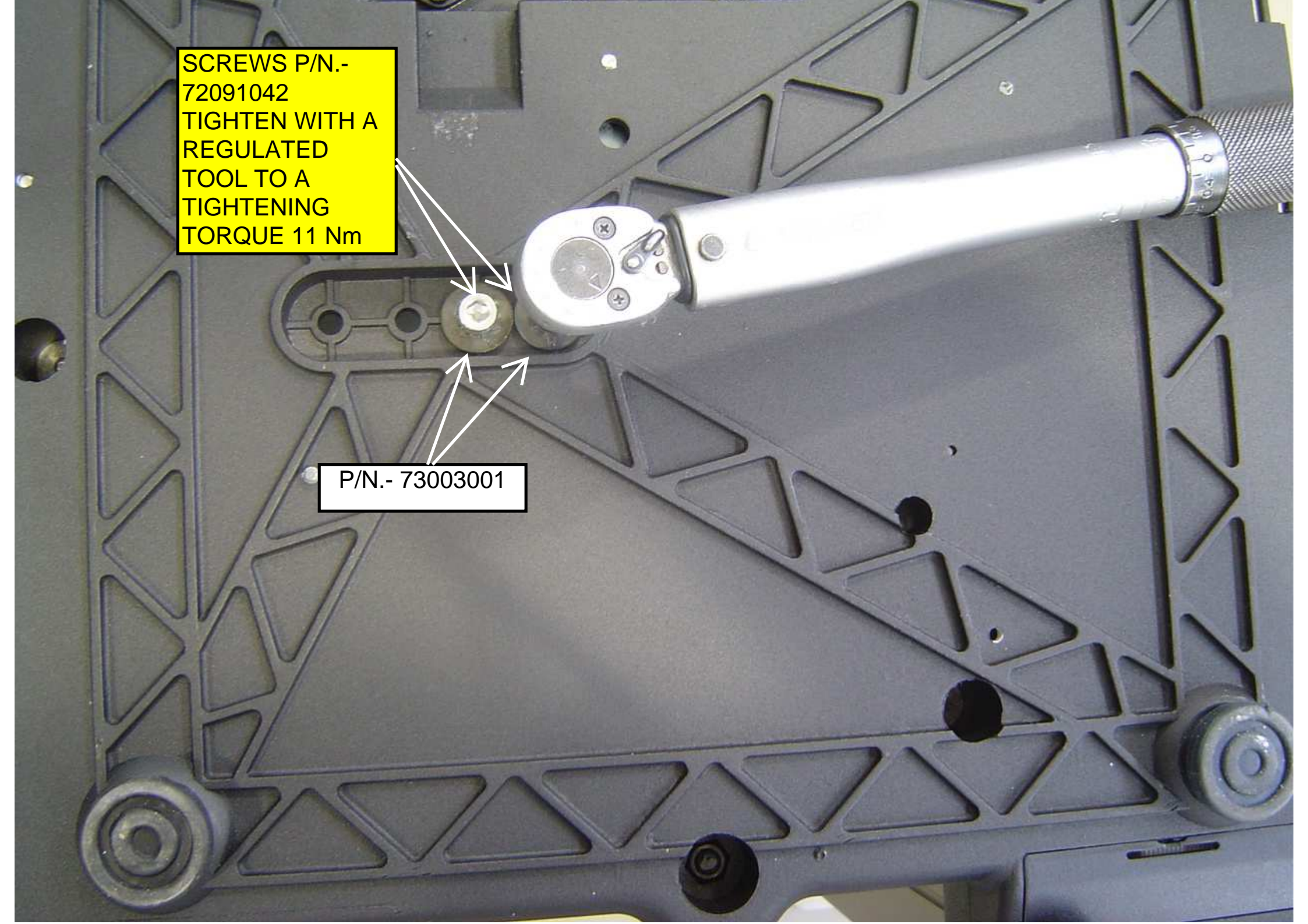

OTHER VIEW OF ASSEMBLY
THE FERRITE P/N.- 93002035
AND HOLD WITH A FLANGE
P/N.- 73100002

TERMINAL
GROUND
TERMINAL OF
LOAD CELL



PASTE THE
STICK P/N.-
70000456



GAUGE OF
0,60 mm

THE SCREW HAVE TO
GO UP UNTIL IT
TOUCHES THE GAUGE.
THEN, TO TIGHT THE
BOTTON NUT TILL IT
LEAVES STRONG FIT



4. ASSEMBLY PICO ITX BOARD AND CONNECTIONS BADGE

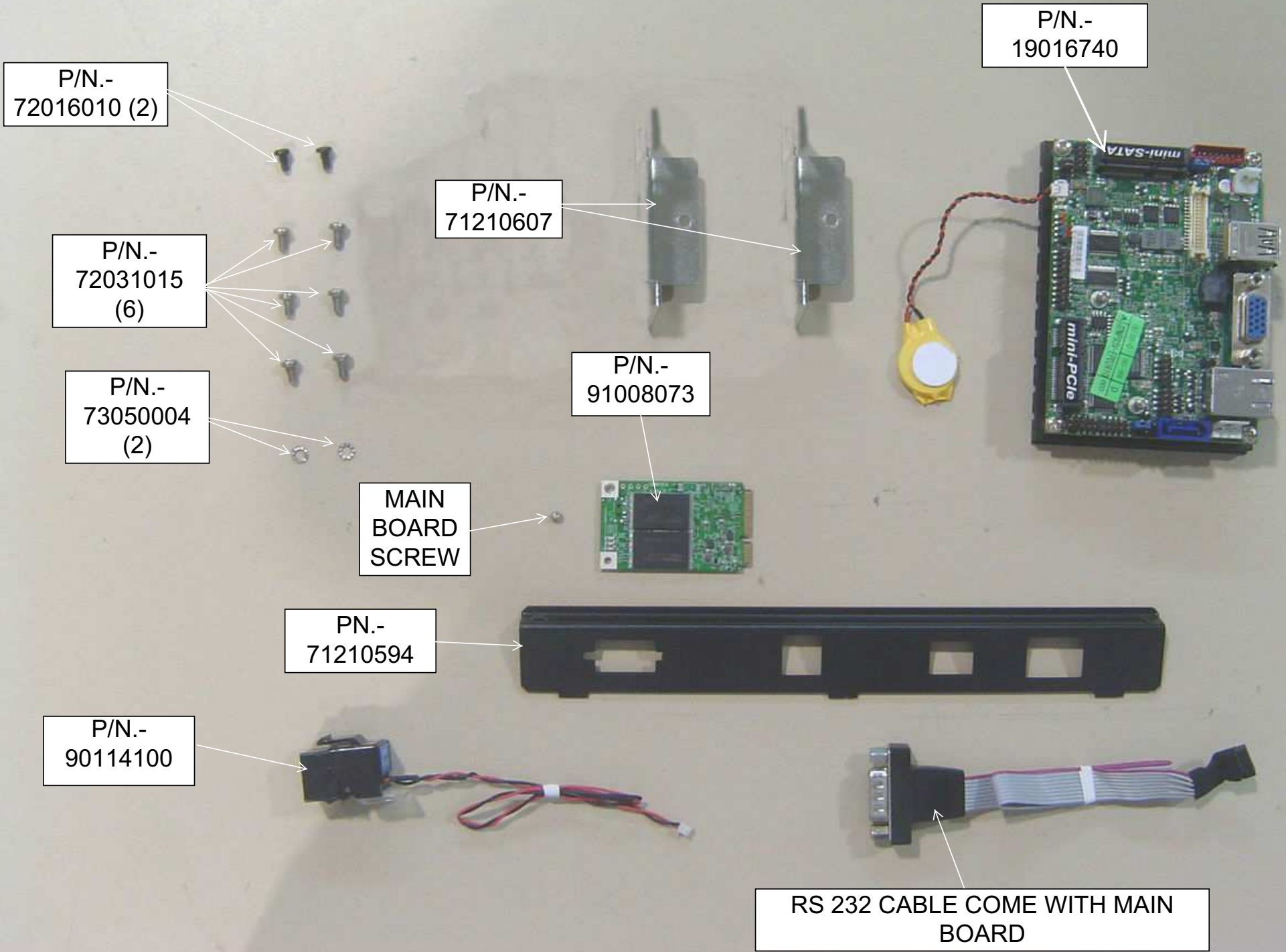

CONNECT FLASH
DISK MINI-SATA
AND HOLD WITH
THE SCREW

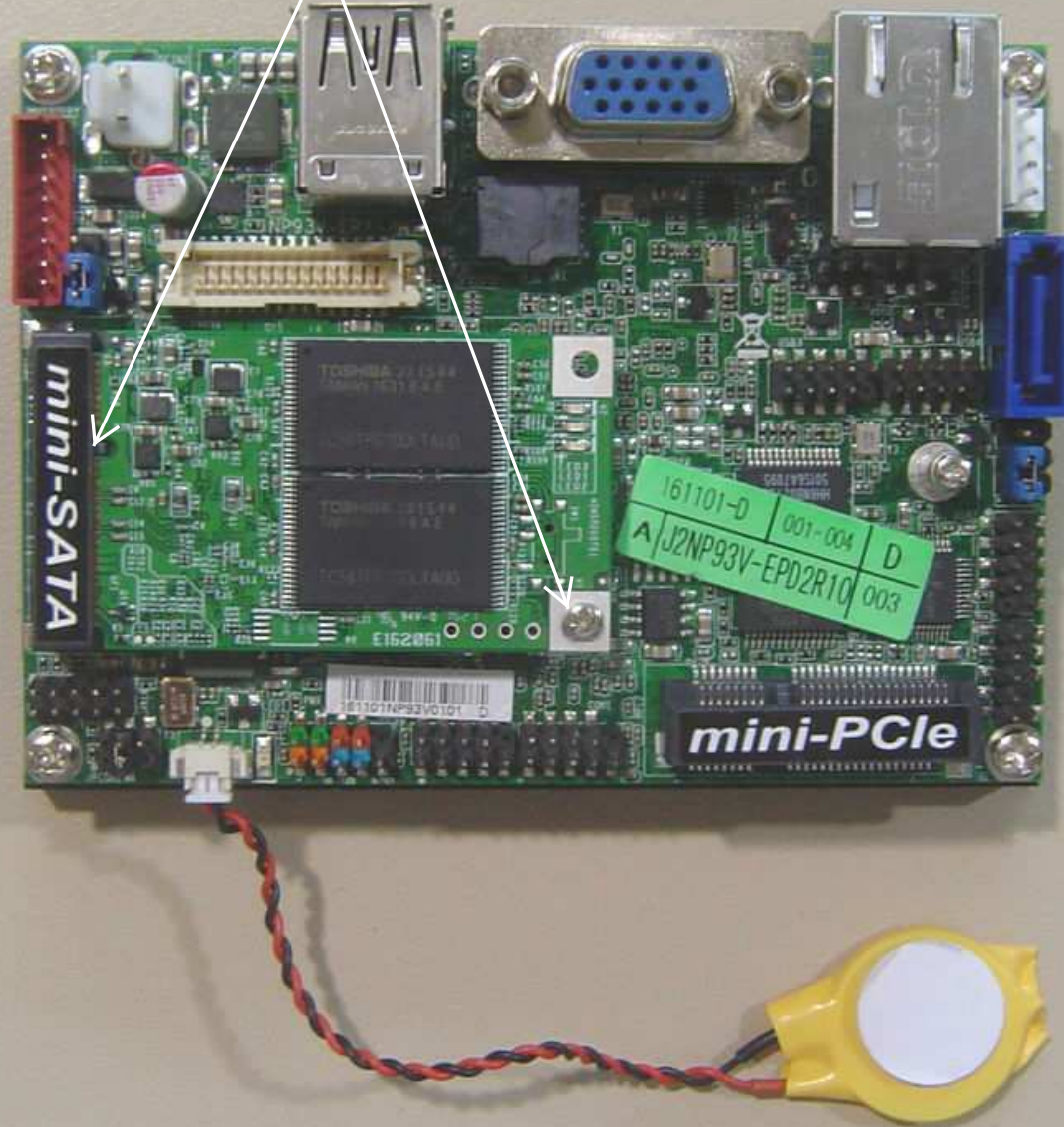

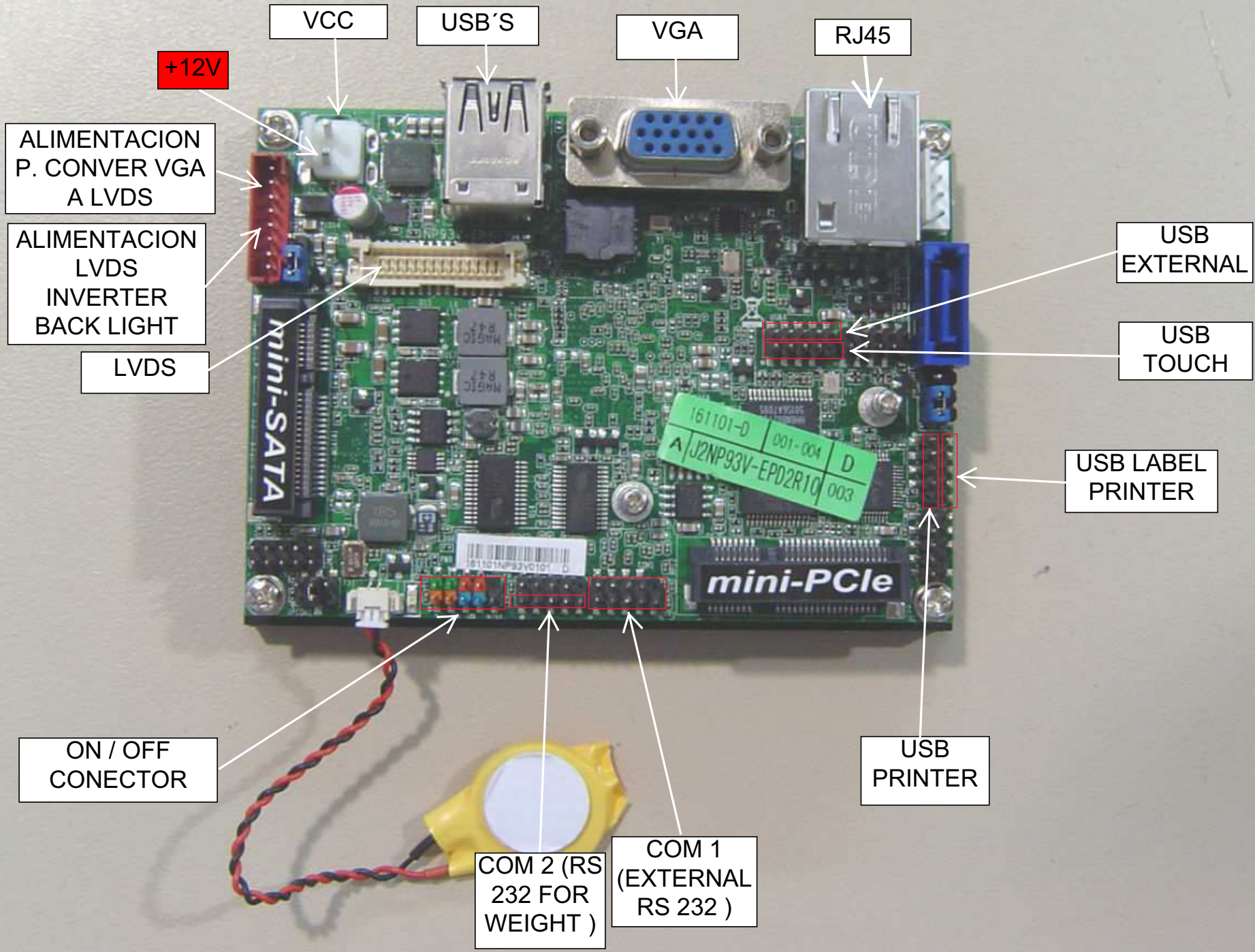

1-3 Layout Diagram

Internal Diagram-Front Side:

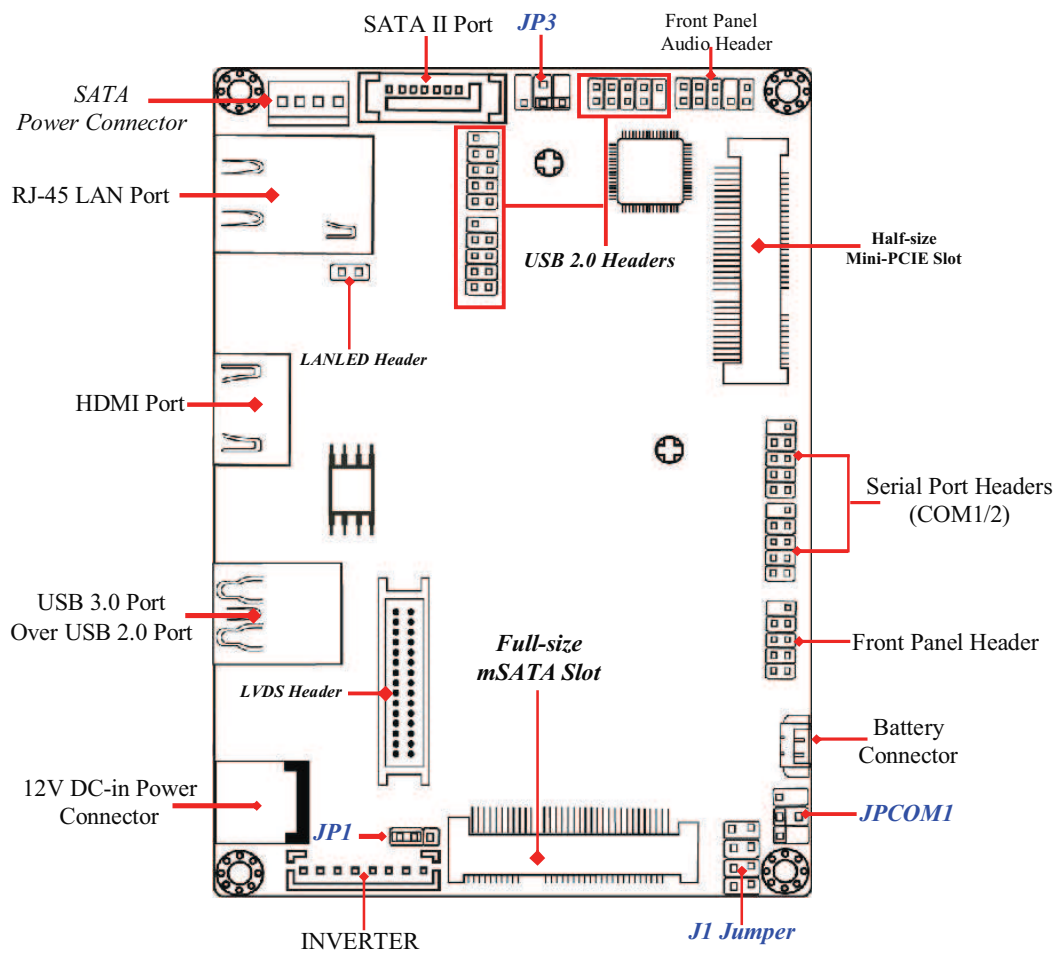

Internal Diagram-Back Side:

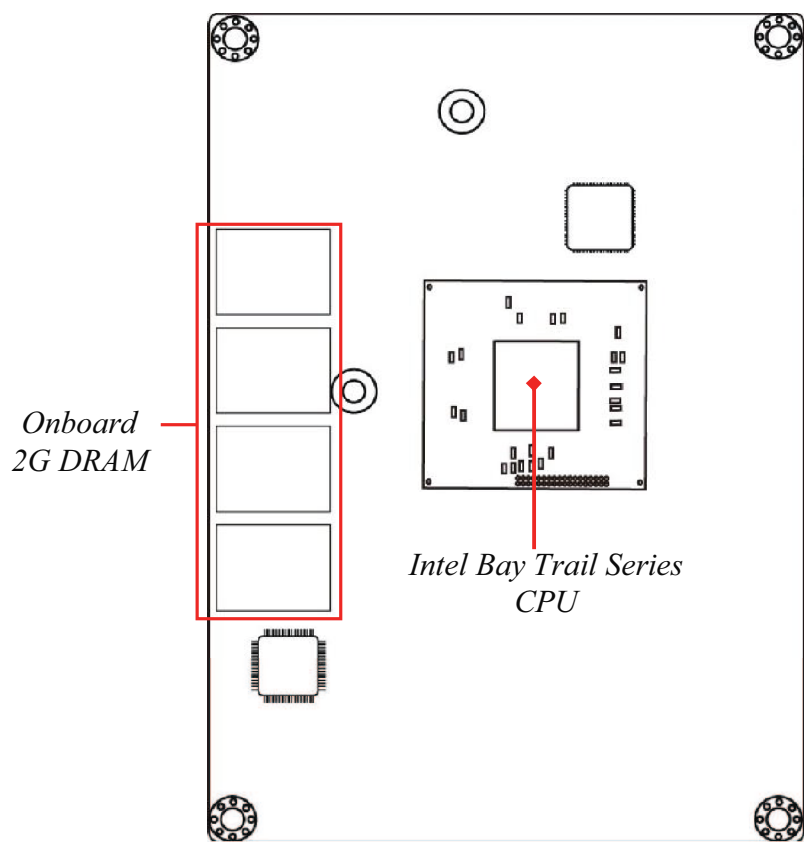

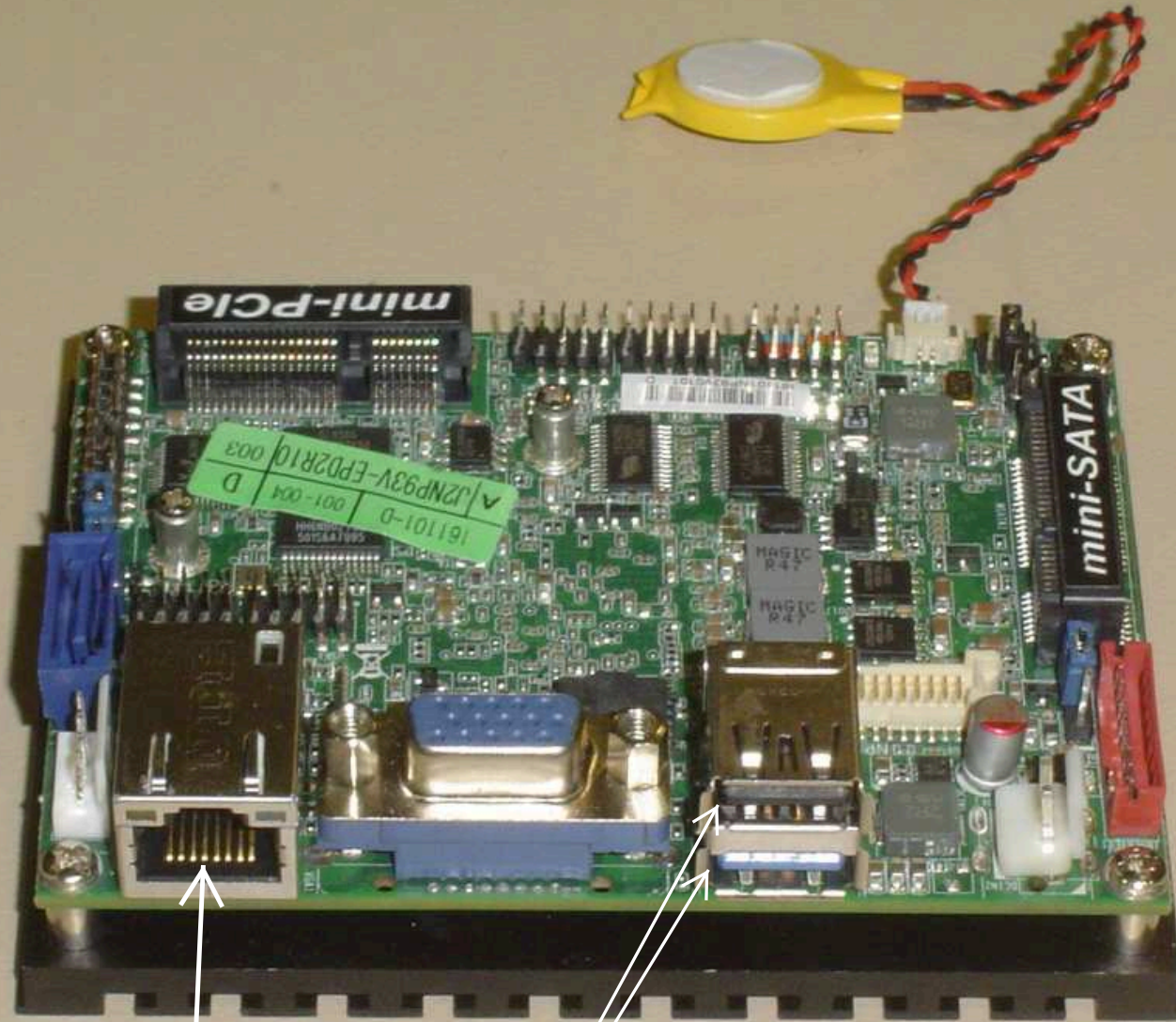

RJ45

USB'S



ASSEMBLY THE
CONNECTOR OF
CABLE P/N.-
90114100 AT THIS
POSICIÓN

ASSEMBLY THE CONNECTOR
OF RS232 CABLE AT THIS
POSITION AND HOLD WITH
THE TURRETS

BACK VIEW

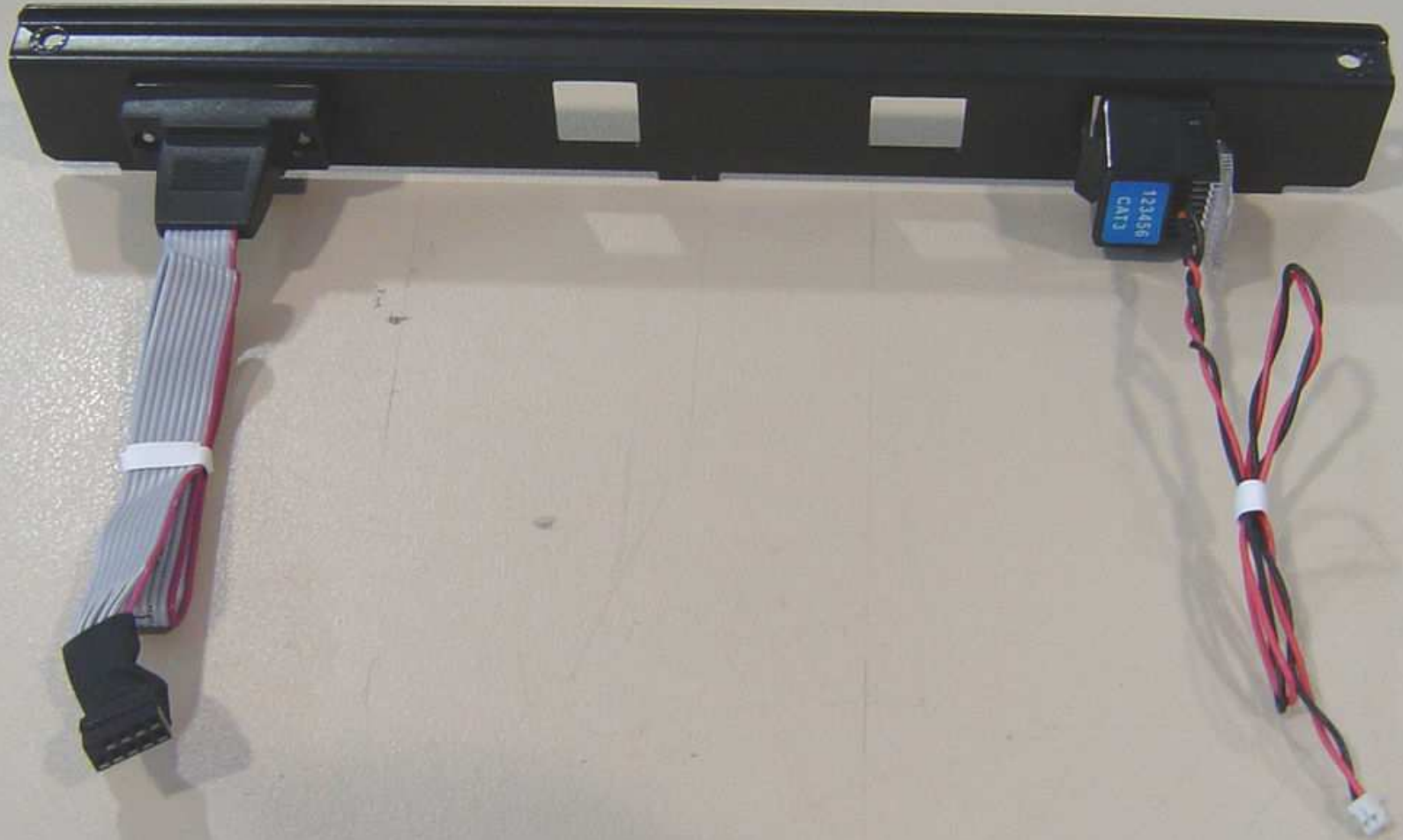

ASSEMBLY THE CONNECTIONS BADGE AND HOLD WITH 2 SCREWS P/N.- 72016010



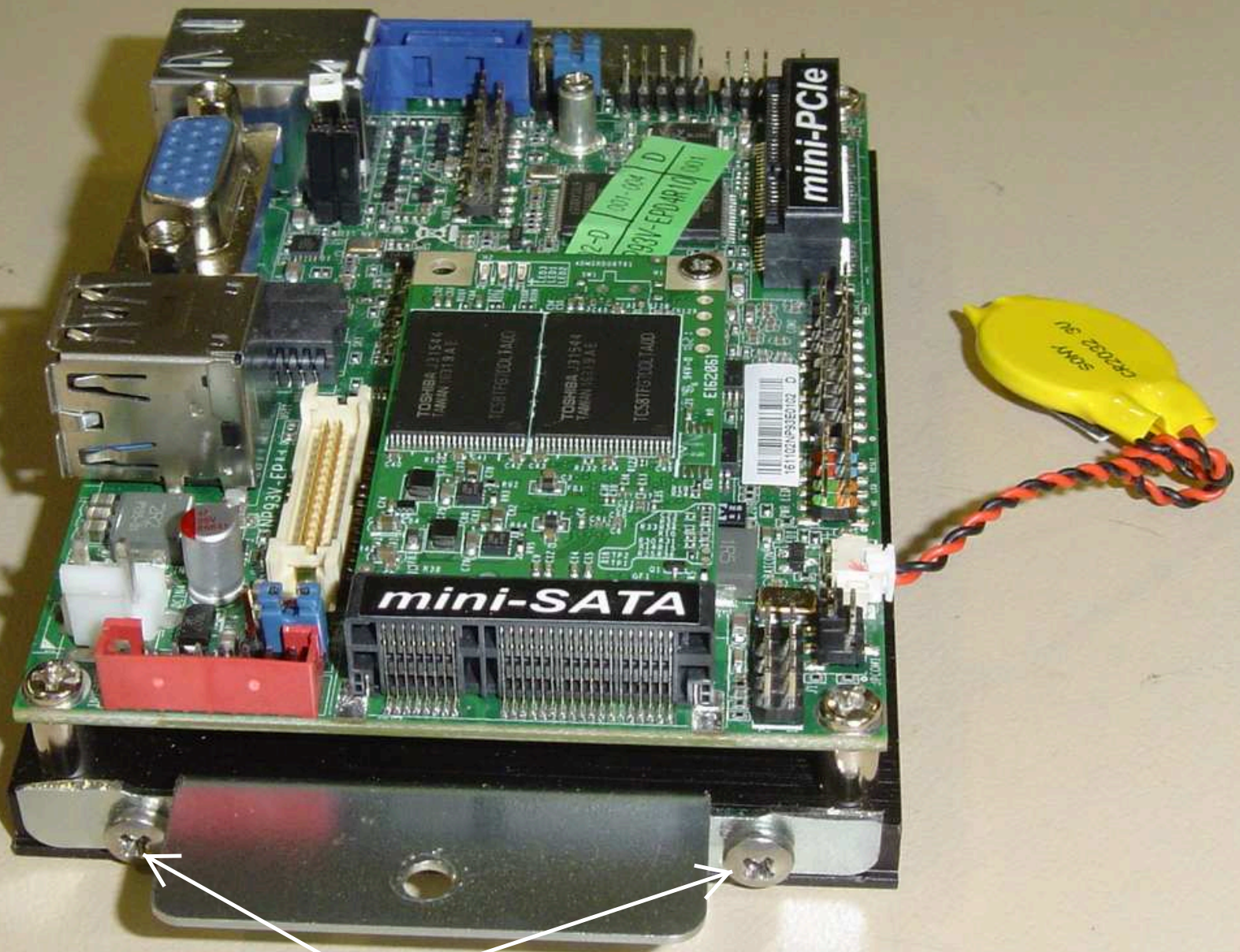

HOLD THE SUPPORT PN.- 7121067 TO THE MAIN BOARD WITH SCREWS P/N.- 72031015

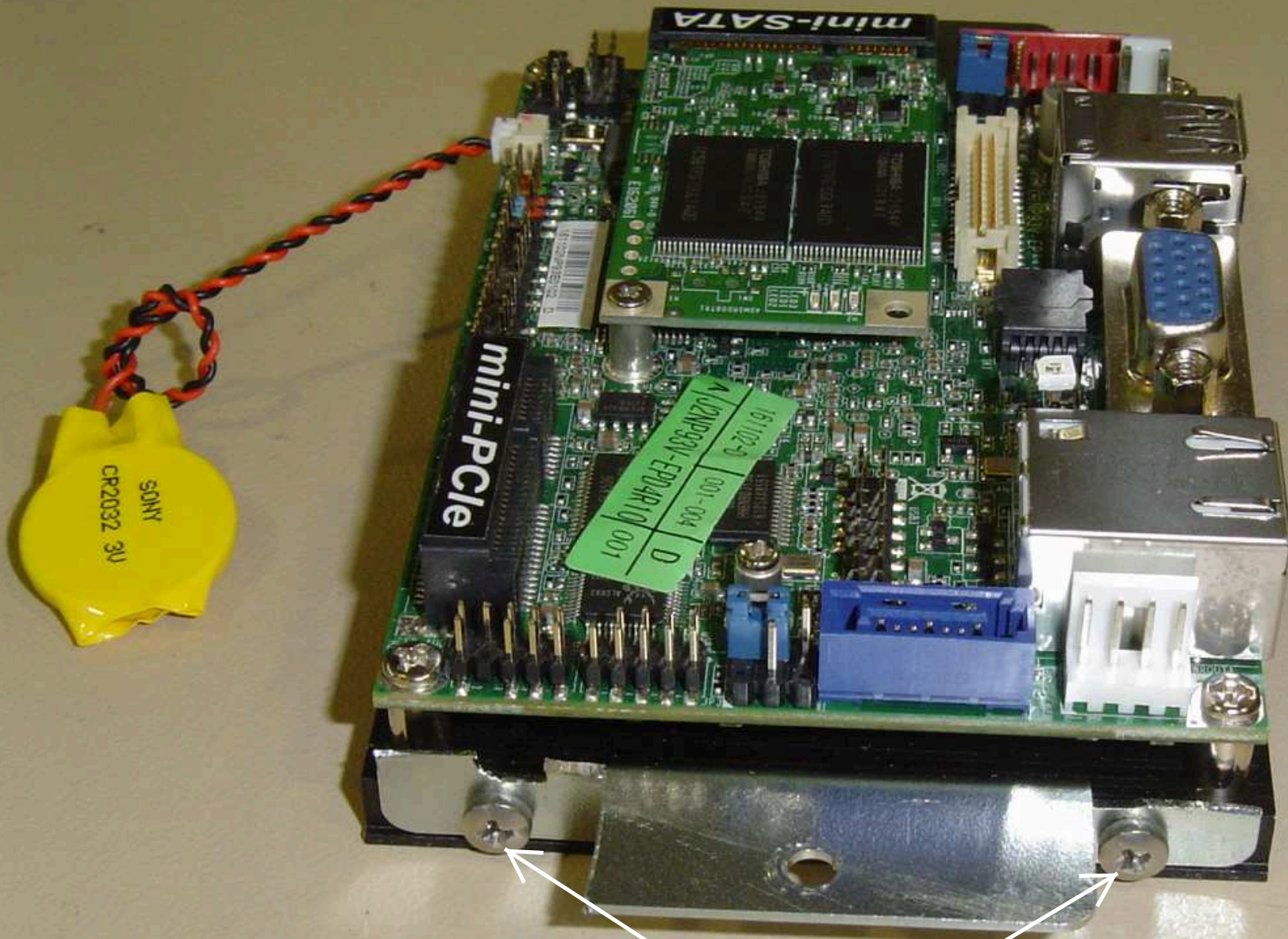

HOLD THE SUPPORT PN.- 71210607 TO THE MAIN BOARD WITH SCREWS P/N.- 72031015

CONNECT THE
CABLE P/N.-
90114100

CONNECT THE CABLE P/N.-
90114095 (SEE NEXT
PICTURE)

CONNECT RS 232
CABLE. (SEE NEXT
PICTURE)

PASTE THE
BATTERY

HOLD WITH
FLANGE

HOLD THE SUPPORT WITH 2
SCREWS P/N.- 72031015 AND 2
WHASERS P/N.- 73050004

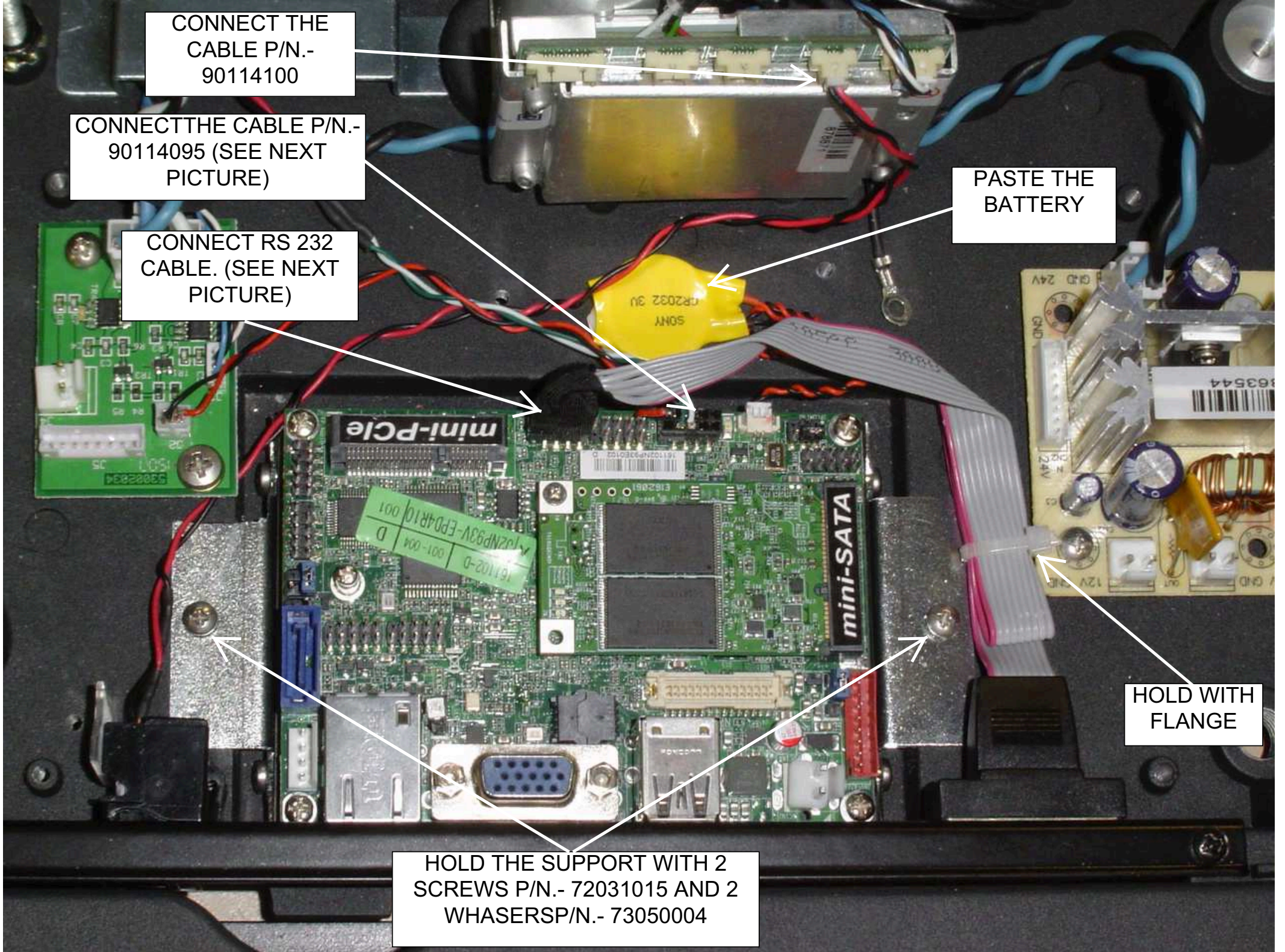

08830 BARCELONA (SPAIN)
Model: MVB Emax 20kg
Serial No: 51055482/2015
Cert No: TC5257
Vmin=Max/10000 min dead load=0

CONNECT THE
CABLE P/N.-
90114100



CONNECT RS 232
CABLE. RED LINE TO
RIGHT



CONNECT THE CABLE P/N.-
90114095. WITHOUT PINES
TO RIGHT

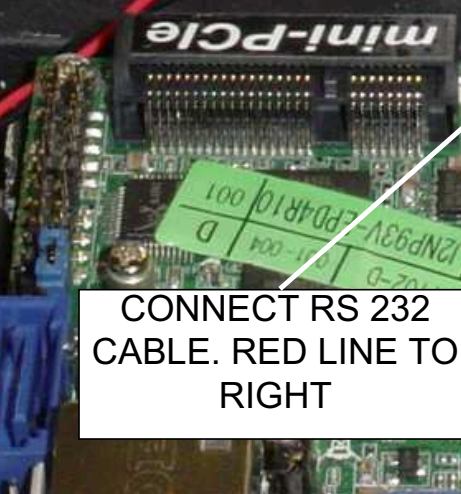
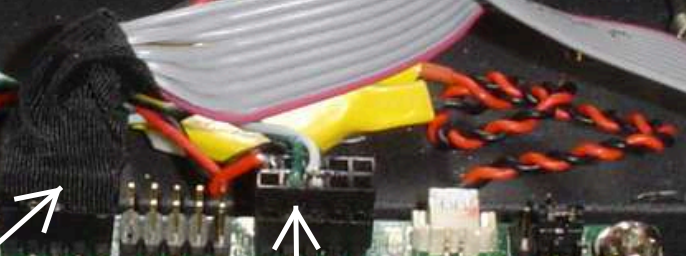

5.- CONNECT CABLES (COMPONENTS)

P/N.-
90114089



P/N.-
90114098



P/N.-
90114097

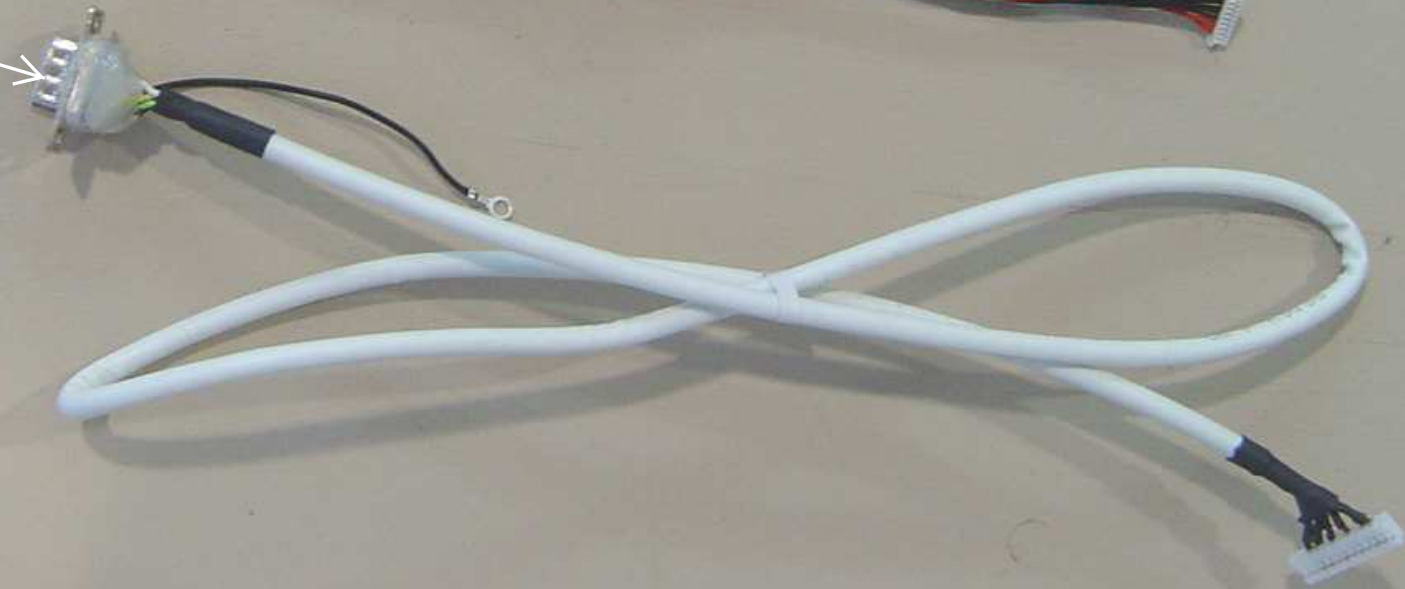

5.- CONNECT CABLES (COMPONENTS)

P/N.-
90113910



P/N.-
90114054



P/N.-
90114055



P/N.-
90114090

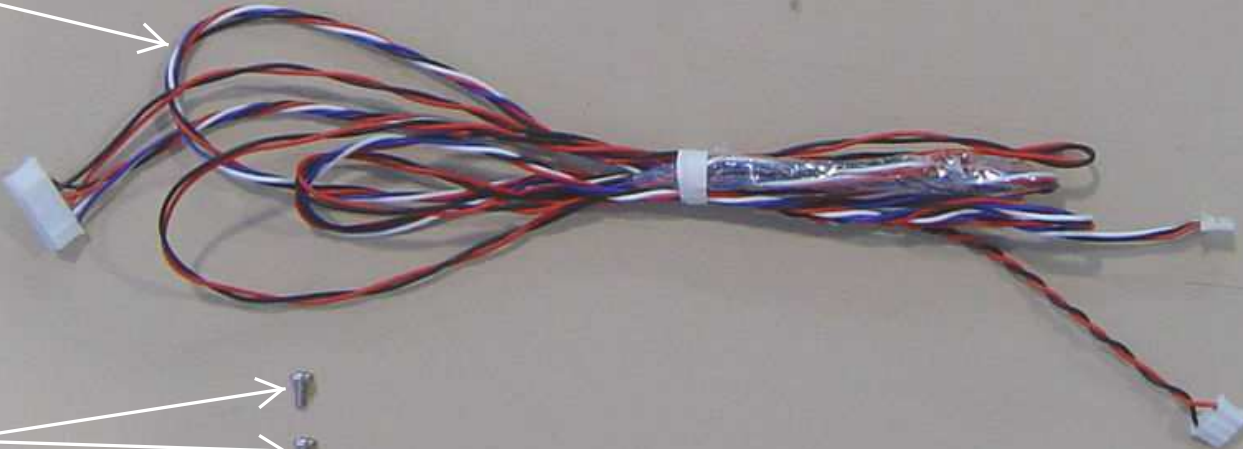

P/N.-
72031015
(2)



5.- CONNECT CABLES (COMPONENTS)

P/N.-
90113988



P/N.-
90114091



P/N.-
90114099



P/N.-
90114092



CONNECT
CABLE P/N.-
90113910

CONNECT
CABLE P/N.-
90114090

CONNECT
CABLE P/N.-
90114089

CONNECT
CABLE P/N.-
90114054
(SEE NEXT
PICTURE)

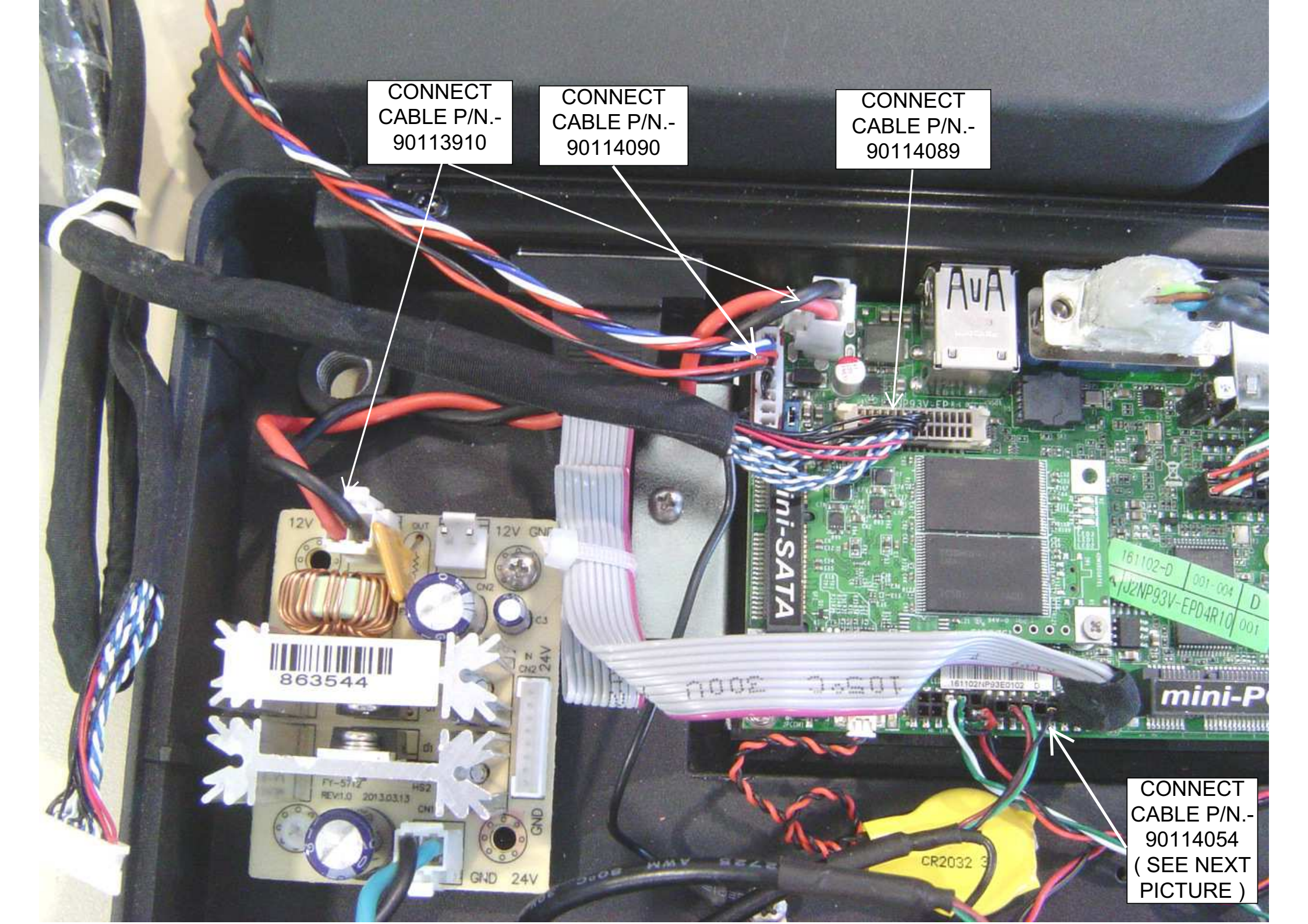

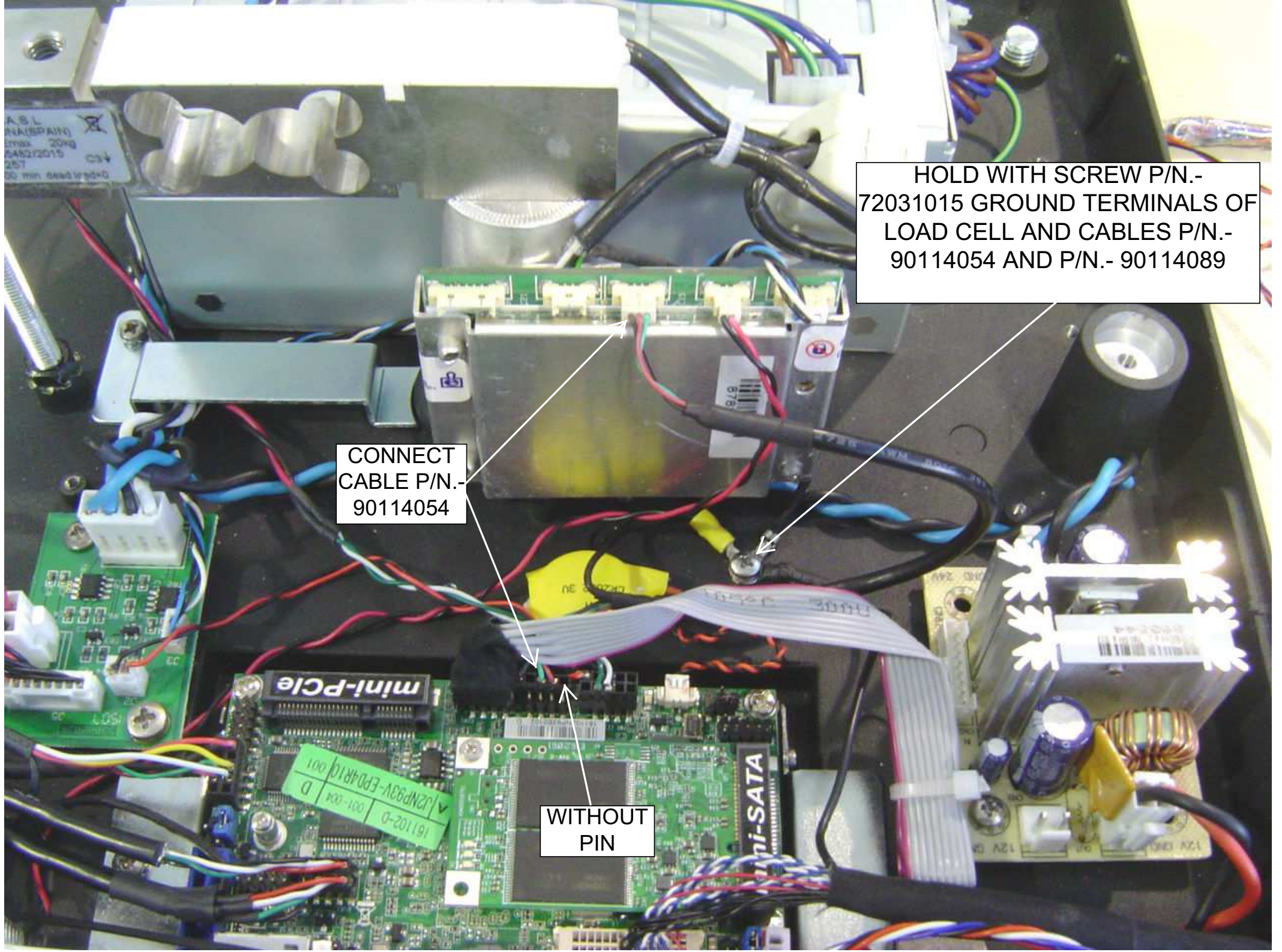

HOLD WITH SCREW P/N.-
72031015 GROUND TERMINALS OF
LOAD CELL AND CABLES P/N.-
90114054 AND P/N.- 90114089

CONNECT
CABLE P/N.-
90114054

WITHOUT
PIN

CONNECT
CABLE P/N.-
90114097

HOLD WITH SCREW P/N.-
72031015 GROUND TERMINALS OF
CABLES P/N.- 90114091, P/N.-
90114097 AND P/N.- 90114099

TERMINALS
WITHOUT
PINES

CONNECT
CABLE P/N.-
90114091

CONNECT
CABLE P/N.-
90114092

CONNECT
CABLE P/N.-
90114098

CONNECT
CABLE P/N.-
90114099

CONNECT
CABLE P/N.-
90114055

CONNECT
CABLE P/N.-
90113988

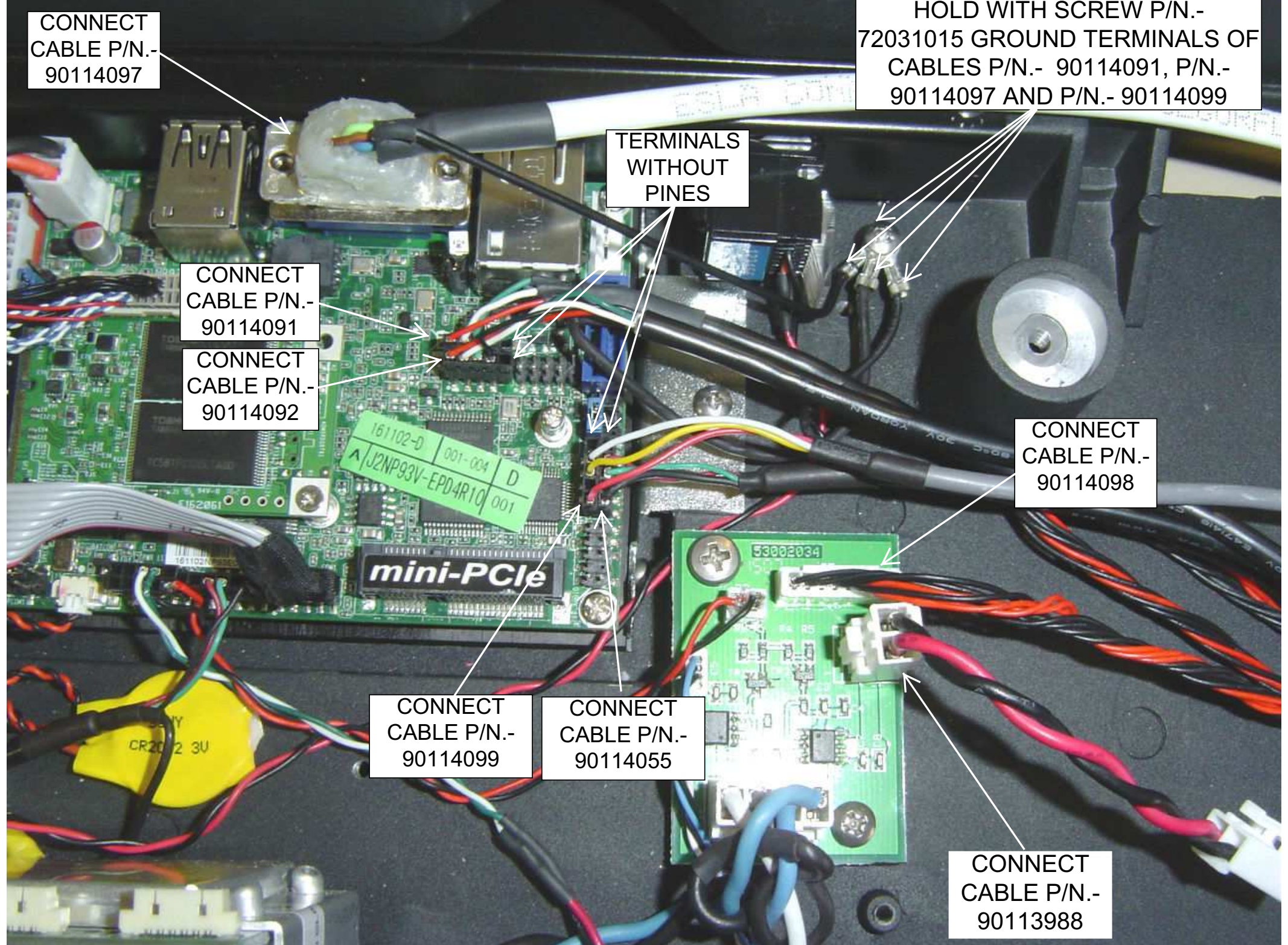

OVERVIEW

PASTE THE
STICKERS P/N.-
70000456

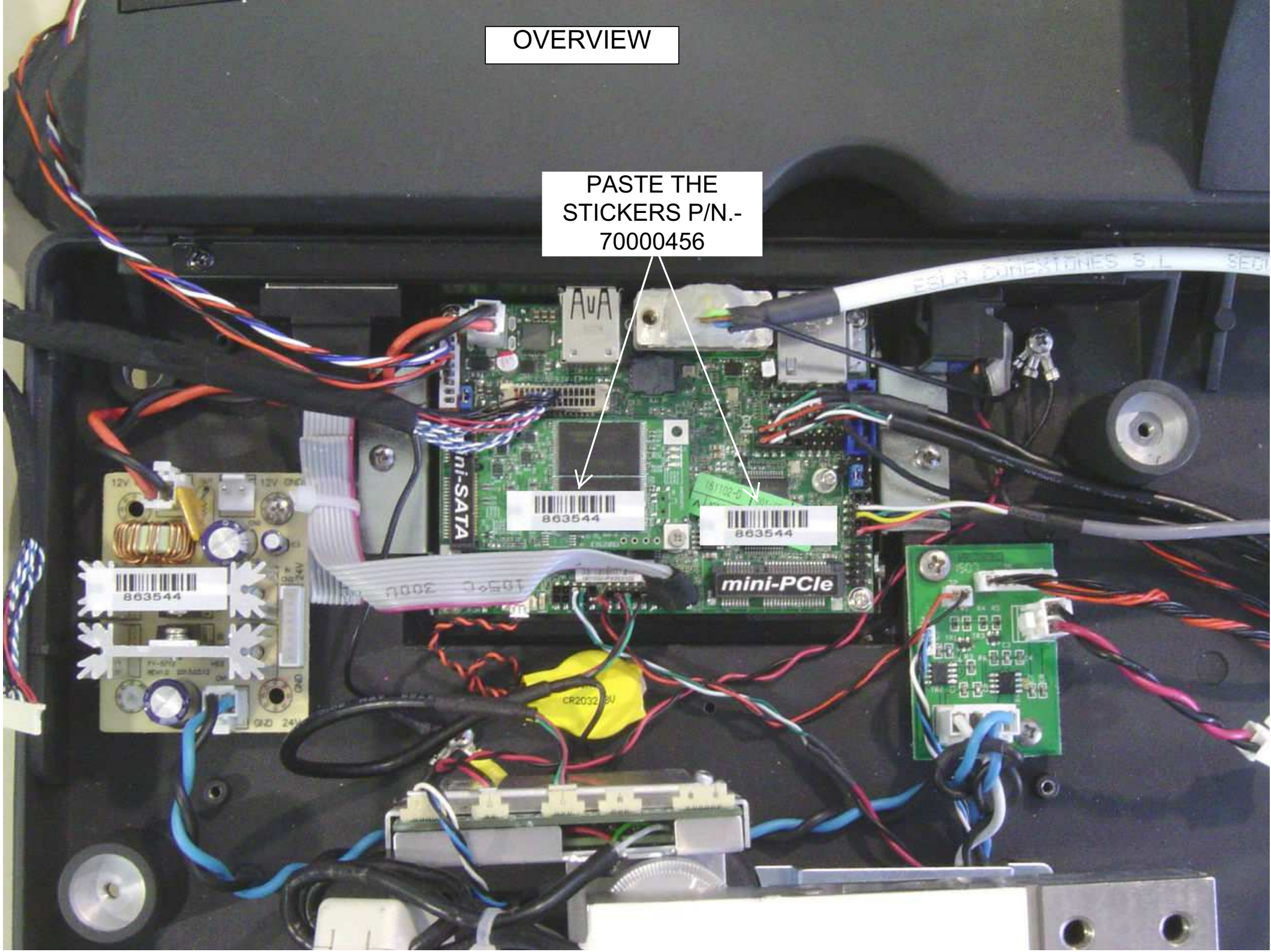

JOIN THE CABLES P/N.-
90114098 AND P/N.-
90114099, WITH FLANGE
P/N.- 73100002,
INDEPENDENTLY

HOLD THE
CABLES WITH
FLANGES P/N.-
73100002.

NOT TIGHTEN
FOR THE
CABLES CAN
MOVE

6.- ASSEMBLY SET LABEL PRINTER (COMPONENTS)

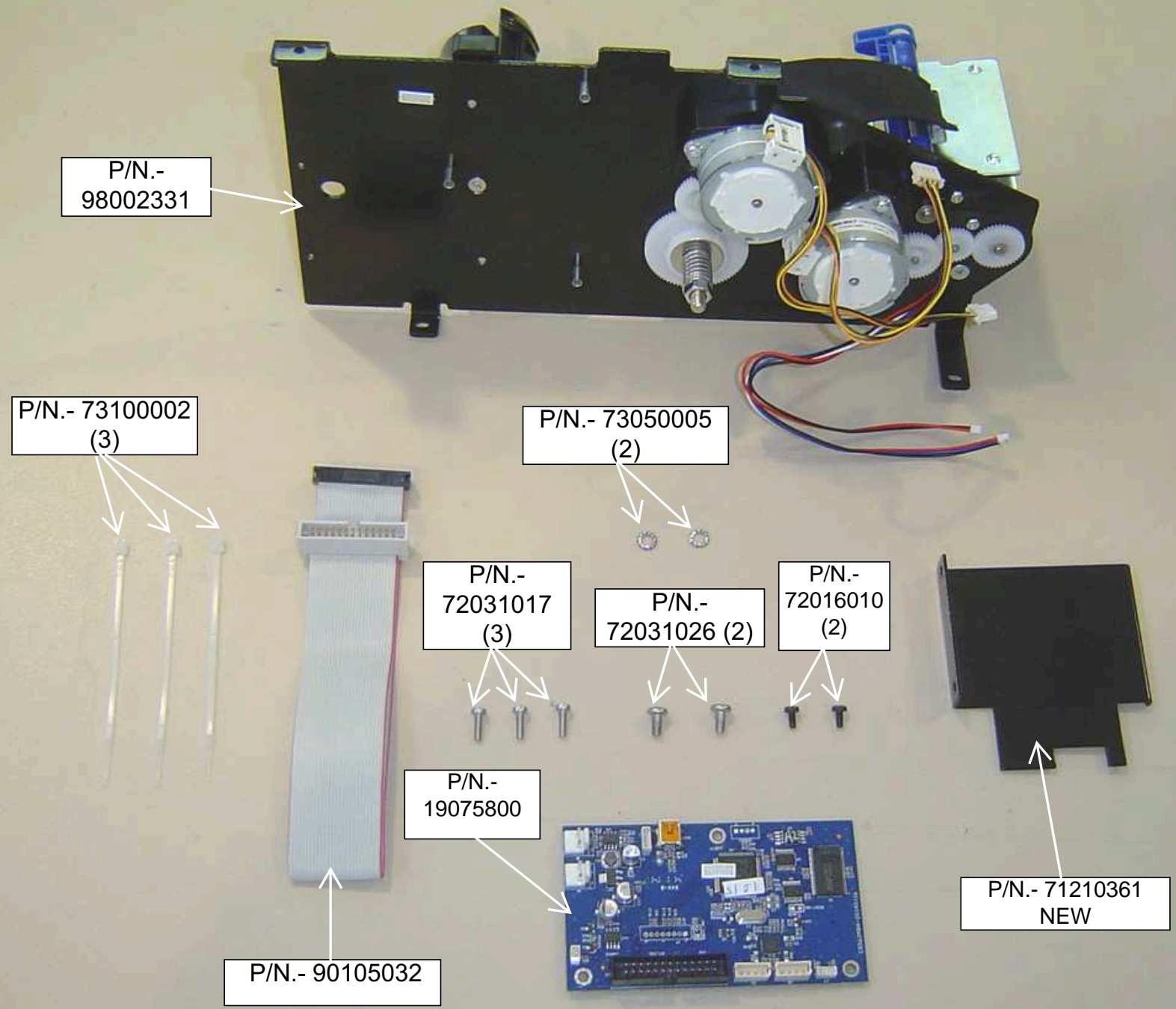

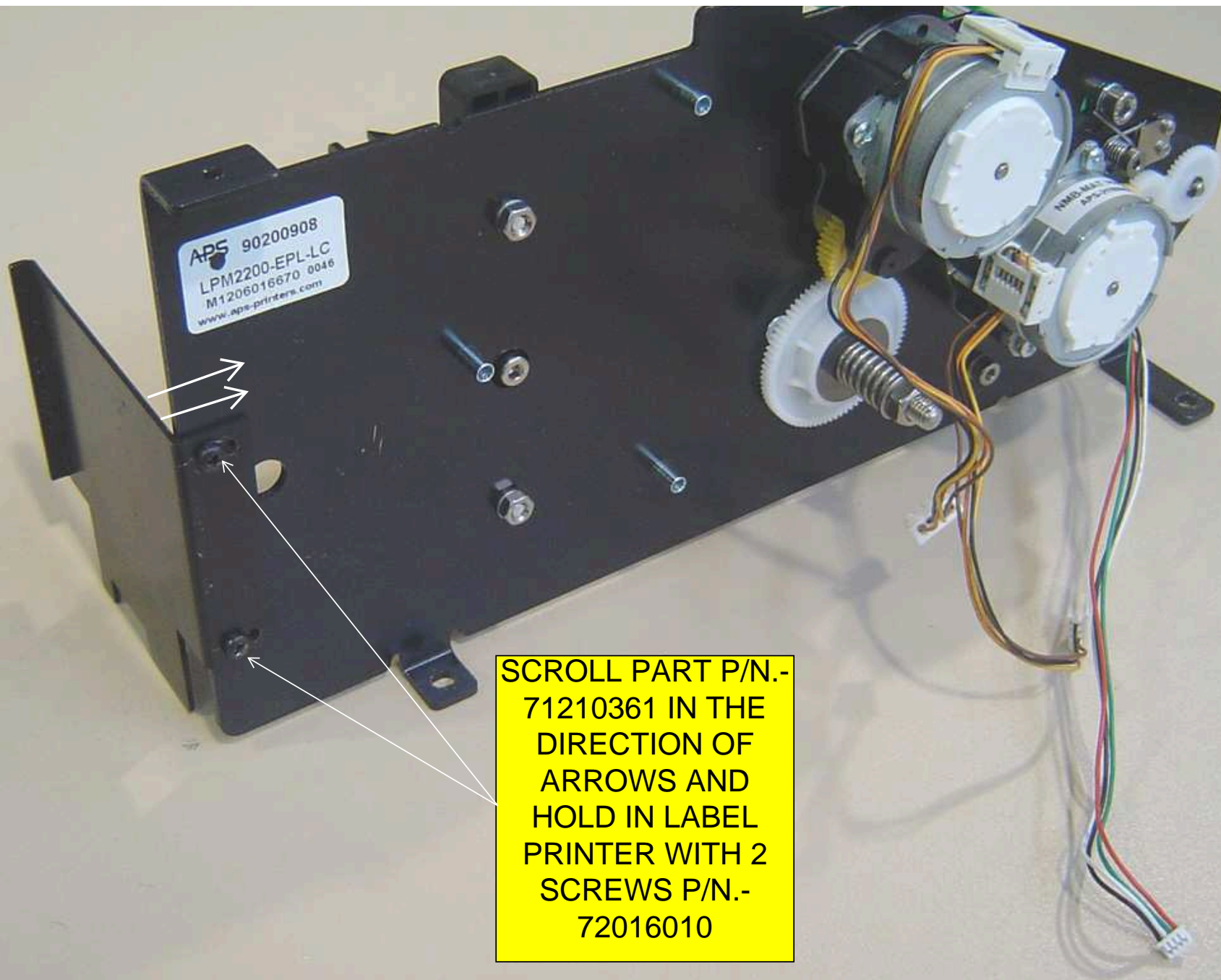

APS 90200908
LPM2200-EPL-LC
M1206016670 0046
www.aps-printers.com

SCROLL PART P/N.-
71210361 IN THE
DIRECTION OF
ARROWS AND
HOLD IN LABEL
PRINTER WITH 2
SCREWS P/N.-
72016010

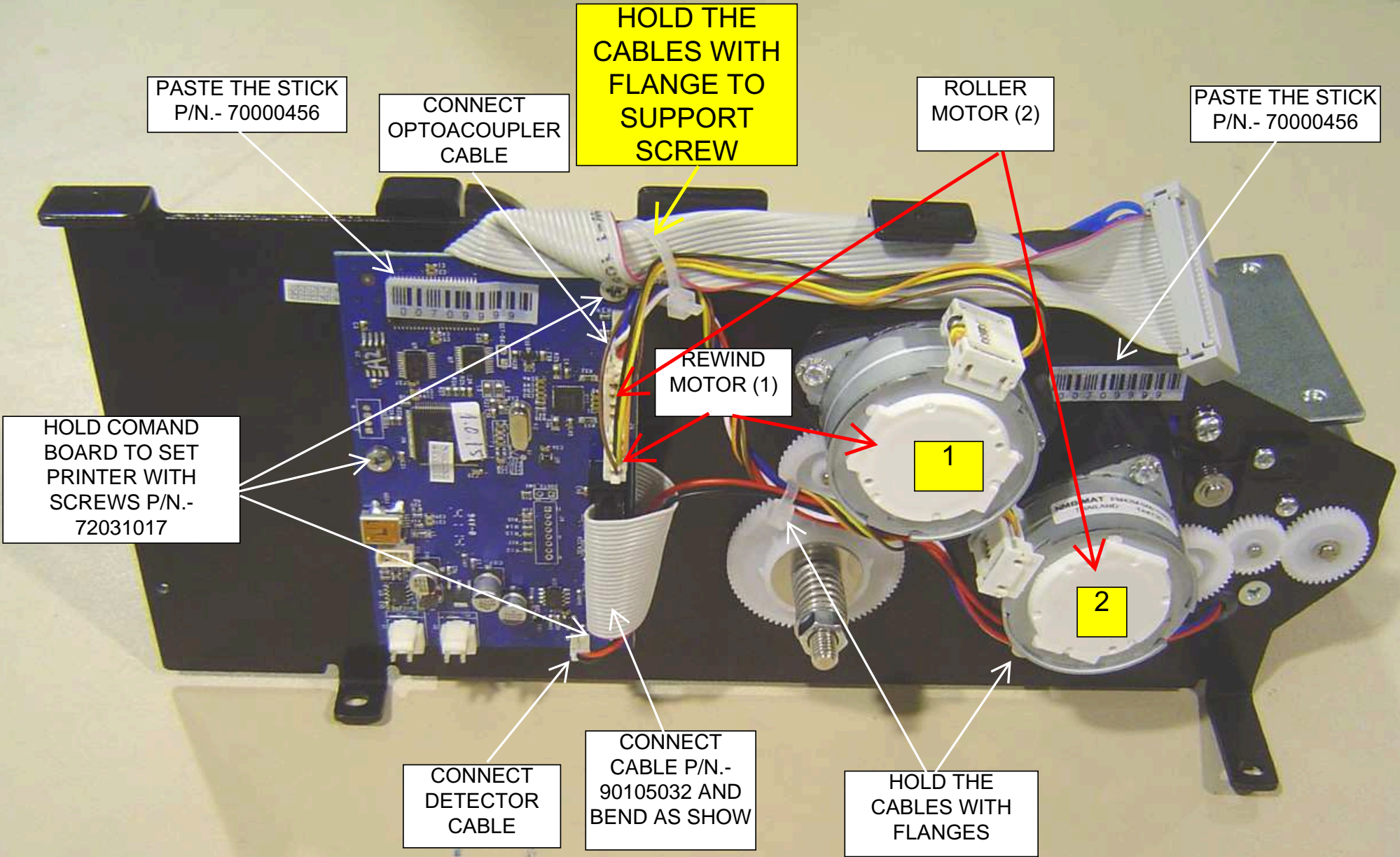

HOLD THE CABLES WITH FLANGE TO SUPPORT SCREW

PASTE THE STICK P/N.- 70000456

CONNECT OPTOACOUPLER CABLE

ROLLER MOTOR (2)

PASTE THE STICK P/N.- 70000456

REWIND MOTOR (1)

1

2

HOLD COMAND BOARD TO SET PRINTER WITH SCREWS P/N.- 72031017

CONNECT DETECTOR CABLE

CONNECT CABLE P/N.- 90105032 AND BEND AS SHOW

HOLD THE CABLES WITH FLANGES

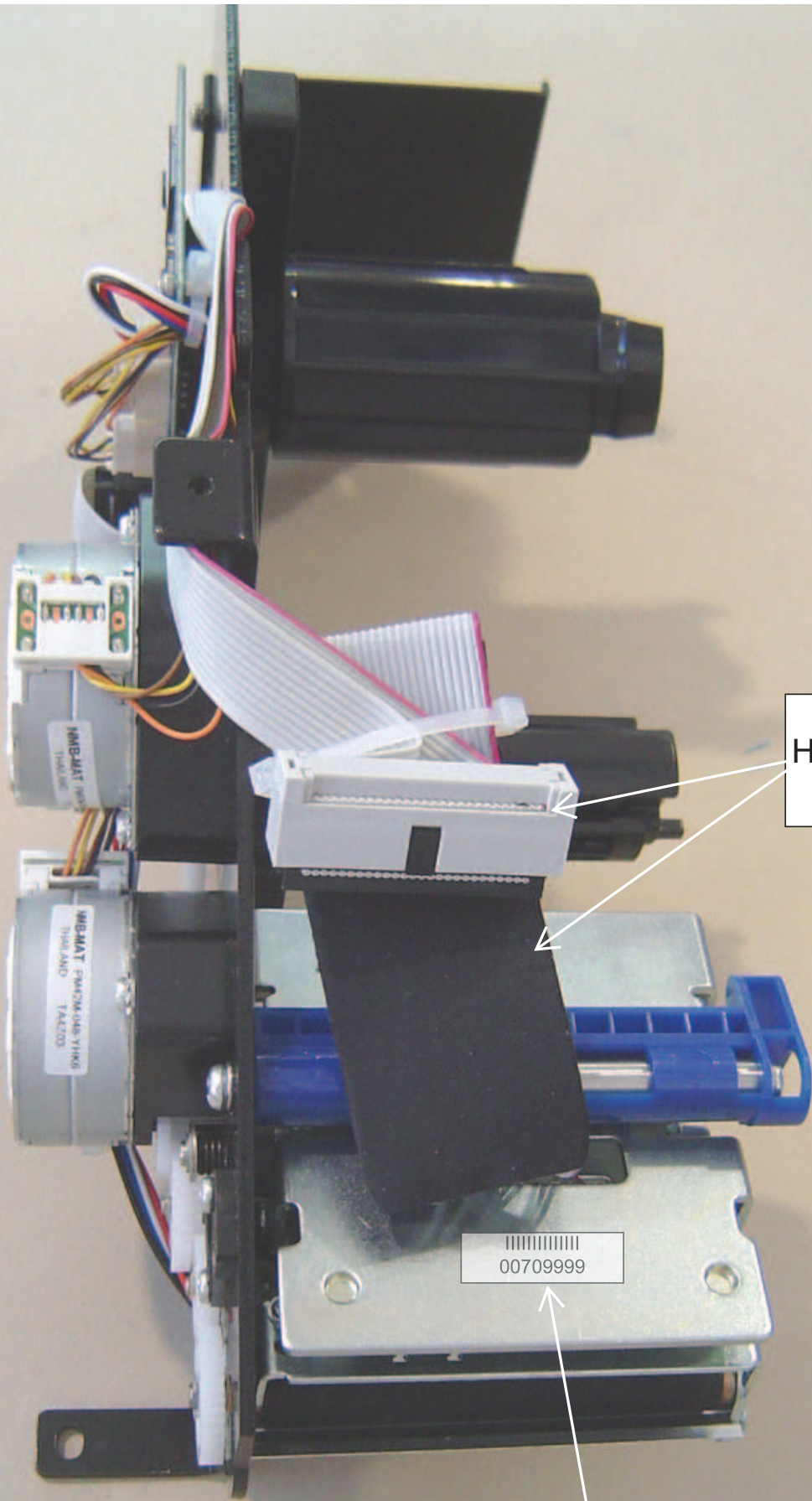

CONNECT
HEAD PRINTER
CABLE

00709999

PASTE THE
STICK P/N.-
7000456 ON
HEAD PRINTER

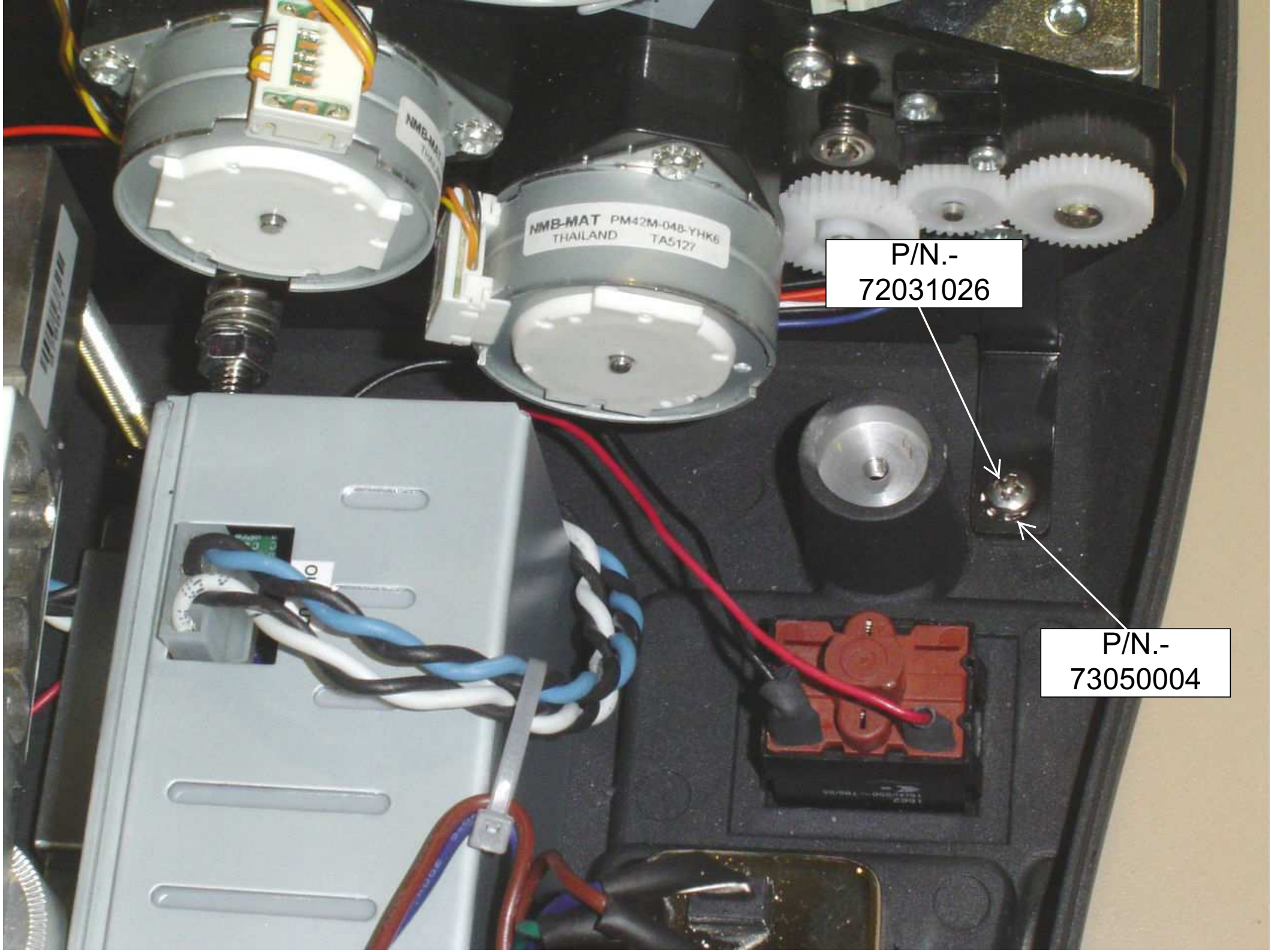



P/N.-
72031026

P/N.-
73050004

P/N.-
72031026

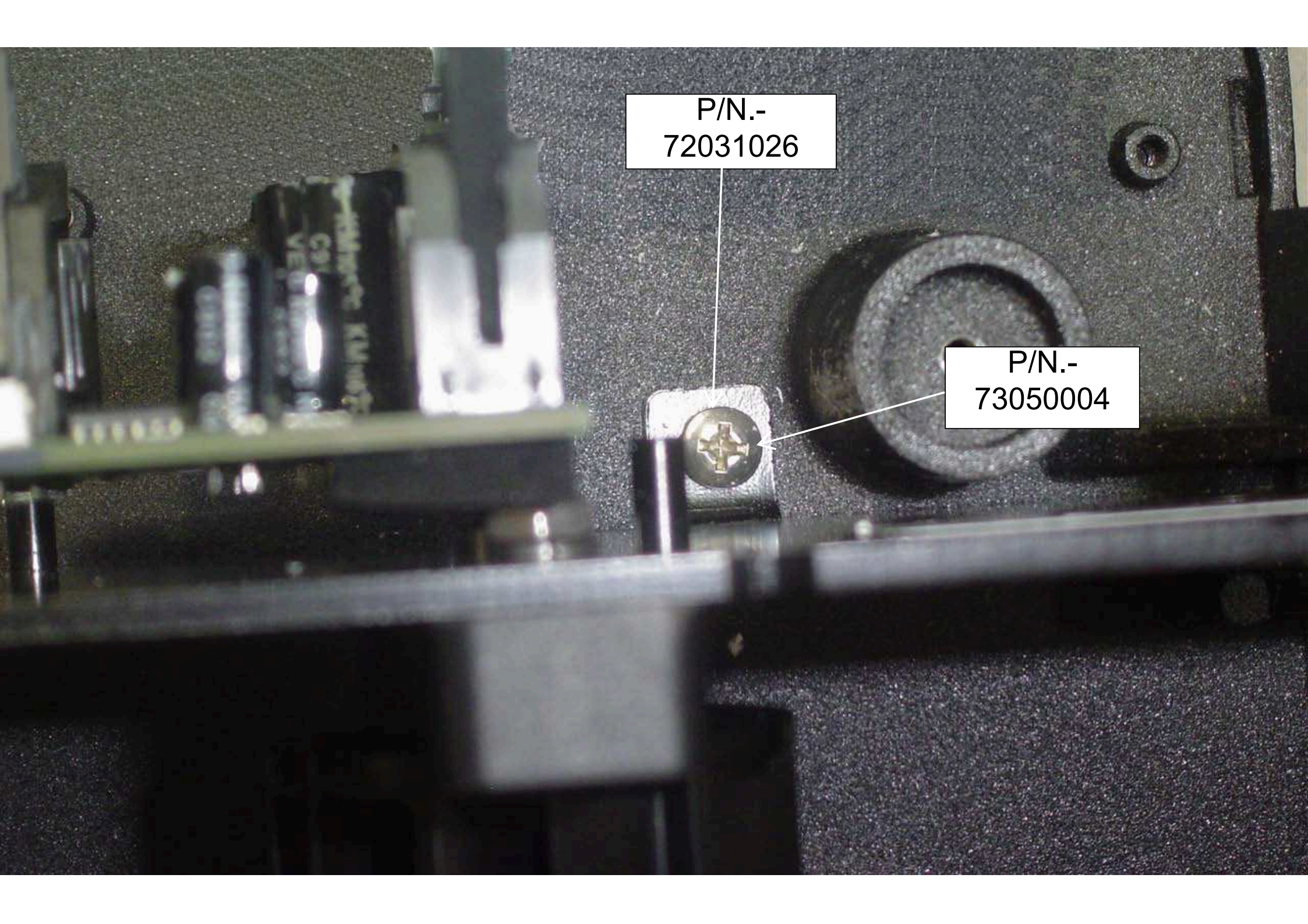
P/N.-
73050004





TO CONNECT 5
WAYS CONECTOR
CABLE P/N.-
90114055 TO J3 IN
LABEL PRINTER
COMAND BOARD

The image shows the internal components of a label printer. A blue printed circuit board (PCB) is the central focus, populated with various electronic components including integrated circuits, capacitors, and connectors. A white ribbon cable is connected to a multi-pin connector on the right side of the board. Below the blue board, a green PCB is visible, featuring a 'mini-PCIe' slot. Numerous colored wires (red, black, blue, yellow, green) are routed across the printer's chassis, some secured with white zip ties. A white label with a barcode and the number '878871' is affixed to the blue board. Another white label with a barcode and the number '07242A-B-524033' is located to the left. A white text box with an arrow points to a specific connector on the blue board, and another white text box with an arrow points to a different connector on the same board.

TO CONNECT CABLE
P/N.- 90113988 TO J4
IN COMAND BOARD

7.- ASSEMBLY DOOR AND COLUMN (COMPONENTS)

P/N.-
71004438



P/N.-
72090066
(3)



P/N.-
79202004



7.- ASSEMBLY DOOR AND COLUMN (COMPONENTS)

P/N.- 70010321

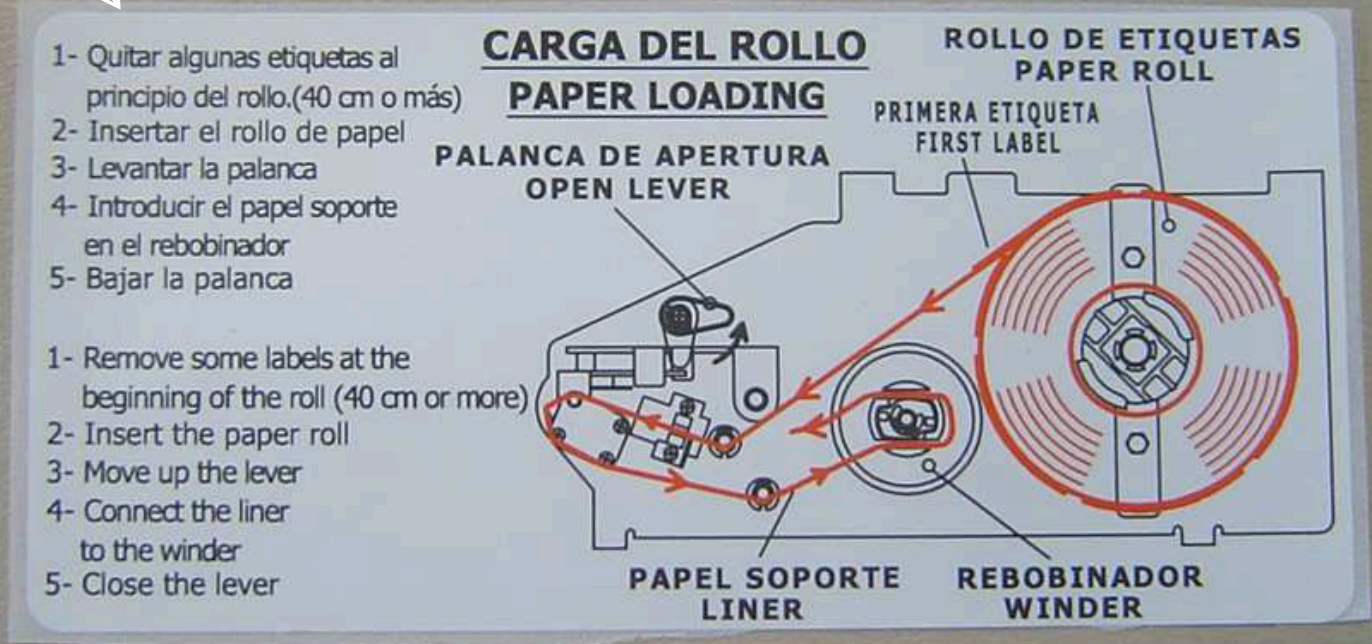

7.- ASSEMBLY DOOR AND COLUMN (COMPONENTS)

P/N.-
71002310



P/N.-
72062035
(2)



P/N.-
71000080



P/N.-
71001819

FIT THE SIDE CLOSING DOOR
INSERT THE OUTSIDE
TOWARD THE INSIDE

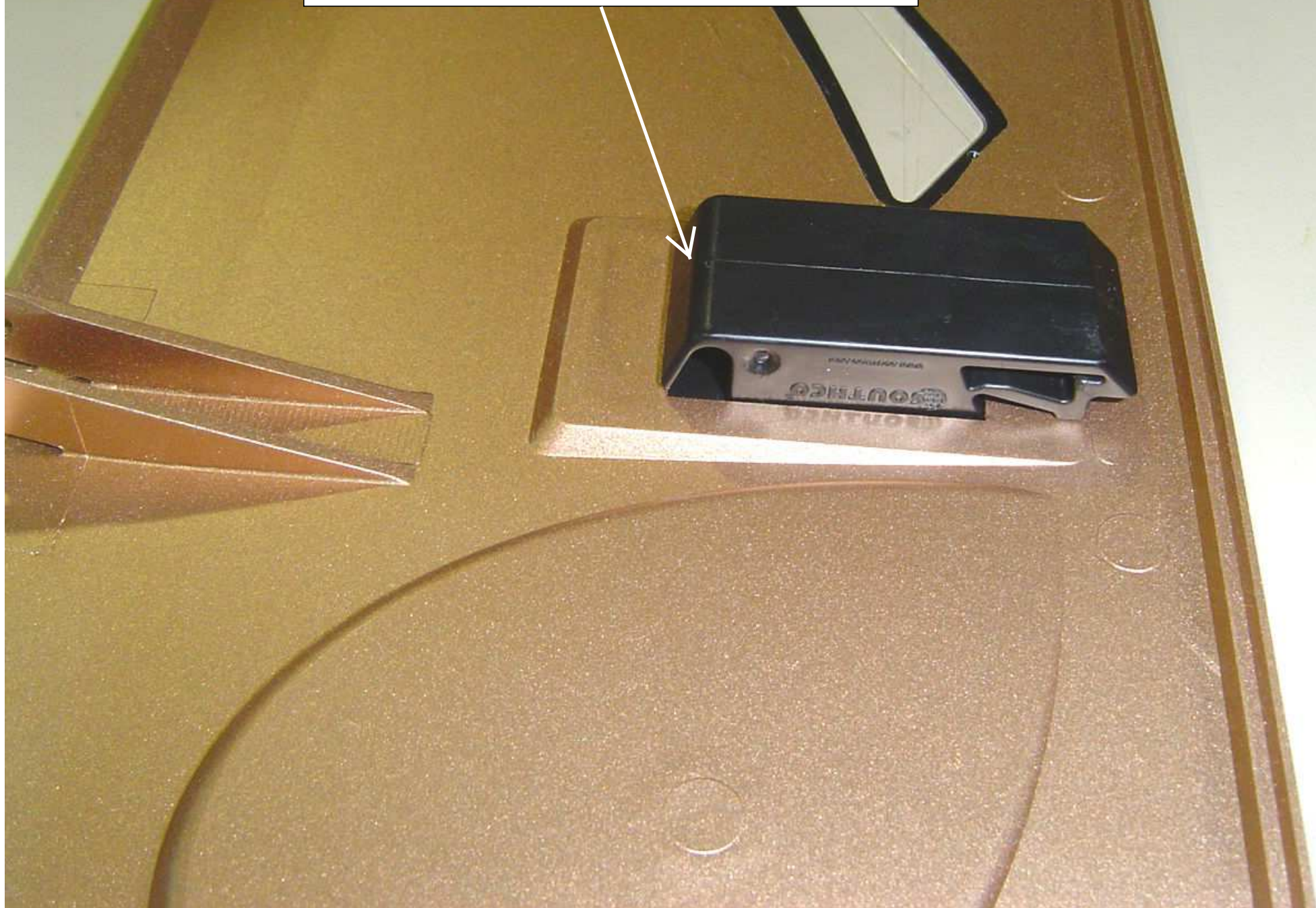

FIT THE SIDE CLOSING DOOR
INSERT THE OUTSIDE TOWARD
THE INSIDE (SEE NEXT
PICTURE)



DETAILS OF THE
DOOR MOUNTED

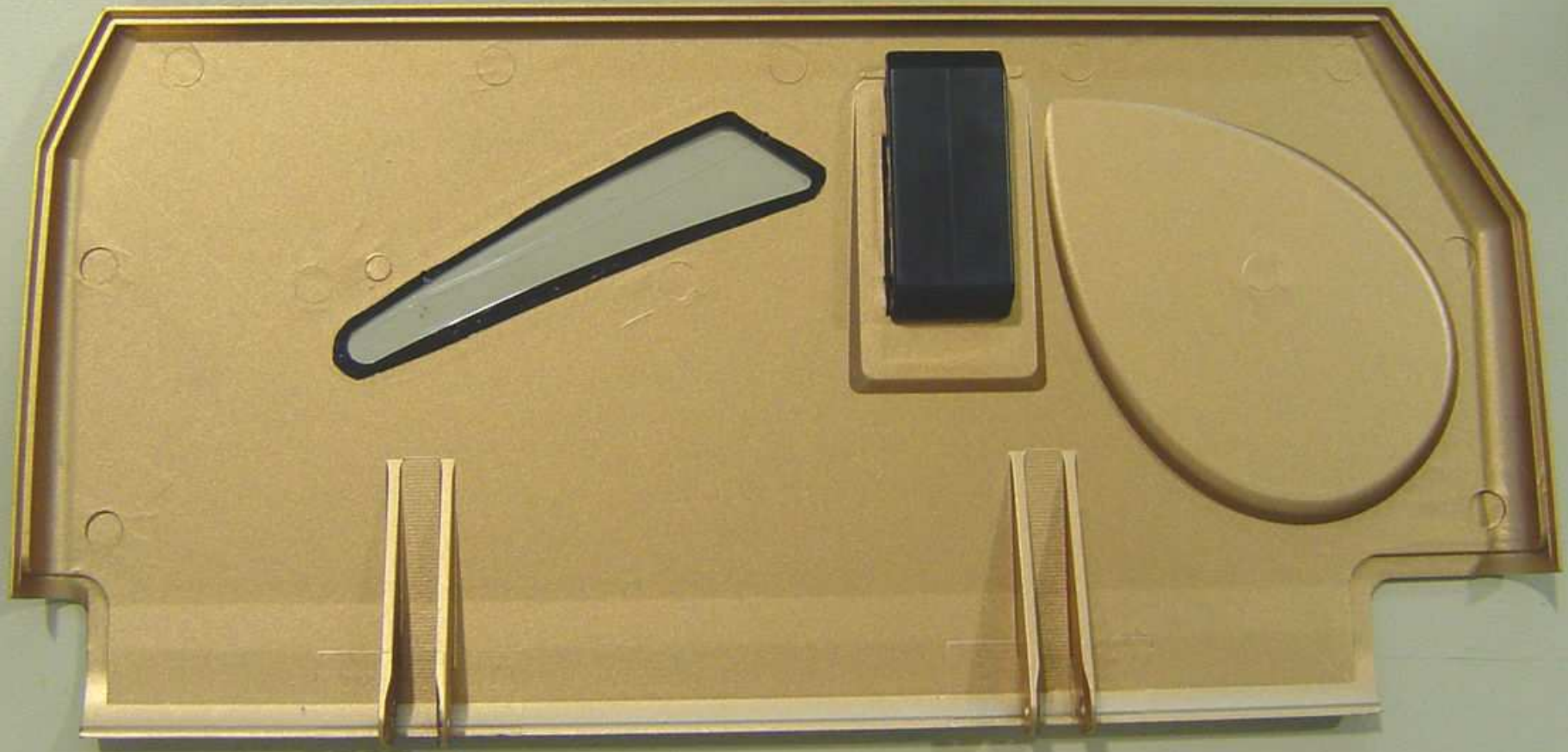

FIT DOOR
BASE
PIVOTS

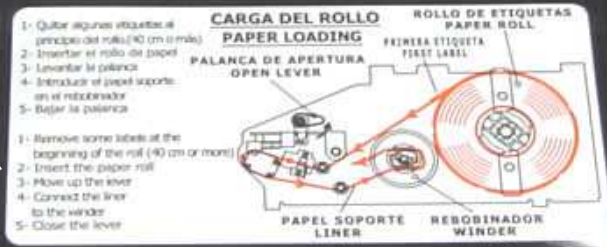

PASTE LABEL P/N.-
70010321 AT LABEL
PRINTER DOOR



TIGHTEN THE
RISERS P/N.-
72090066

DETAIL OF
CABLES BACK
LABEL PRINTER

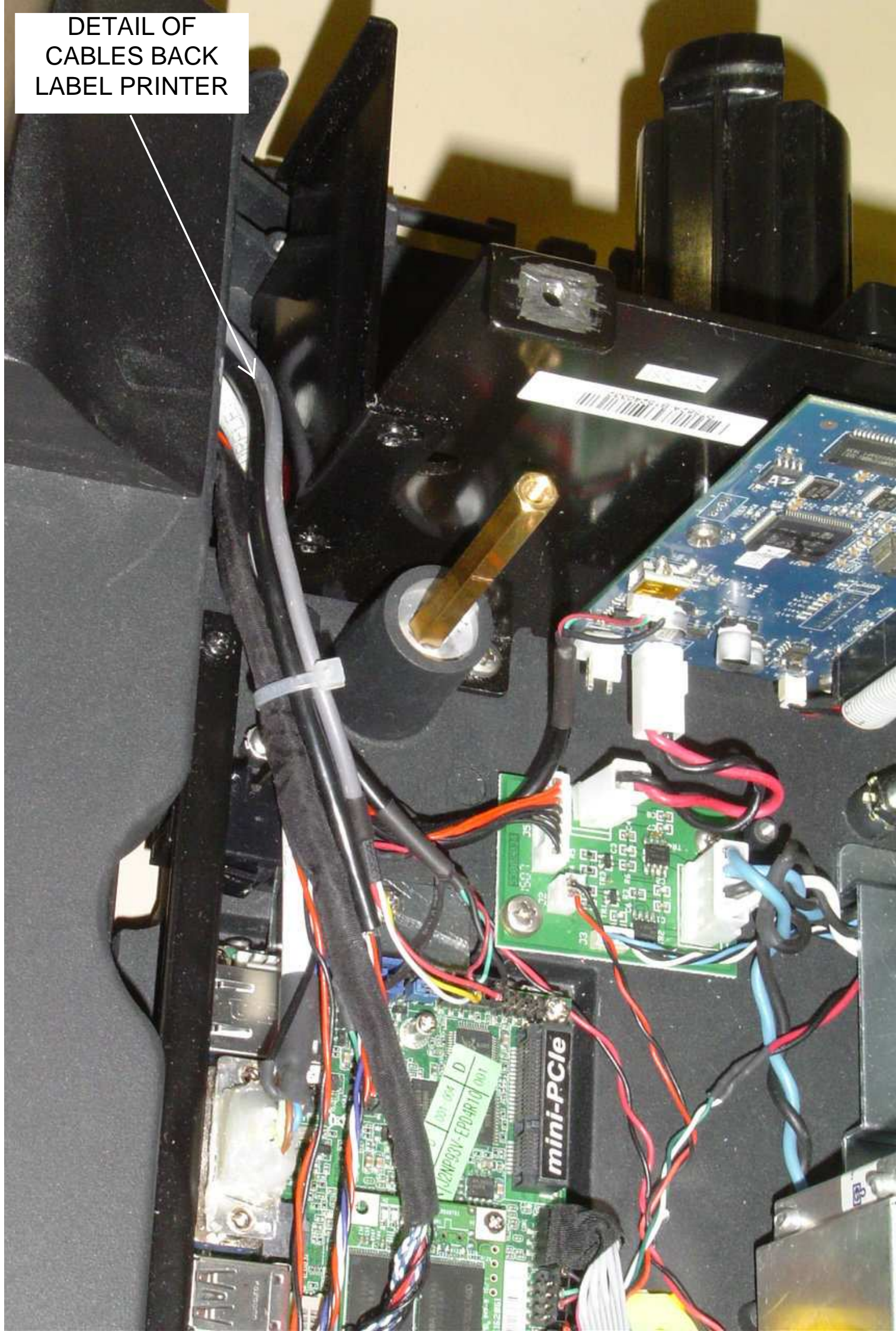

INSERT COVER RUBBER, IN THE
RIGHT POSITION, P/N.- 71000080 IN
COLUMN P/N.- 71002310



LONG SIDE

SHORT SIDE

PASS THE CABLES THROUGH THE COLUMN AND INSERTED INTO THE HOLLOW AT THE BASE

REMOVING THE CABLES P/N.- 90114098 AND P/N.- 90114099 FOR THE HOLLOW (SEE NEXT PICTURE)

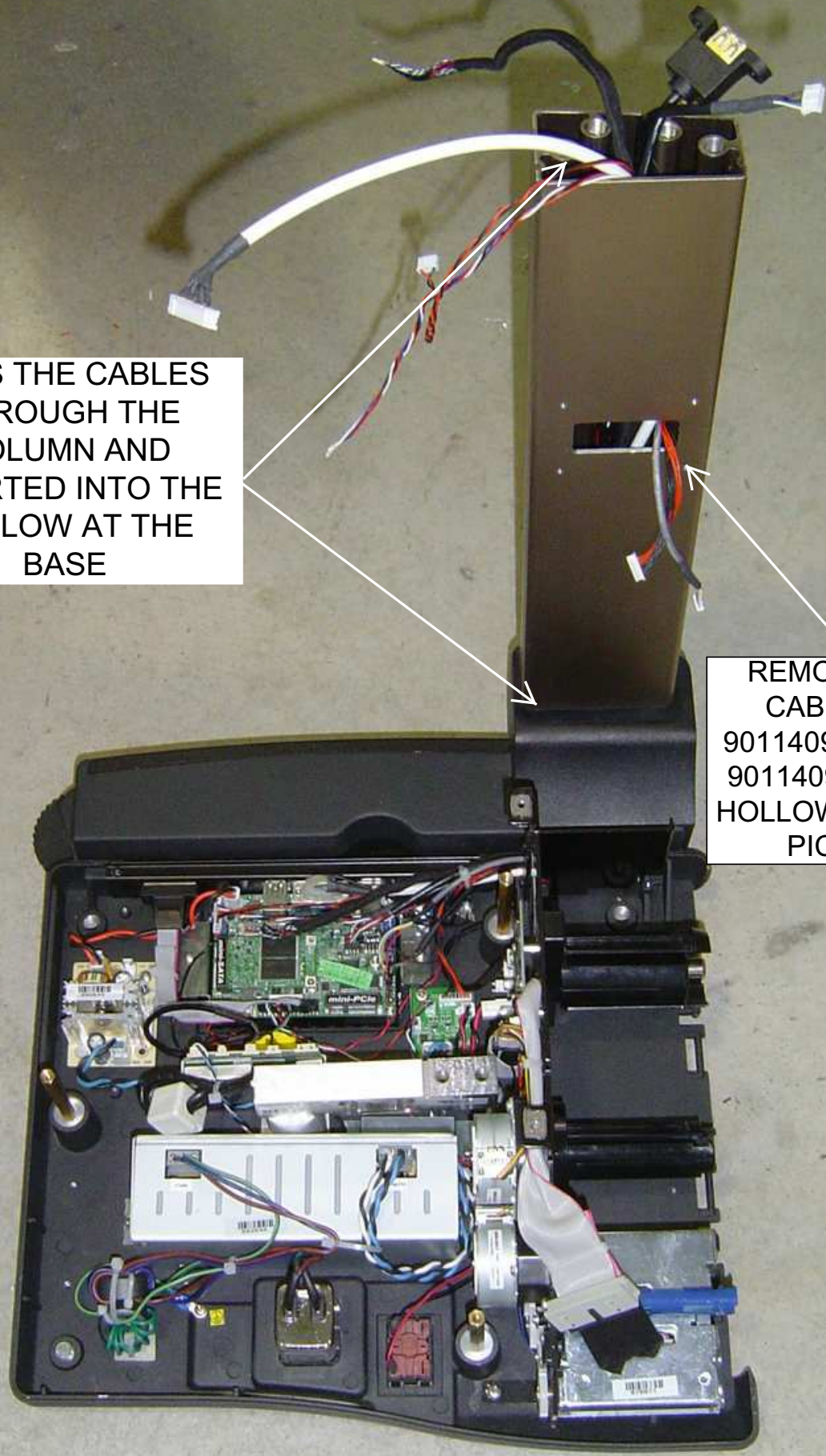

BE CAREFUL THAT
THE CABLES DO NOT
GO TO THE INSIDE

DETAIL OF THE OULET
OF THE CABLES P/N.-
90114098 AND P/N.-
90114099, FOR THE HOLE

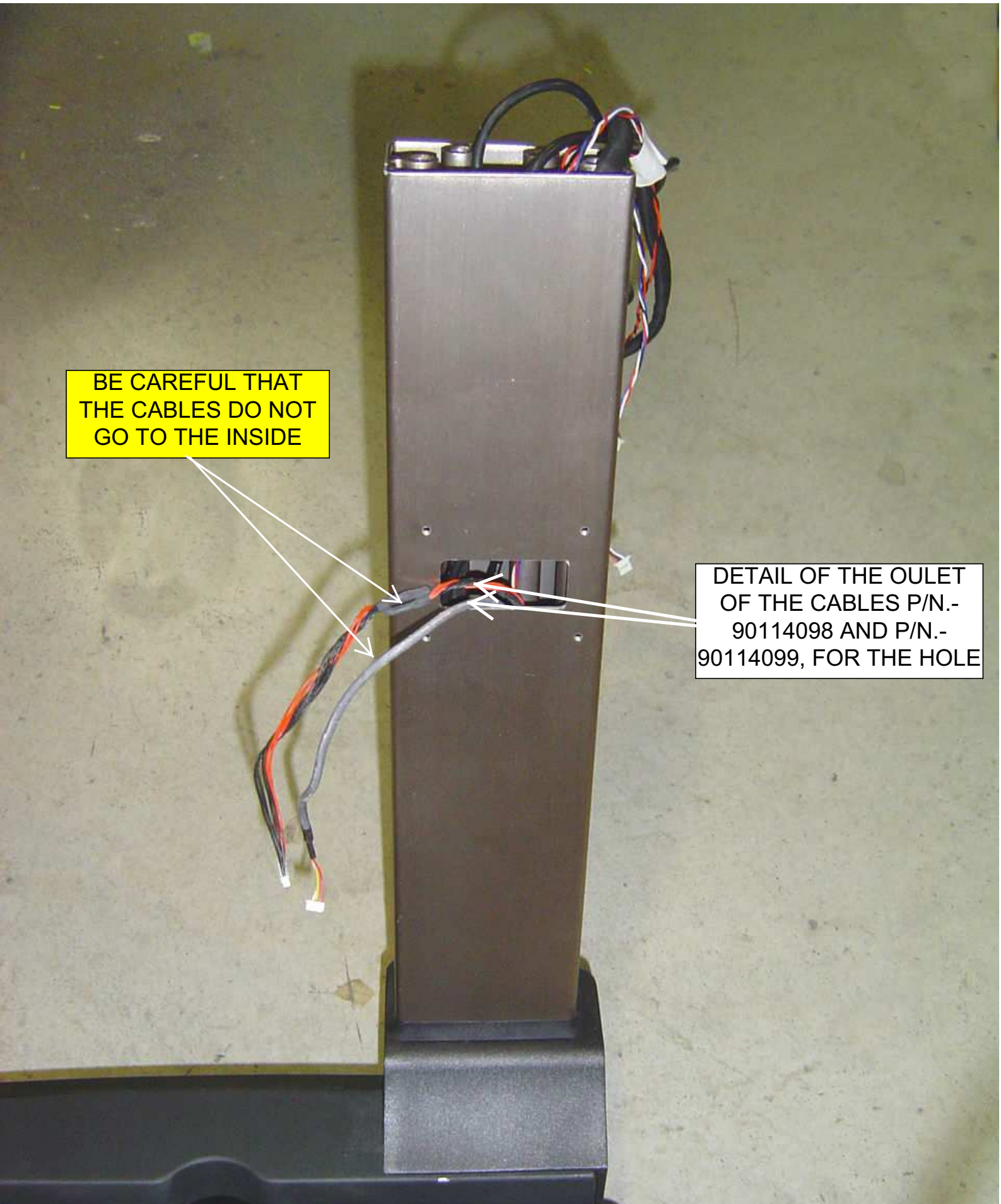

HOLD THE COLUMN WITH 2 SCREWS P/N.-
72062035. TIGHTEN WITH A REGULATED TOOL
TO A TIGHTENING TORQUE 11 Nm

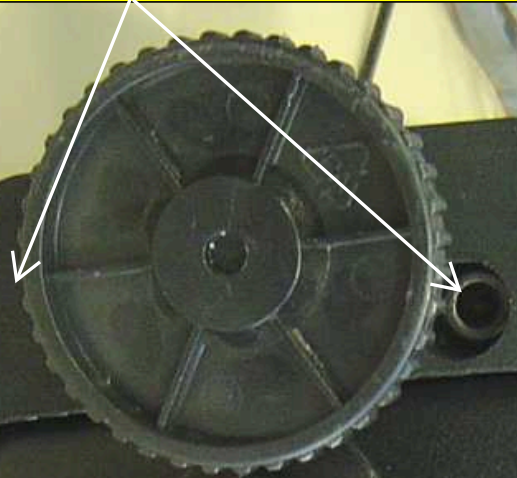

TO PUT COVER P/N.-
71001819



8.- ASSEMBLY COVER (COMPONENTS)

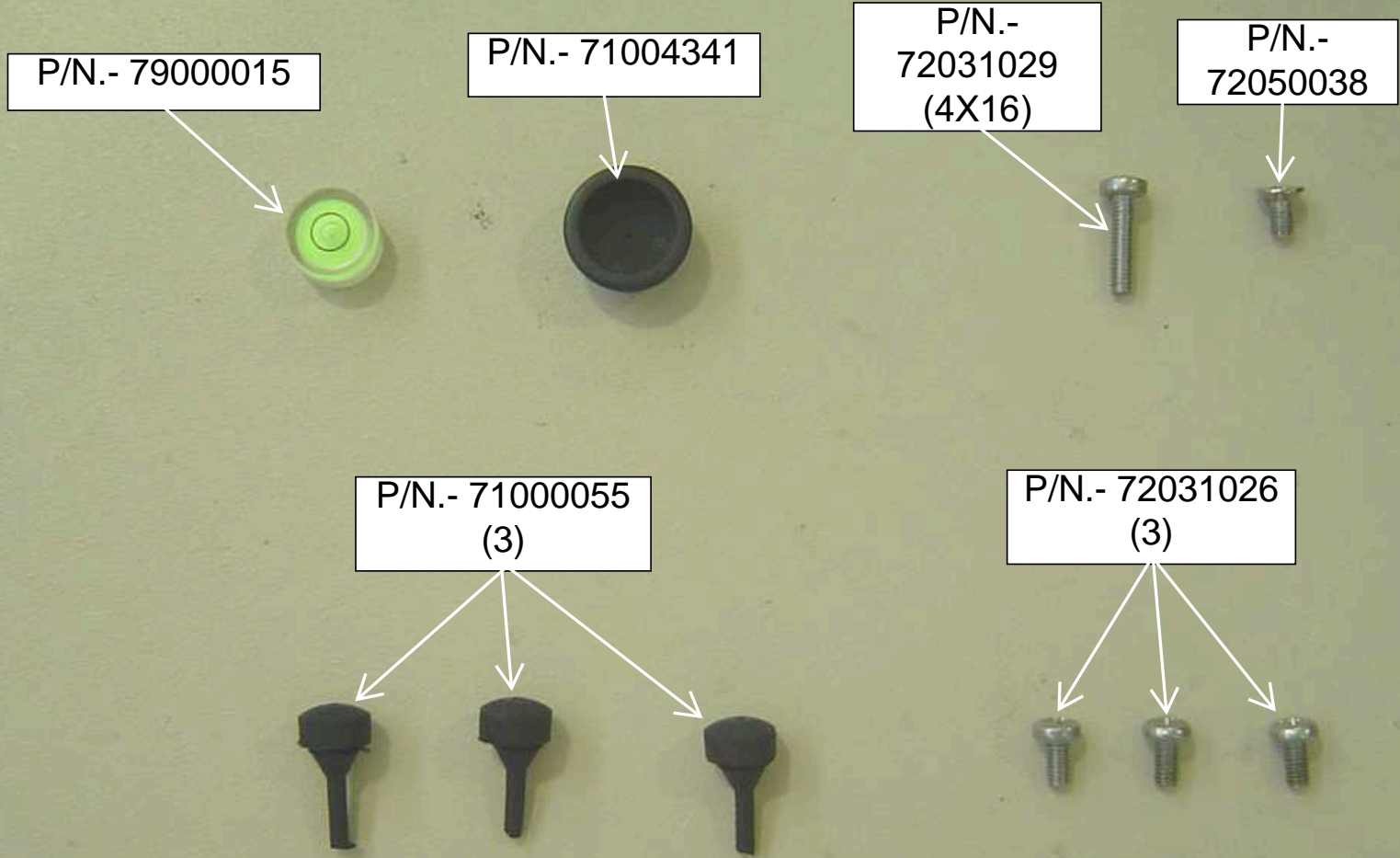

BE CAREFUL AND AVOID CAUGHT THE CABLES WITH THE HOUSING (SEE NEXT PICTURE)

P/N.- 71004437

P/N.- 71004341

P/N.- 79000015

P/N.- 72050038

P/N.- 72031026

P/N.- 72031029
(THIS SCREW IT IS FOR HOLD CABLE)

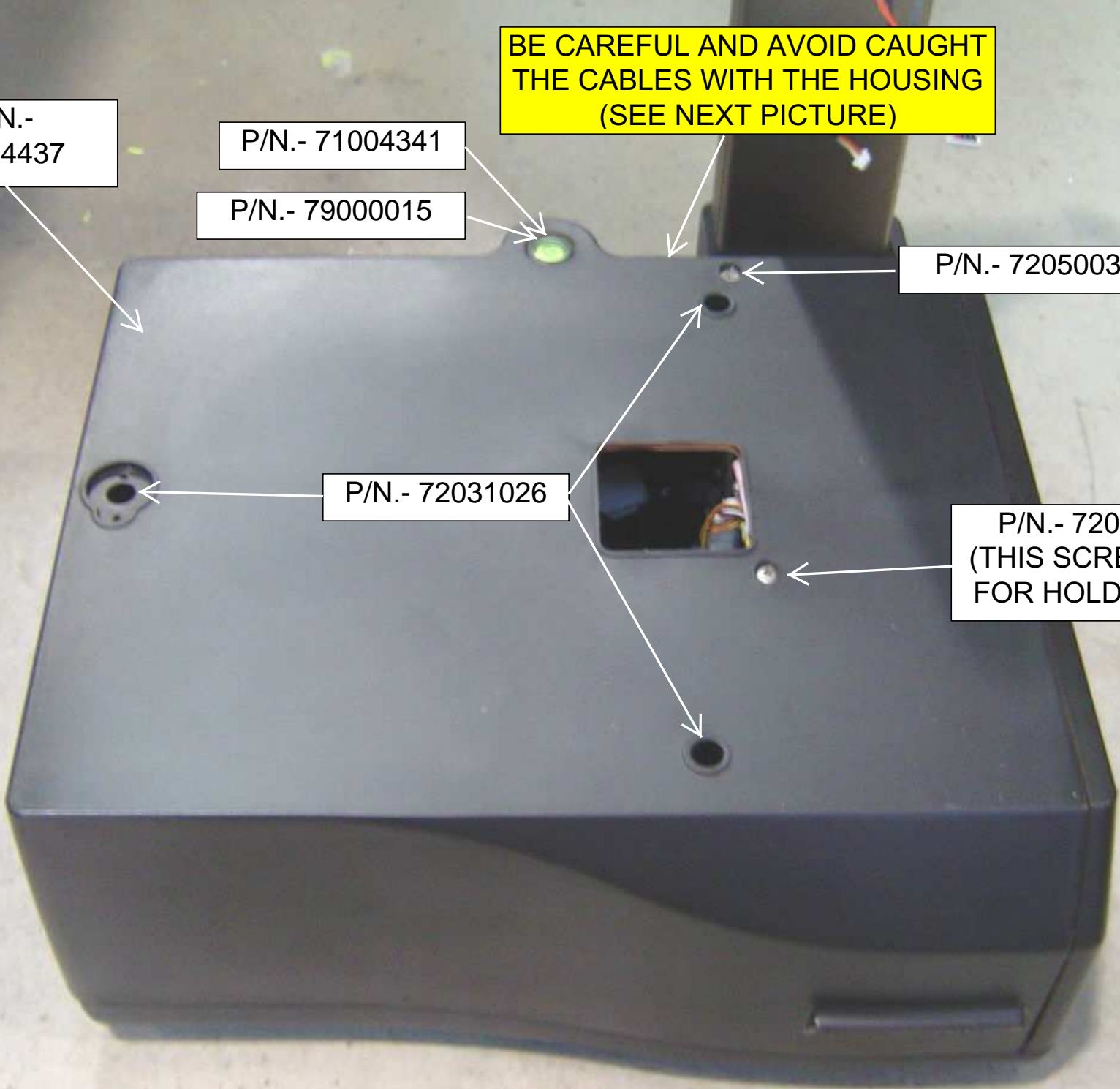

BE CAREFULL NOT TO
TAKE THE CABLE
WITH THE HOUSING





PUT THE
RUBBER
STOPPERS P/N.-
71000055

9.- ASSEMBLY UP CROSS AND PUT PAN SCALE (COMPONENTS)

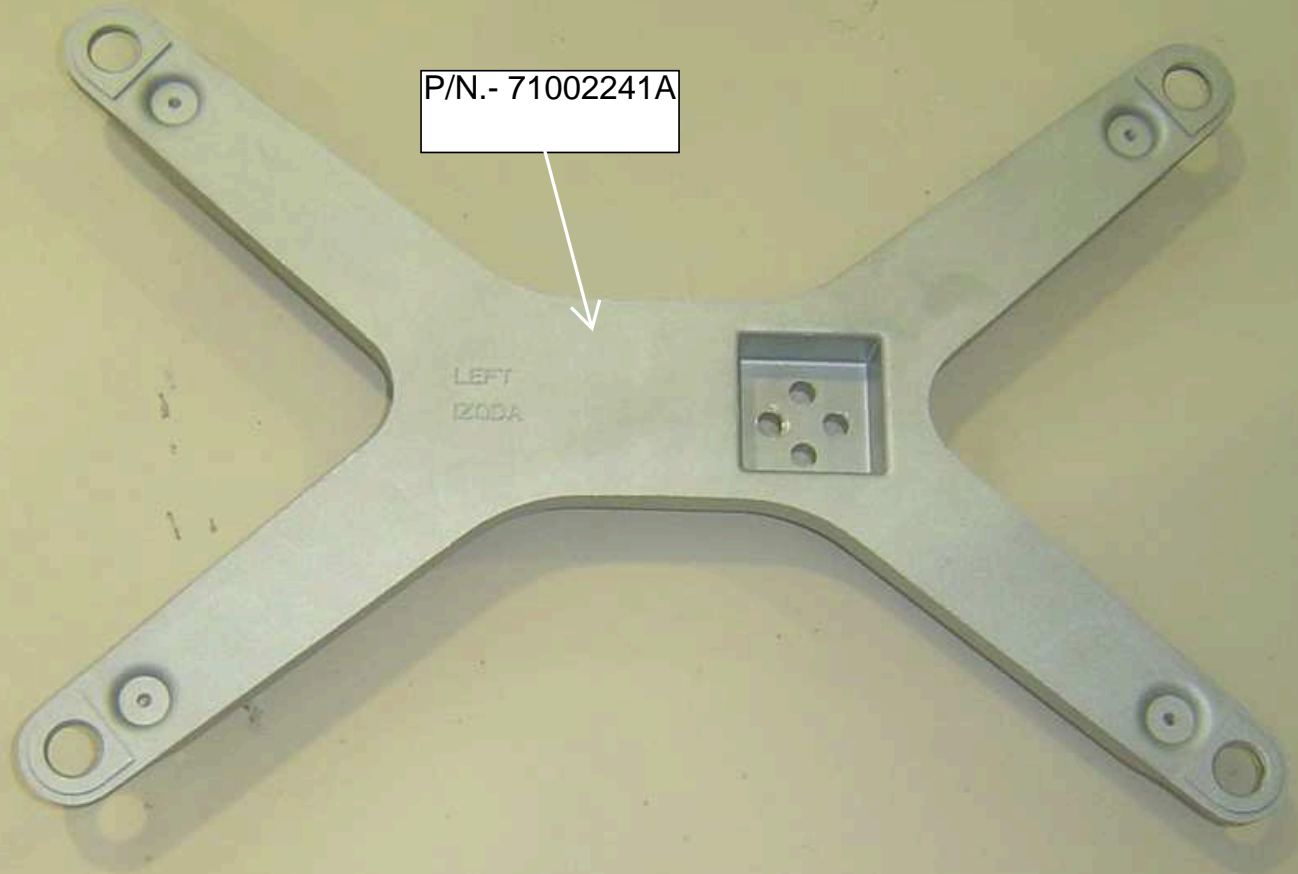

P/N.- 71002241A

P/N.-
71000078
(4)

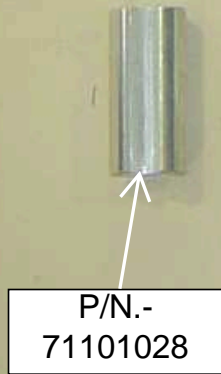

P/N.-
71101028

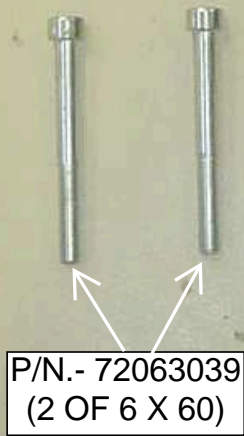

P/N.- 72063039
(2 OF 6 X 60)

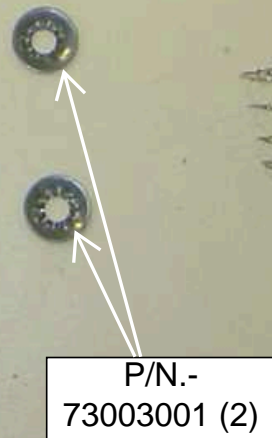

P/N.-
73003001 (2)

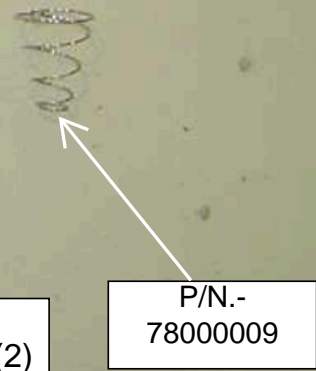

P/N.-
78000009

P/N.-
71101028



P/N.-
71002241A

P/N.- 73003001

P/N.-
71000078

PUT THE SPRING
P/N.- 78000009
HOLDING WITH
THE WHASER
AND THE SCREW

P/N.-
72063039

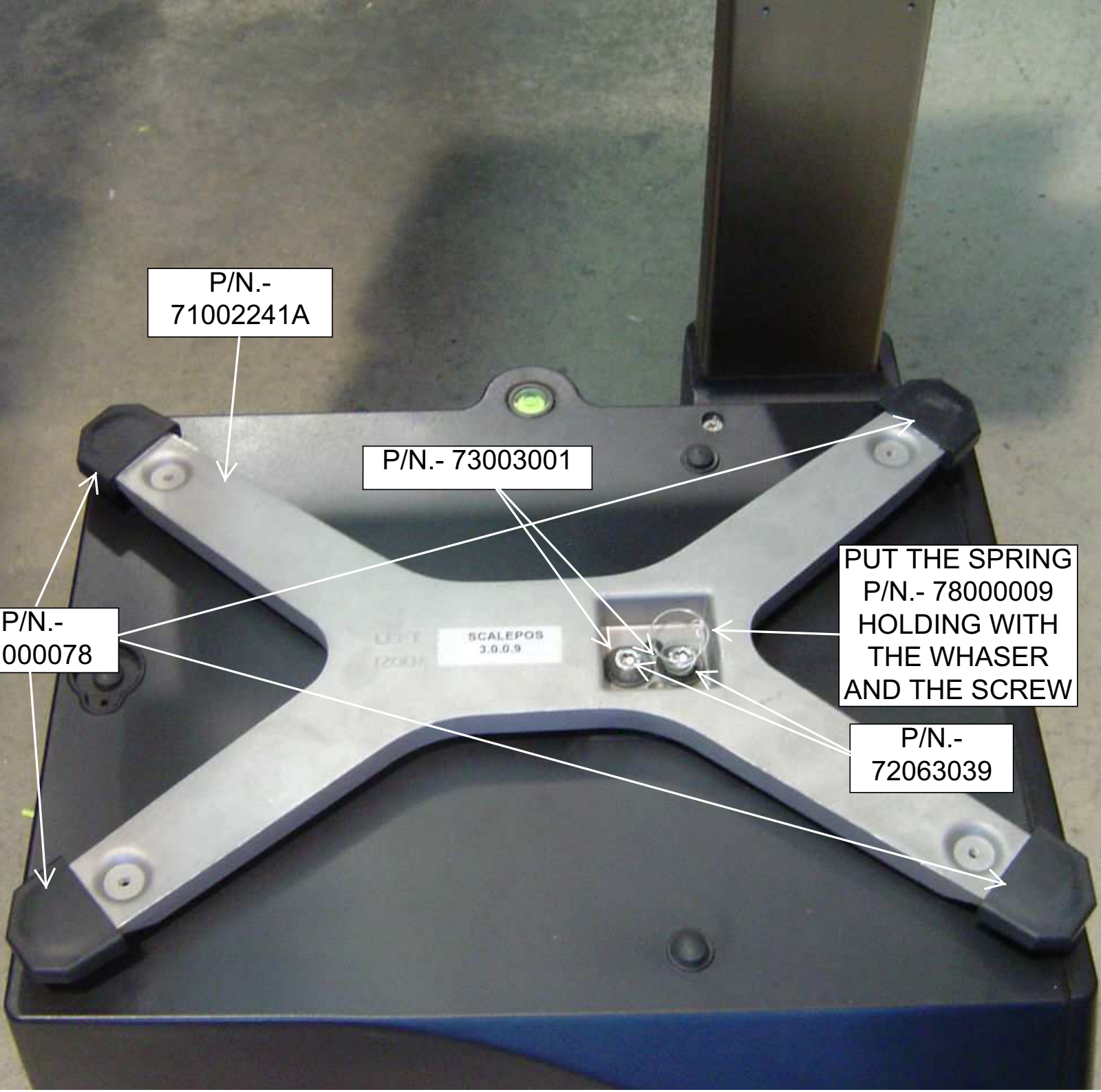



SCALEPOS
3.0.0.9

TIGHTEN WITH A
REGULATED
TOOL TO A
TIGHTENING
TORQUE 11 Nm

PUT THE PAN
SCALE P/N.-
71210246



10.- ASSEMBLY SUPPORT OF MONITORS (COMPONENTS)

P/N.-
72190004
(4)

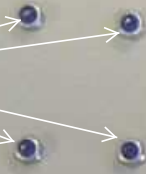

P/N.-
19087300



P/N.-
71000075



P/N.-
71100003
(4)

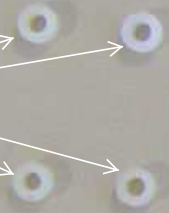

P/N.-
19087500



P/N.-
72054017
(2)

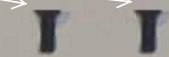

P/N.-
90114093



P/N.-
72062035
(2)



P/N.-
90114094



10.- ASSEMBLY SUPPORT OF MONITORS (COMPONENTS)

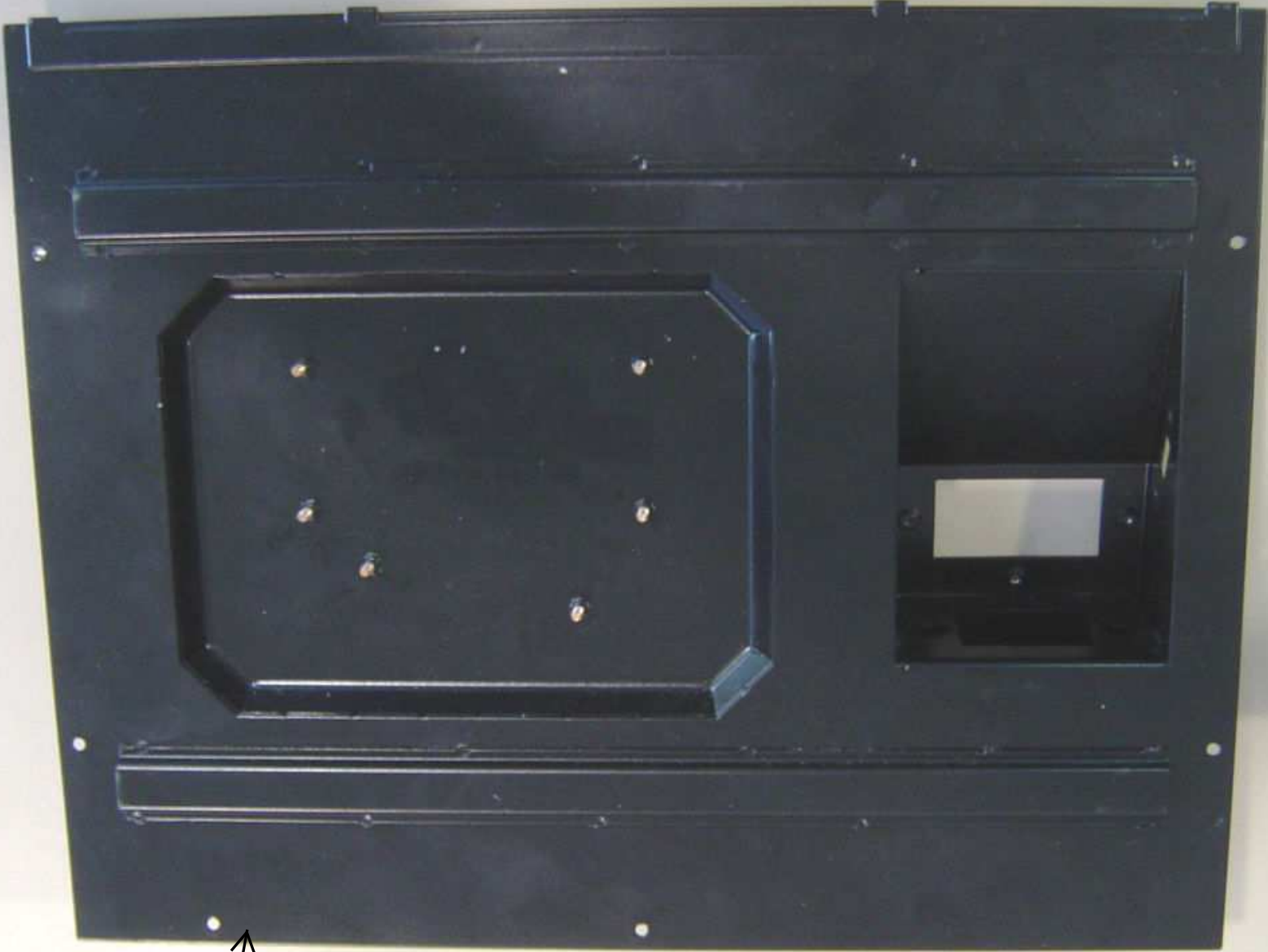

P/N.-
71210588

PASTE THE PIECE P/N.- 71000075
DOWN BOARD 19087500

HOLD THE BOARD P/N.-
19087500 WITH 2 NUTS P/N.-
72190004

CONNECT THE CABLE
P/N.- 90114093 AT
THIS POSITION AND
HOLD THE GROUND
TERMINAL WITH NUT

CONNECT THE
CABLE P/N.-
90114094

HOLD THE BOARD P/N.-
19087300 WITH 2 NUTS P/N.-
72190004

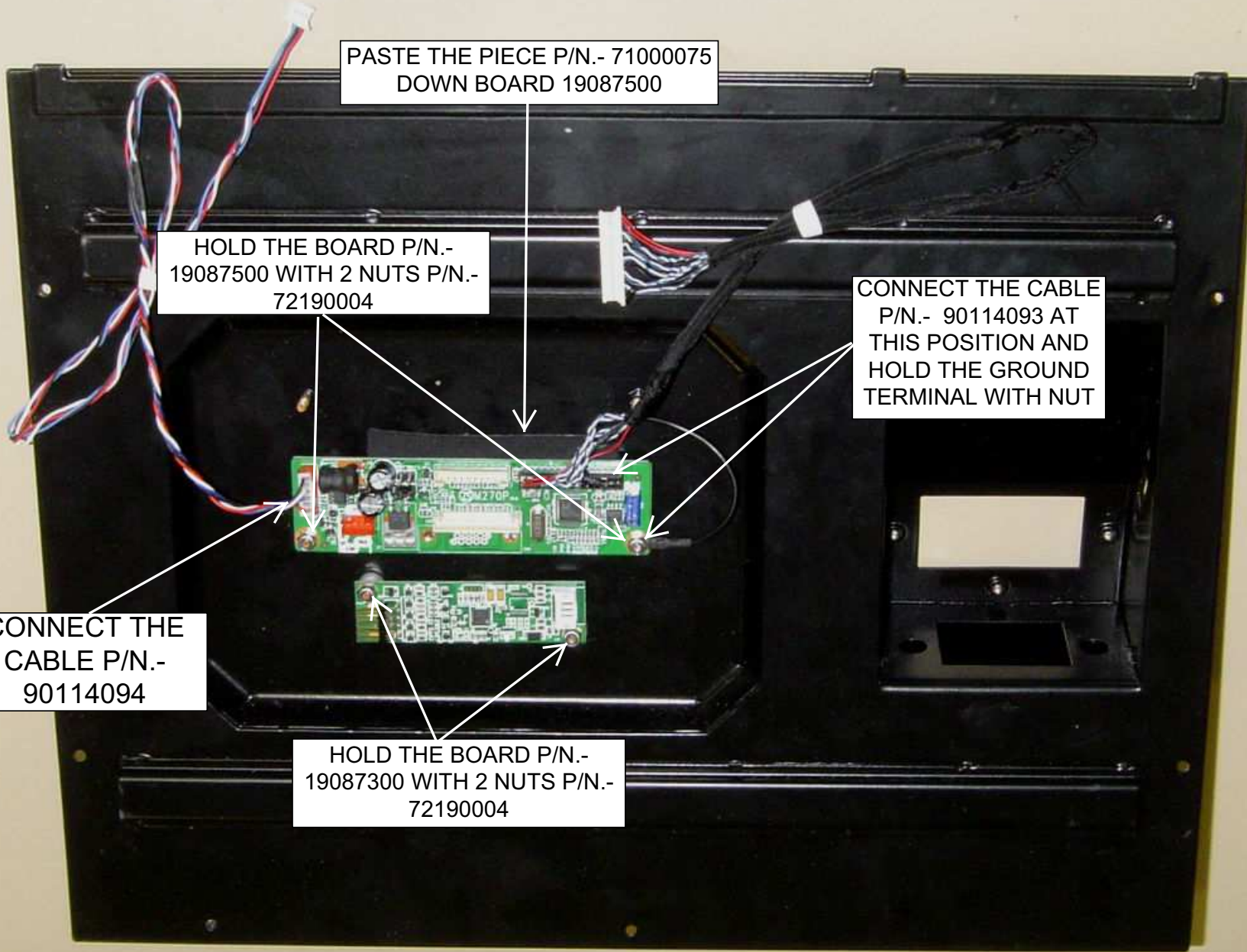

CONNECT
THE CABLE
P/N.-
90114097

HOLD THE CABLE
P/N.- 90114091
WITH 2 SCREWS
P/N.- 72054017
(SEE NEXT
PICTURE)

CONNECT THE CABLE
P/N.- 90114090

HOLD THE
PIECE P/N.-
71210588 WITH 2
SCREWS P/N.-
72062035
TIGHTEN WITH A
REGULATED
TOOL TO A
TIGHTENING
TORQUE 11 Nm

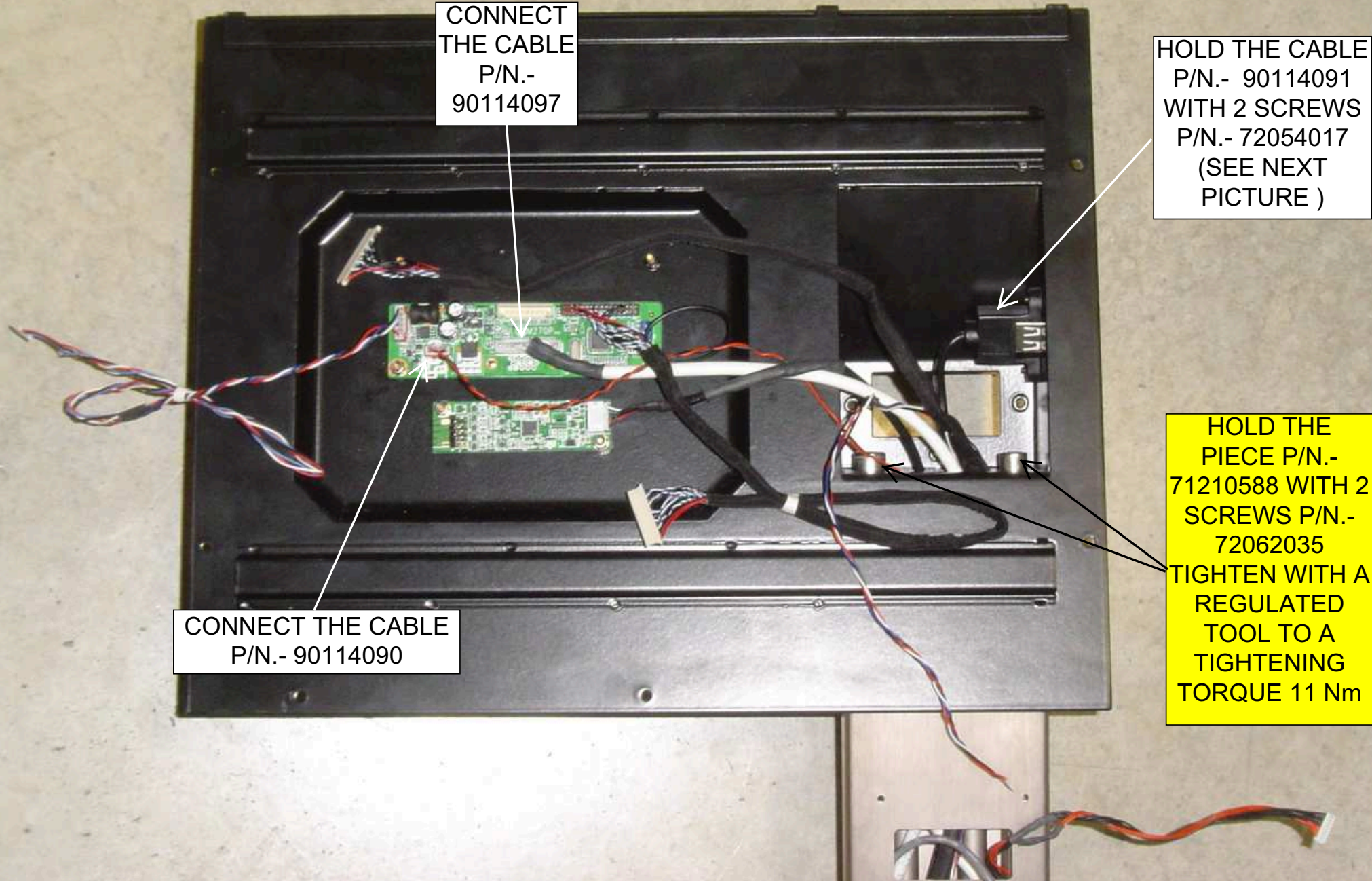

HOLD THE PIECE P/N.- 71210588
WITH 2 SCREWS P/N.- 72062035
TIGHTEN WITH A REGULATED
TOOL TO A TIGHTENING TORQUE
11 Nm



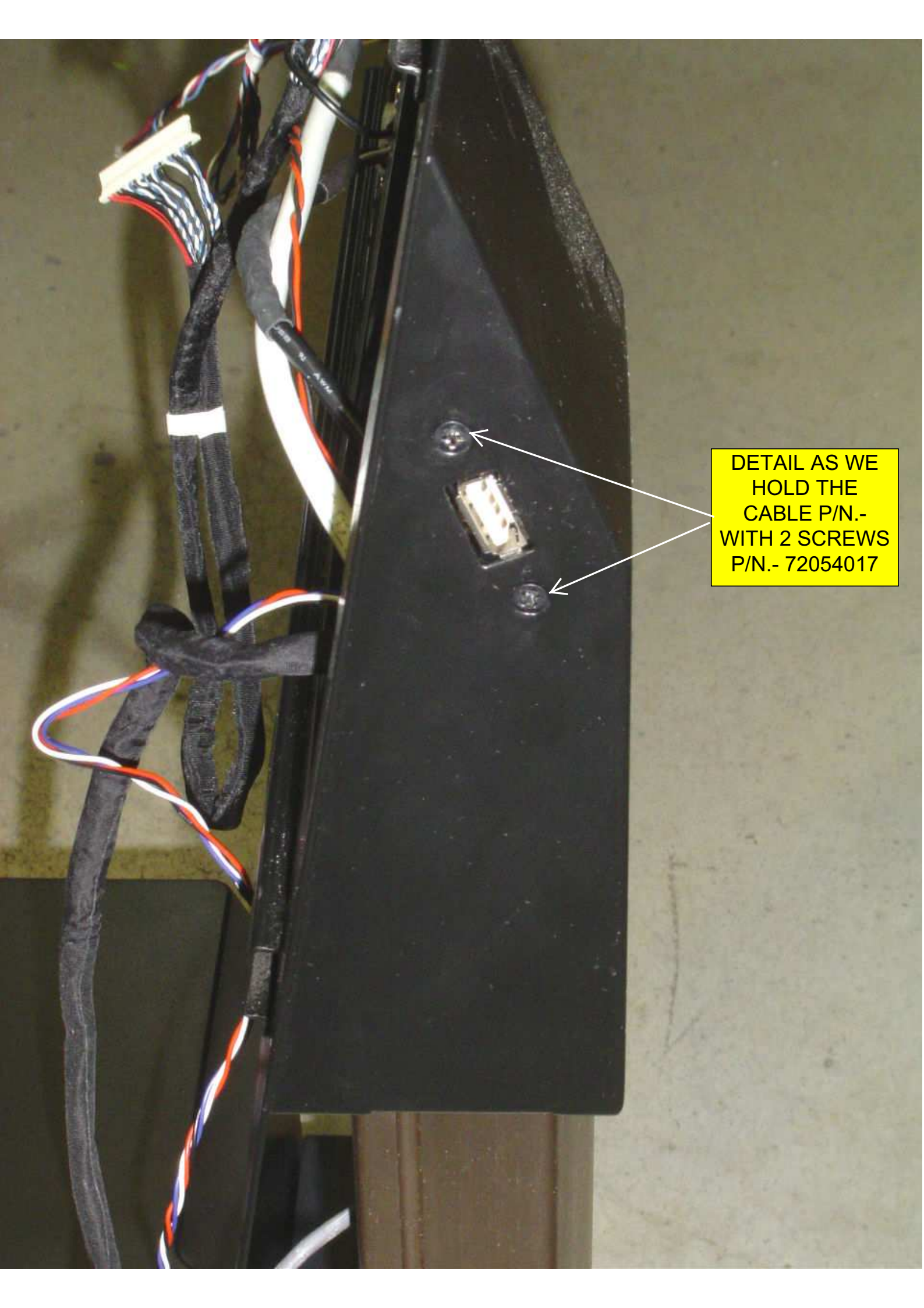

DETAIL AS WE
HOLD THE
CABLE P/N.-
WITH 2 SCREWS
P/N.- 72054017

11.- ASSEMBLY 15" FRONT MONITOR (COMPONENTES)



P/N.-
71210523 (2)

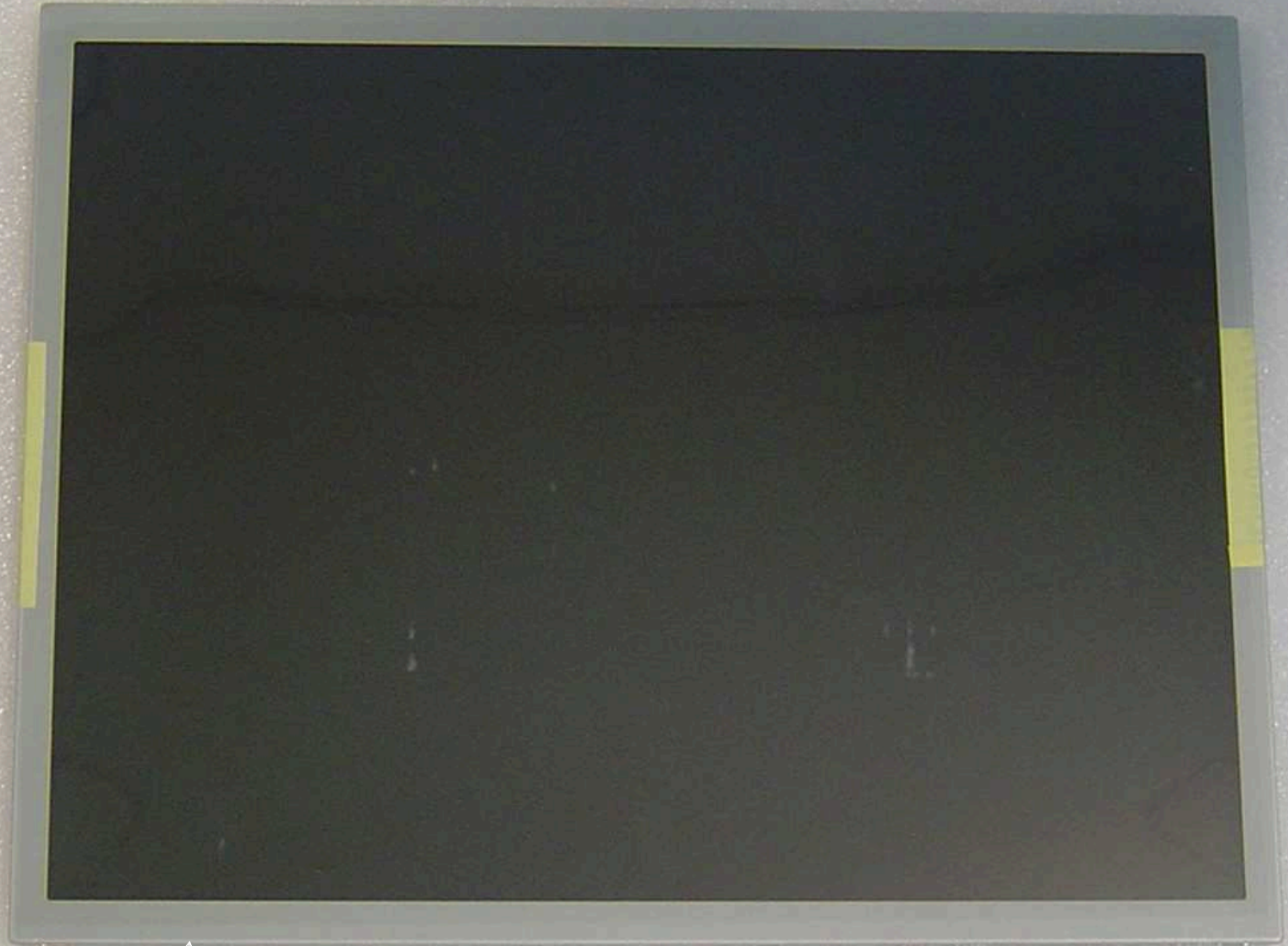

P/N.-
19019300



P/N.- 72200009
(3 mm)(4)



P/N.- 72031015
(4)

11.- ASSEMBLY 15" FRONT MONITOR (COMPONENTS)

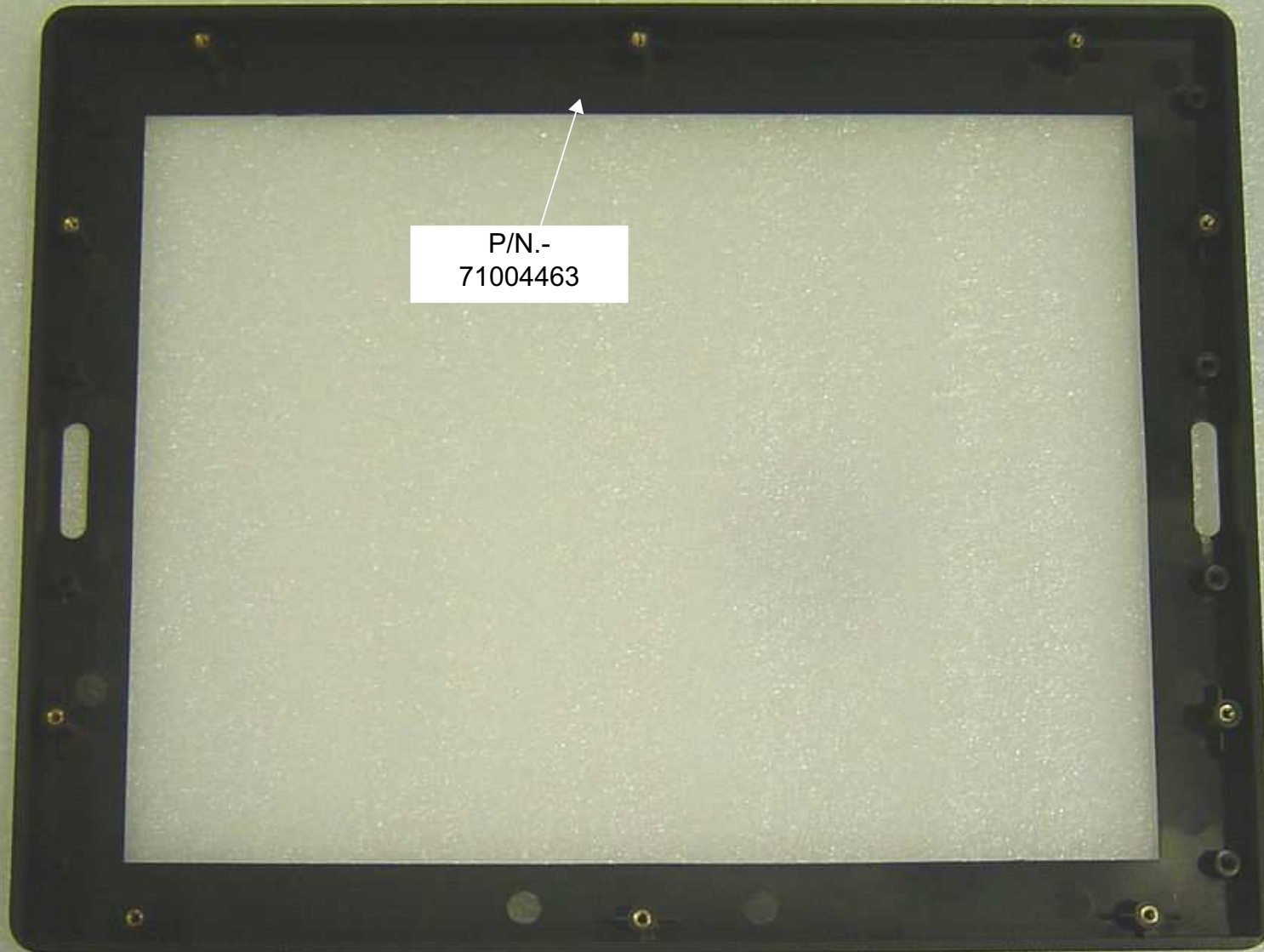

P/N.-
71004463



P/N.- 72201011 (4 mm)
(8)



P/N.- 72056007
(8)



P/N.- 72054017
(6)

11.- ASSEMBLY 15" FRONT MONITOR (COMPONENTS)

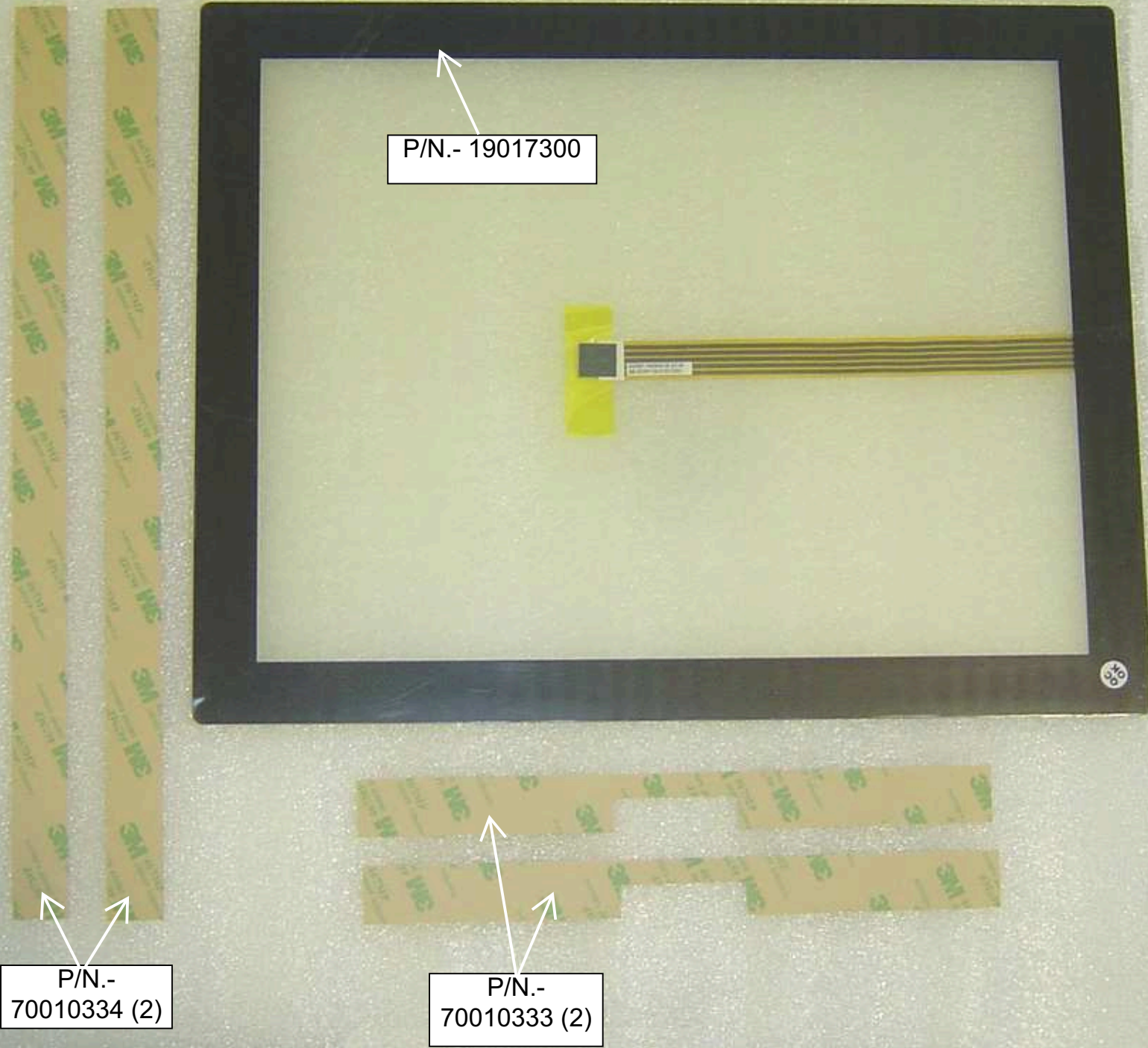

P/N.- 19017300

P/N.-
70010334 (2)

P/N.-
70010333 (2)

PUT THE
MONITOR
SUPPORT IN
LINE WITH THE
SAME



HOLD THE MONITOR SUPPORT
WITH WASHERS P / N.- 72200009
AND SCREWS P / N.- 72031015

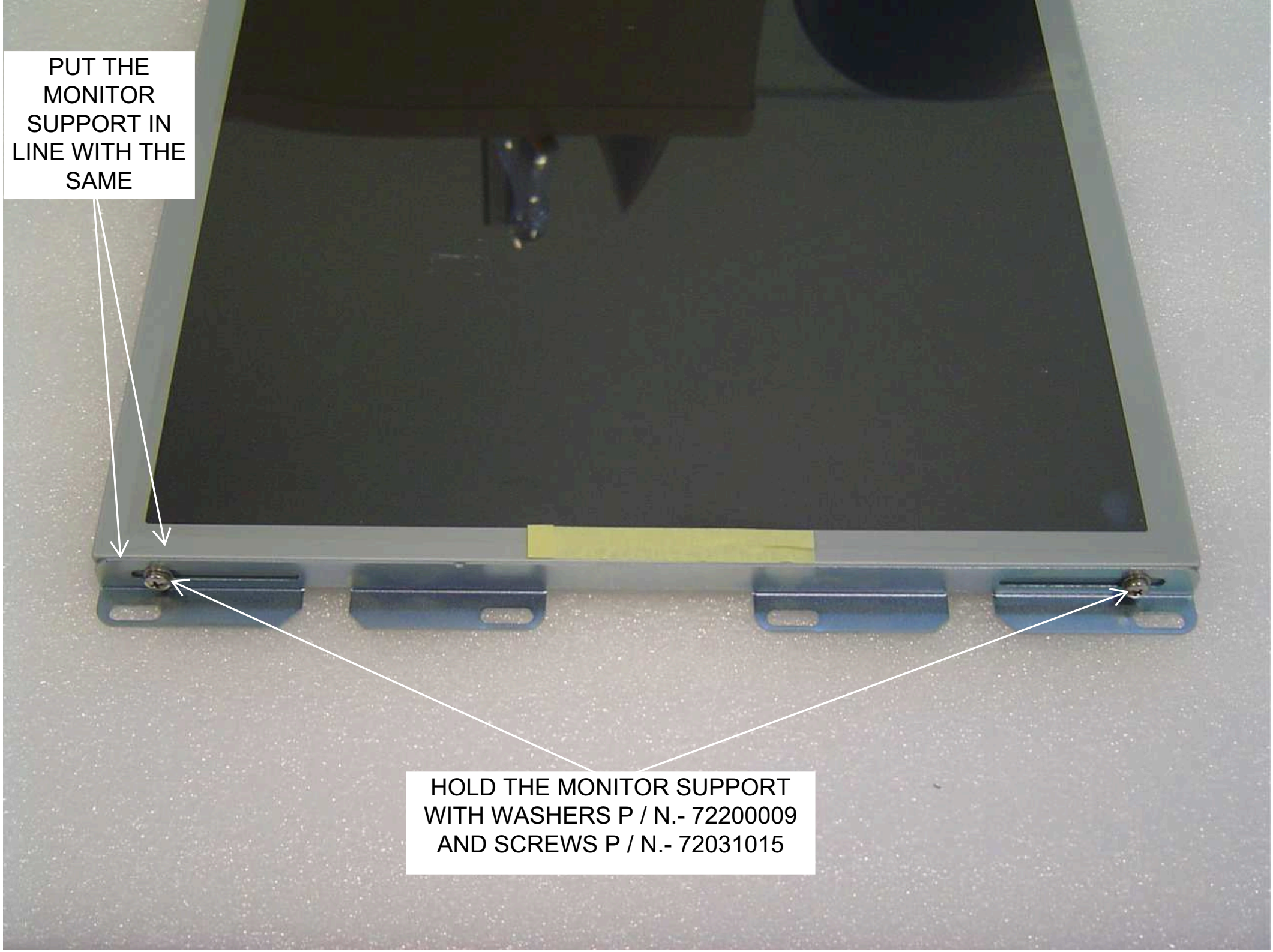

VIEW OTHER SIDE OF
MONITOR

PUT THE
MONITOR
SUPPORT IN
LINE WITH THE
SAME

HOLD THE MONITOR SUPPORT
WITH WASHERS P / N.- 72200009
AND SCREWS P / N.- 72031015



ASSEMBLY VIEW

REMOVE THE
MONITOR PROTECTOR
BEFORE PUTTING IT
ON THE SUPPORT

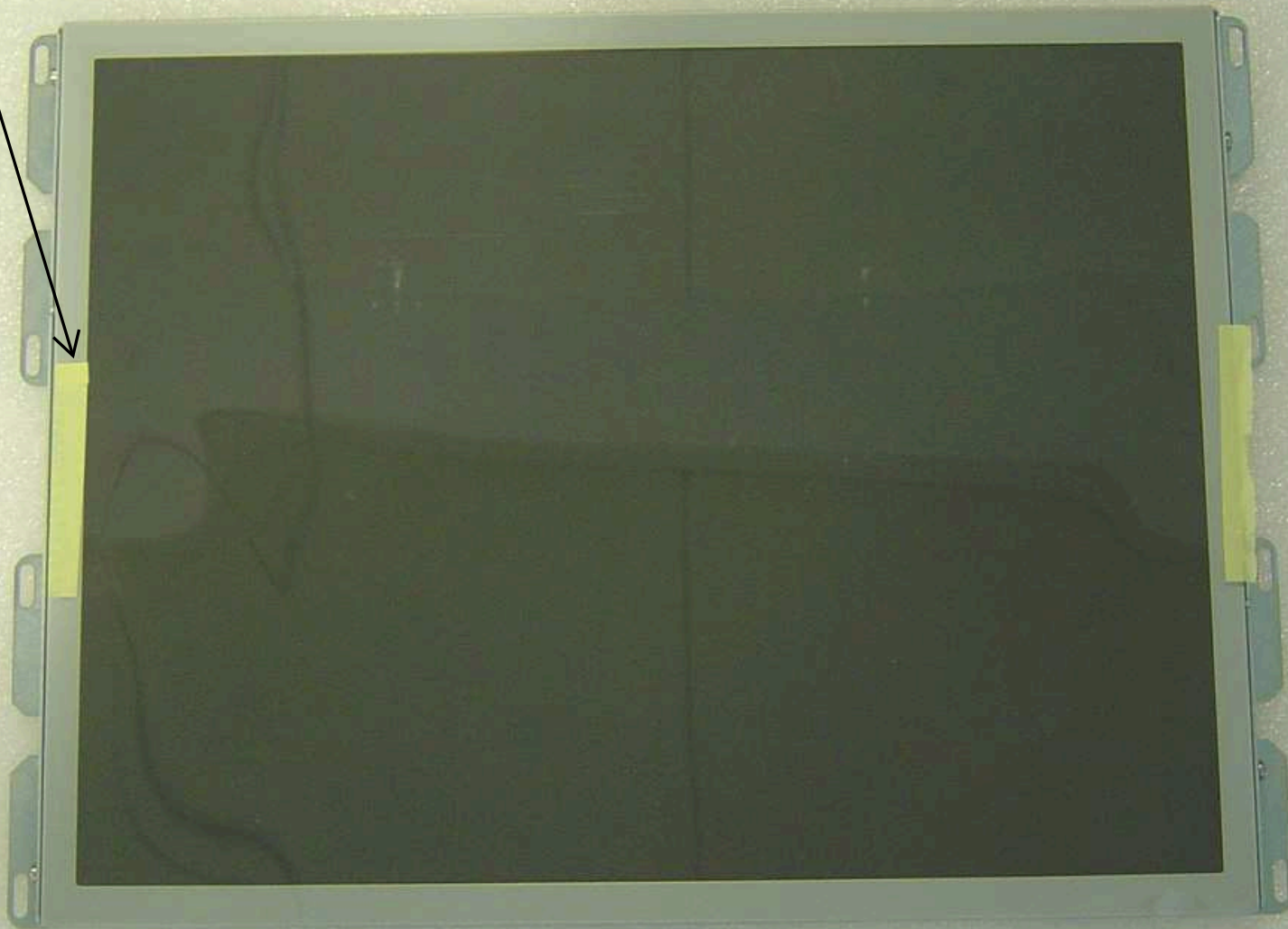

PUT THE MONITOR IN THIS POSITION. LOW TOWERS

HOLD IT WITH 8 WASHERS P / N.- 72201011 AND 8 SCREWS P / N.- 73036007. BEFORE TIGHTEN THE SCREWS BE SURE THE MONITOR IS CENTERED AND THE PLATED BORDERS ARE NOT VIEWED ON THE VISION WINDOW (SEE NEXT IMAGE)

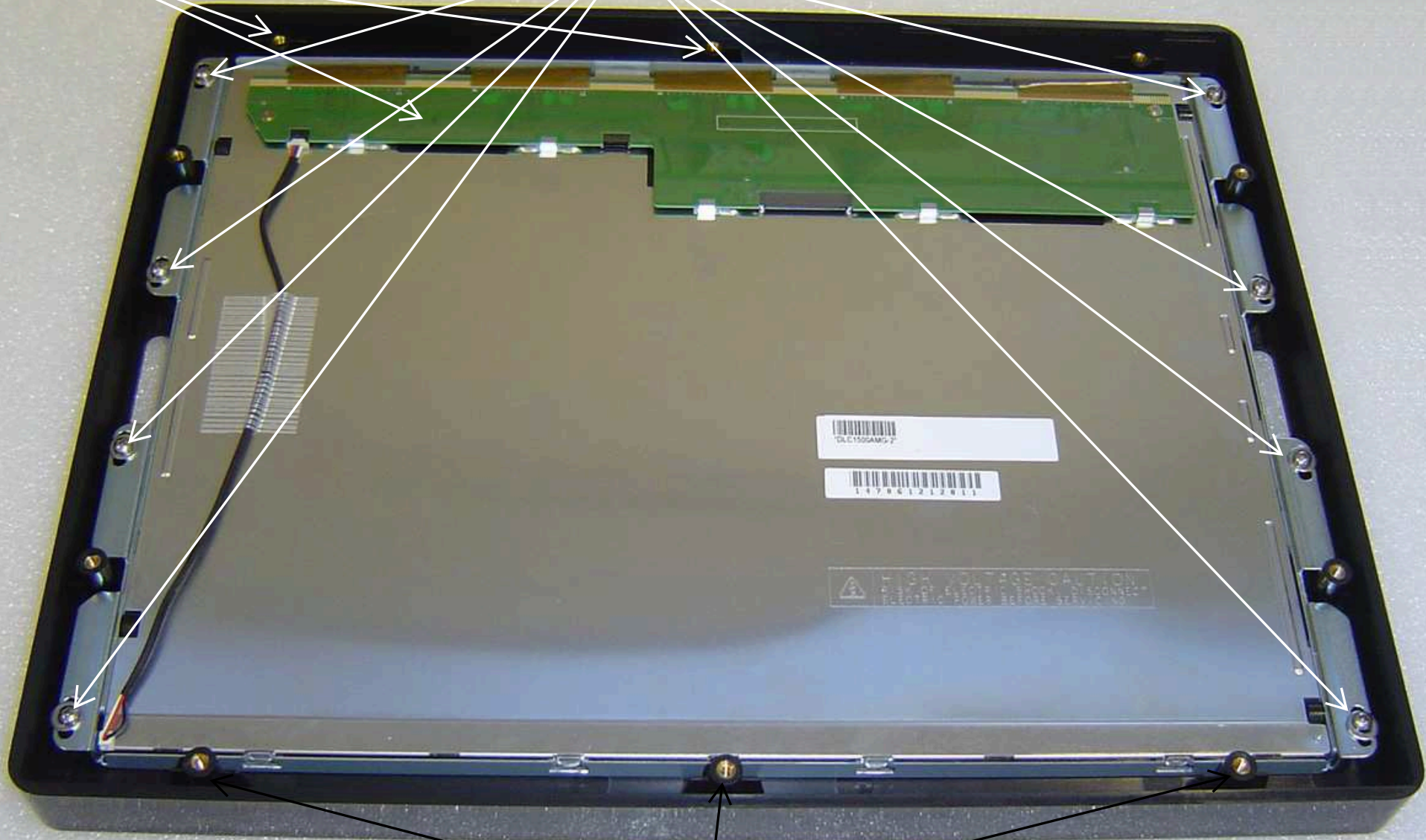

HIGH TOWERS SUPPORT

CENTERING THE
MONITOR TO PREVENT
THE VIEW OF THE
PLATED EDGE

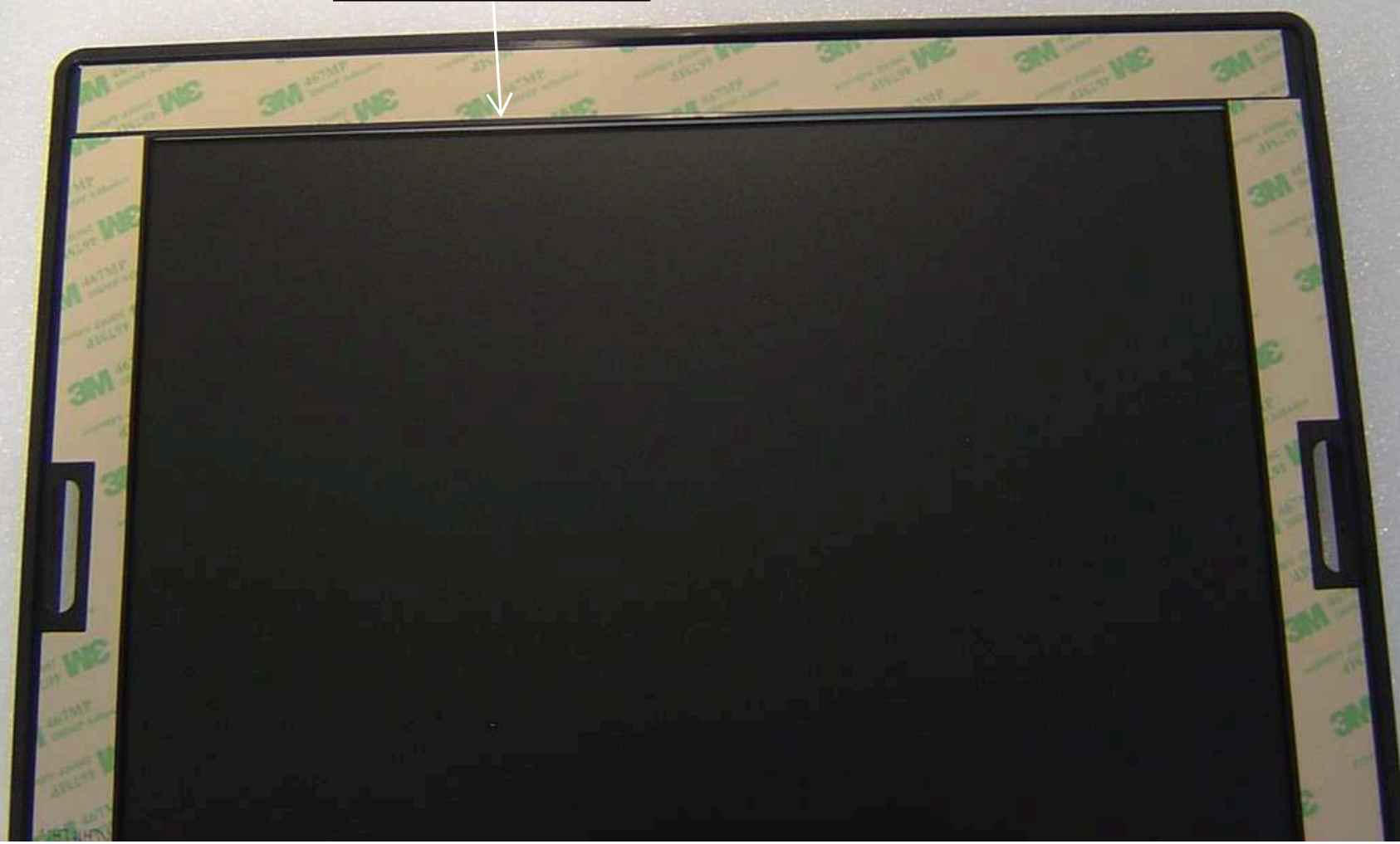

TIGHTEN THE ADHESIVE STRIPS P / N.-
70010333 AND 70010334 TO THE
MONITOR HOUSING . ALSO REMOVE THE
PROTECTOR OF THE EXTERNAL PART TO
PICK THE TOUCH

P/N.-
70010334

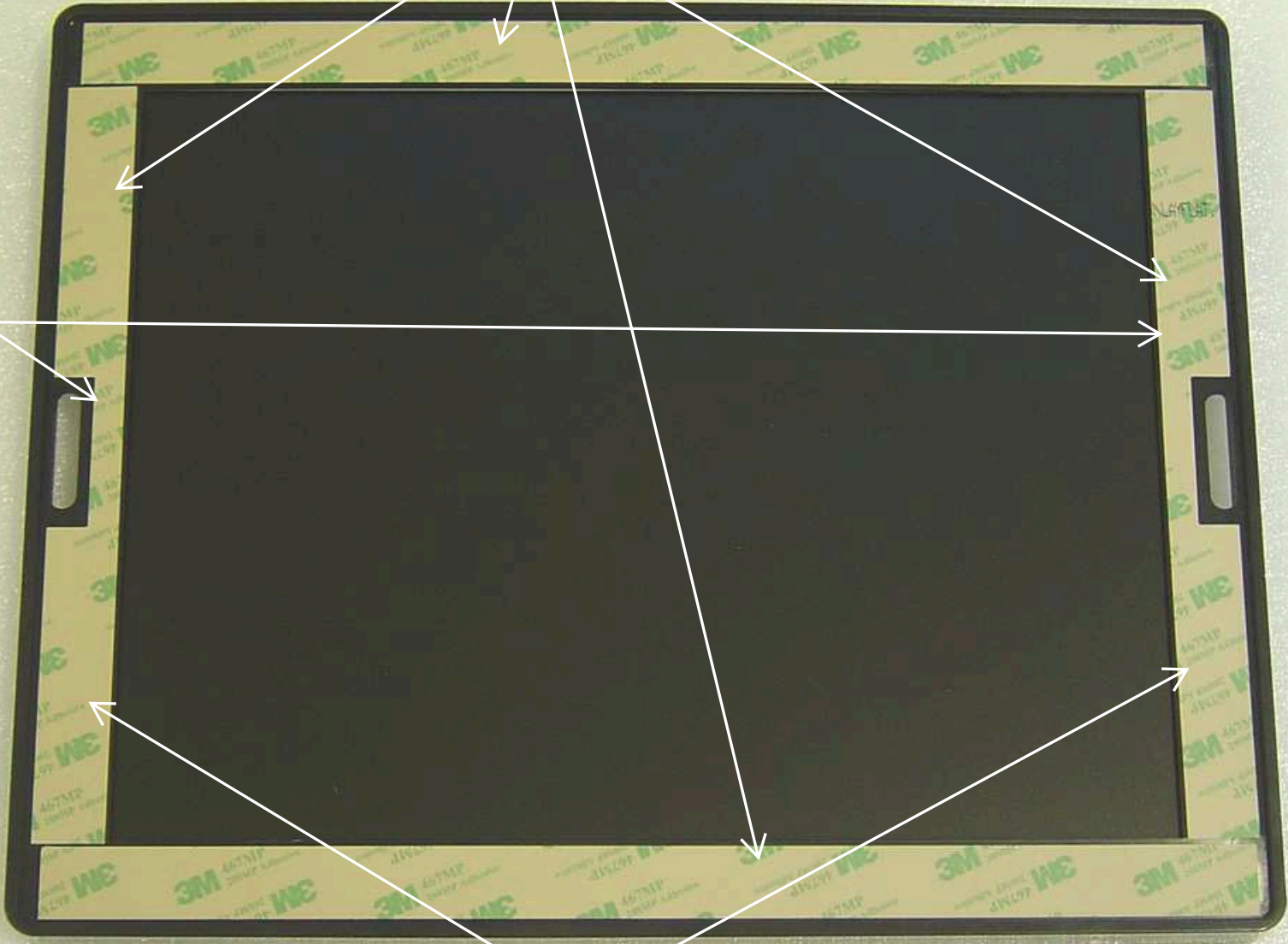

P/N.-
70010333

OVERVIEW



REMOVE THE TOUCH INTERNAL PROTECTOR BEFORE PICKING IT

INSERT THE TOUCH IN THE SPACE OF THE CASE AND PLACE IT IN THE ADHESIVE TAPES. INSERT THE CABLE BY THE HOLLOW OF THE LEFT PART



OVERVIEW BACK
SIDE

TOUCH
CABLE

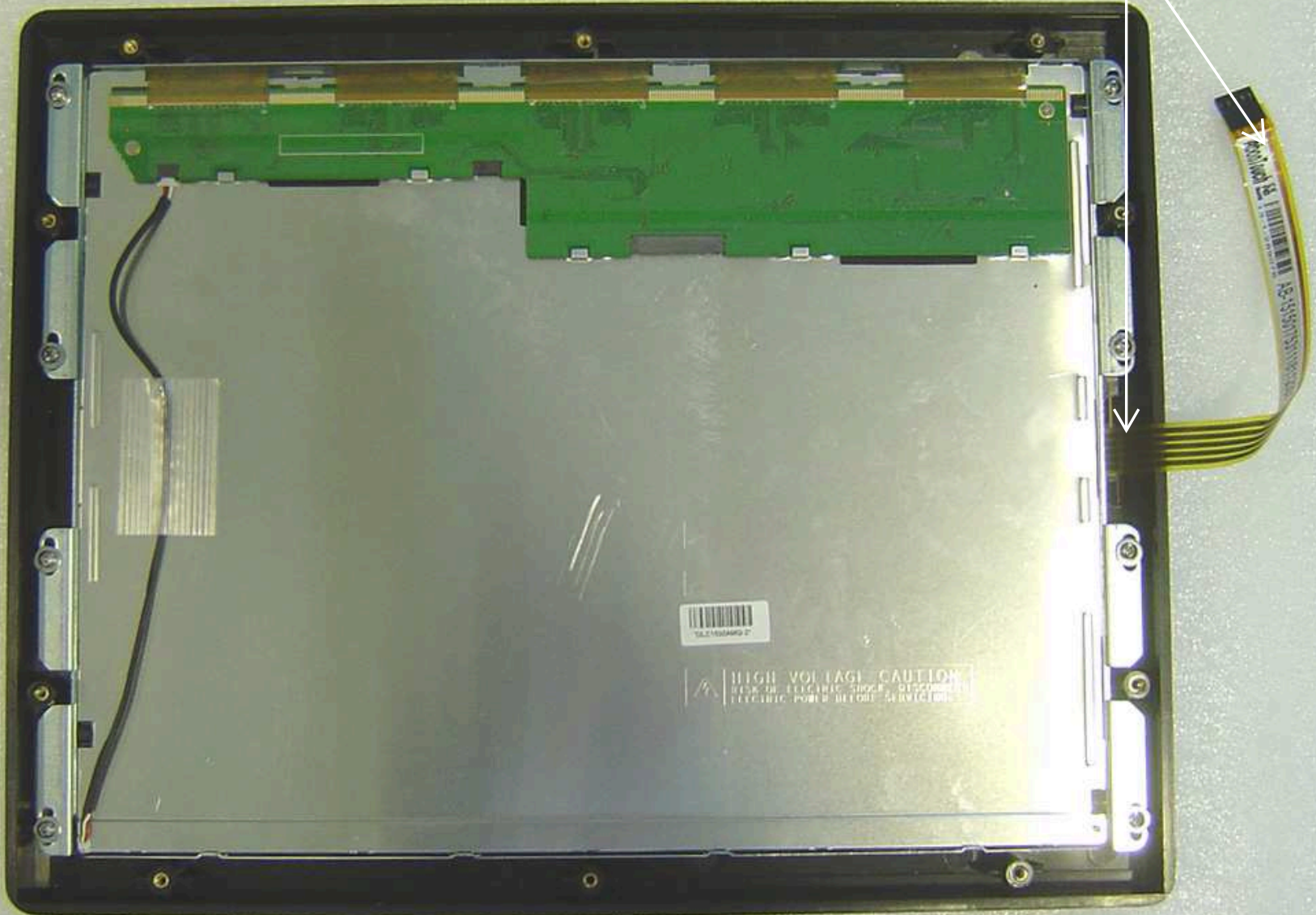

UL2168480 01

HIGH VOLTAGE CAUTION
RISK OF ELECTRIC SHOCK. DISCONNECT
ELECTRIC POWER BEFORE SERVICING.

CONNECT THE TOUCH CABLE, AT THIS POSITION, IN UP PINES

HOLD THE CABLES WITH FLANGE

PASS THE CABLES P/N.- 90114093 AND P/N.- 90114094 THROUGH THE HOLE

CONNECT THE CABLE P/N.- 90114089

CONNECT THE CABLE P/N.- 90114090

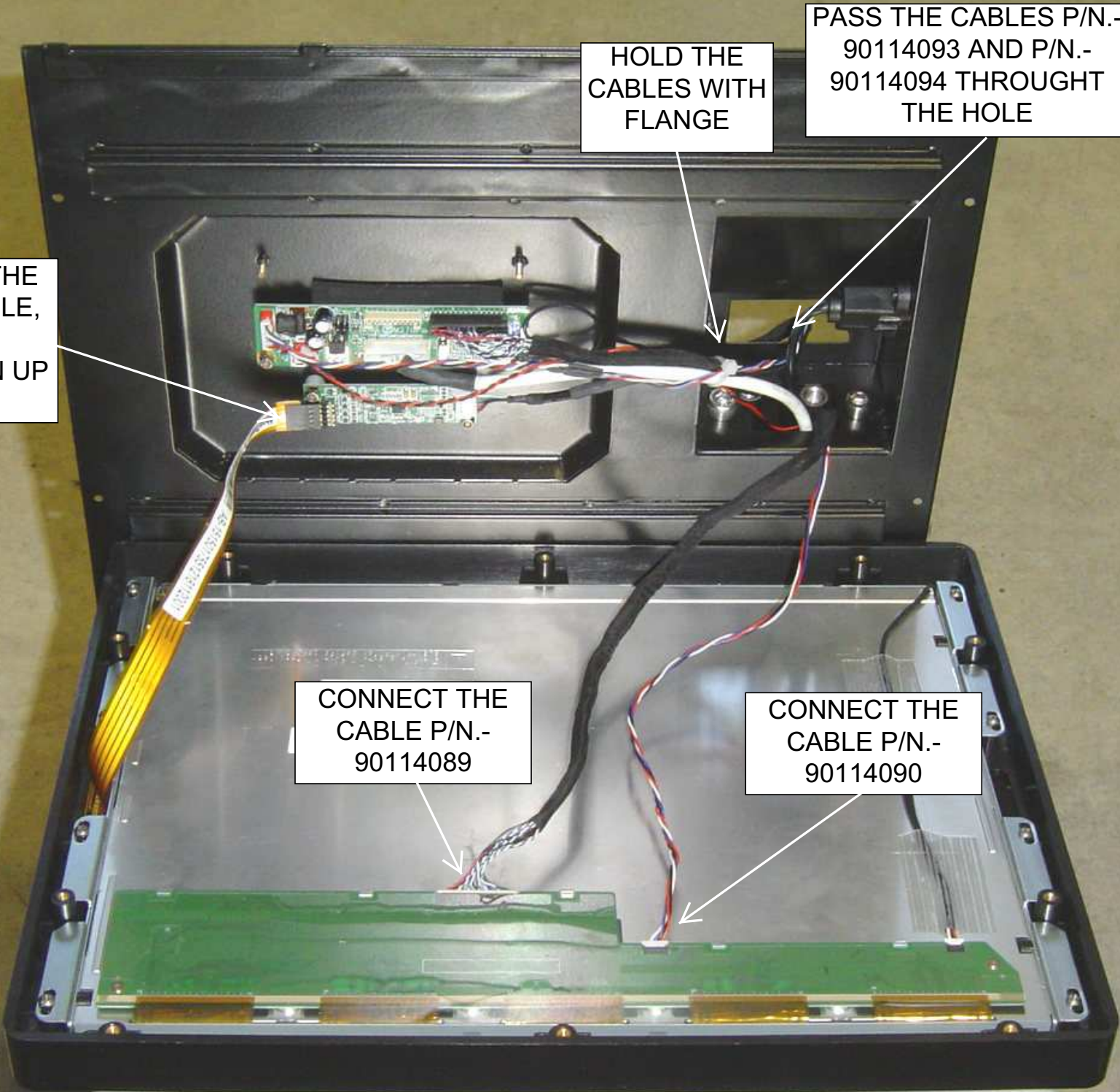

INSERT IN TABS

INSERT THE TOP OF THE MONITOR SUPPORT TO THE TABS AND AFTER HOLD THE SUPPORT WITH 6 SCREWS P/N.-72054017

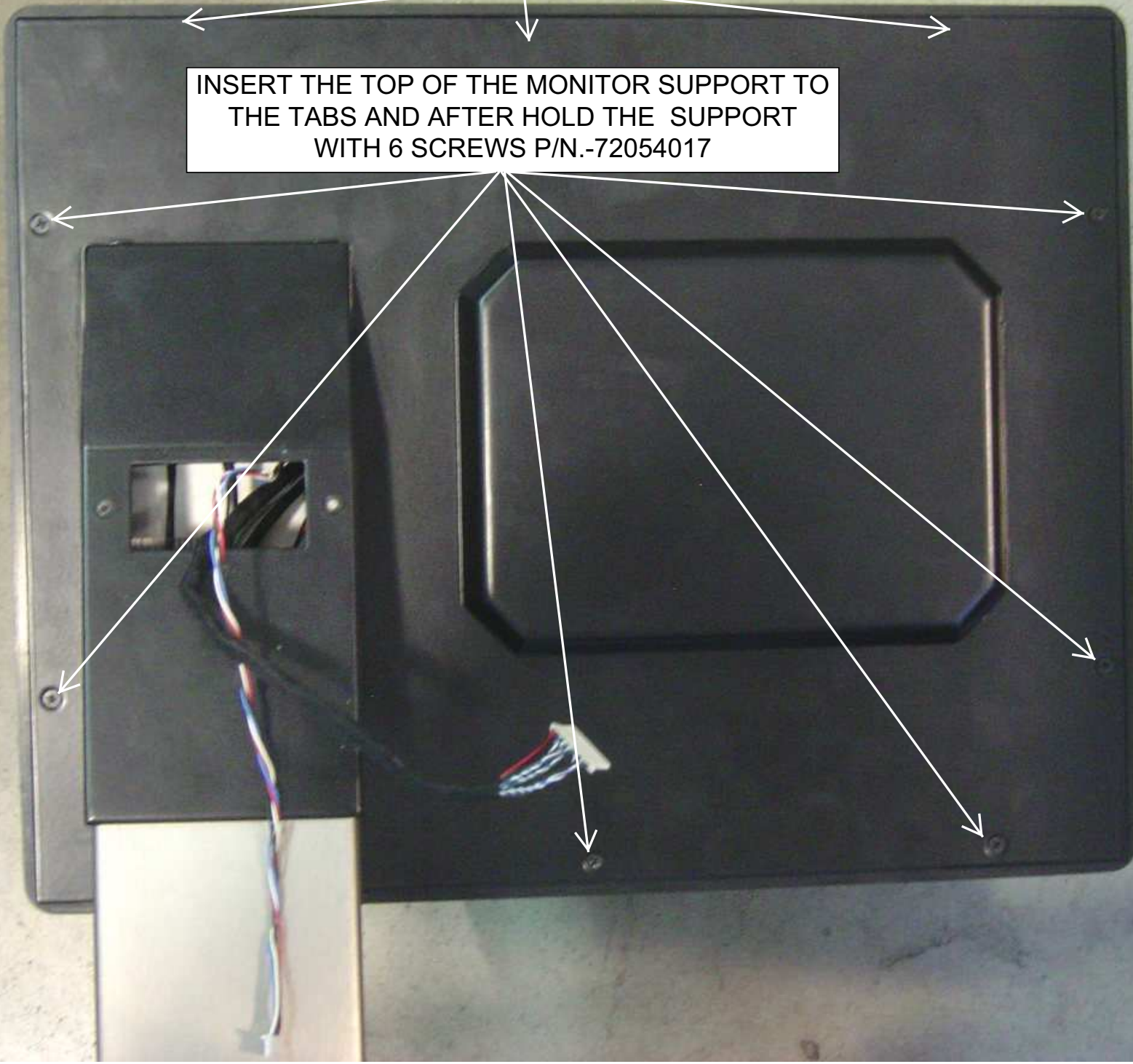

12.- ASSEMBLY SUPPORT BACK MONITOR (COMPONENTS)

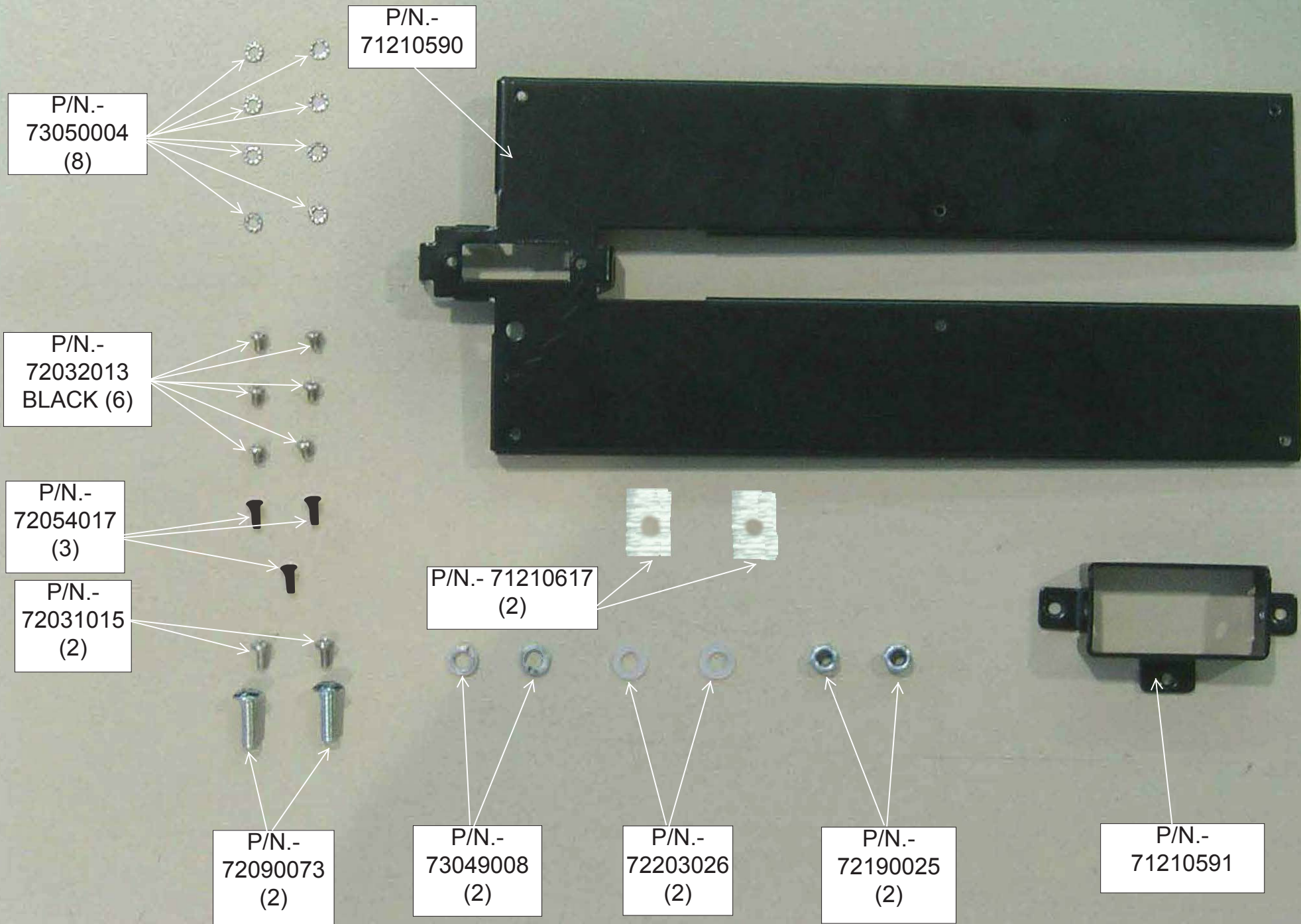

12.- ASSEMBLY SUPPORT BACK MONITOR (COMPONENTS)

P/N.-
71210592

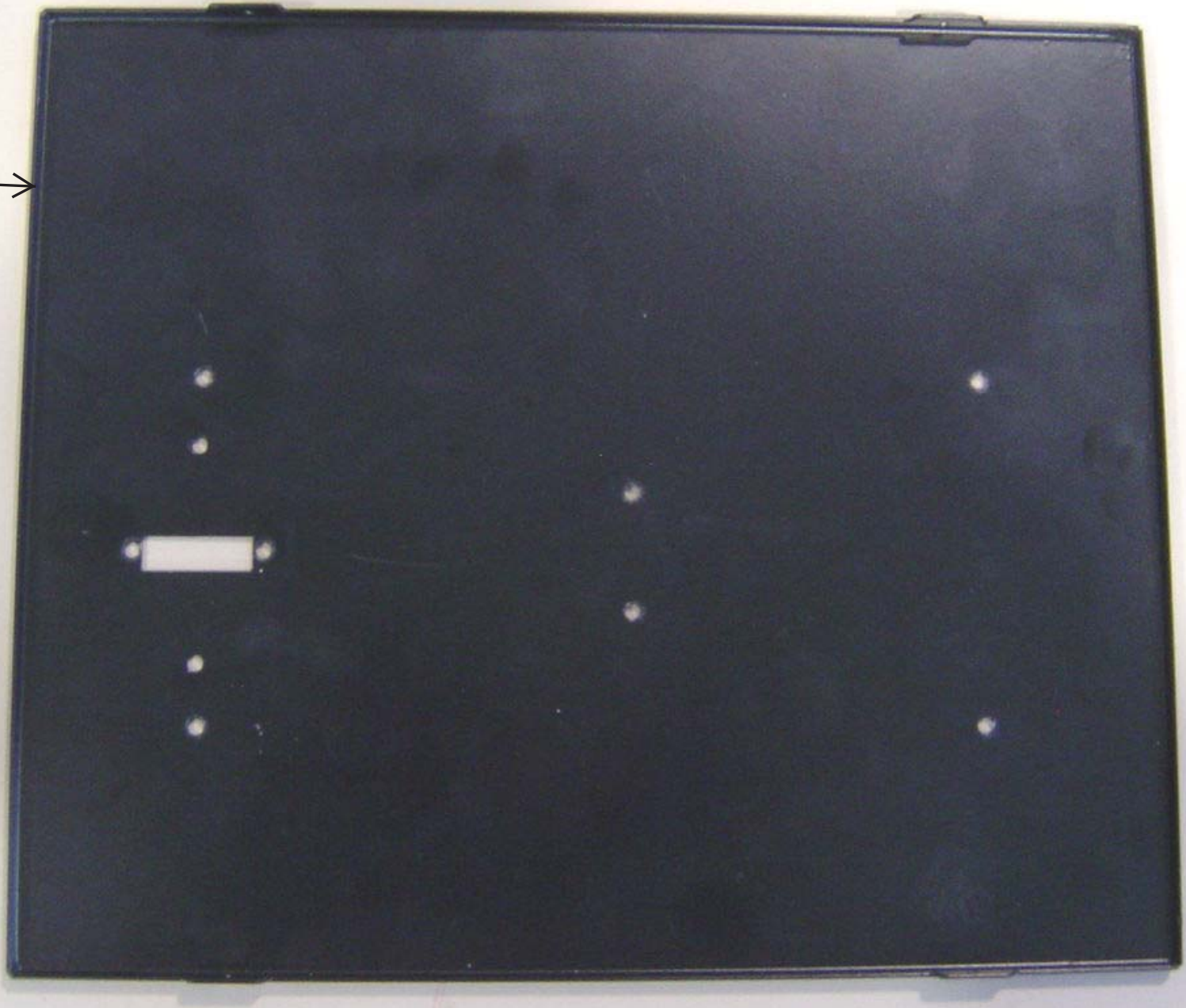

ASSEMBLY THE PIECES P/N.- 71210591 AND P/N.- 71210617 ON
PIECE P/N.- 71210590 AND HOLD WITH SCREWS P/N.- 72090073,
WHASERS P(N.- 73049008 AND 72203026 AND NUTS 72190025
(SEE NEXT PICTURES TO VIEW THE POSITION THIS PIECES)



PIECES P/N.-
71210617

DETAIL OF POSITION OF
PIECES P/N.- 71210617

WHASERS
P/N.-
73049008

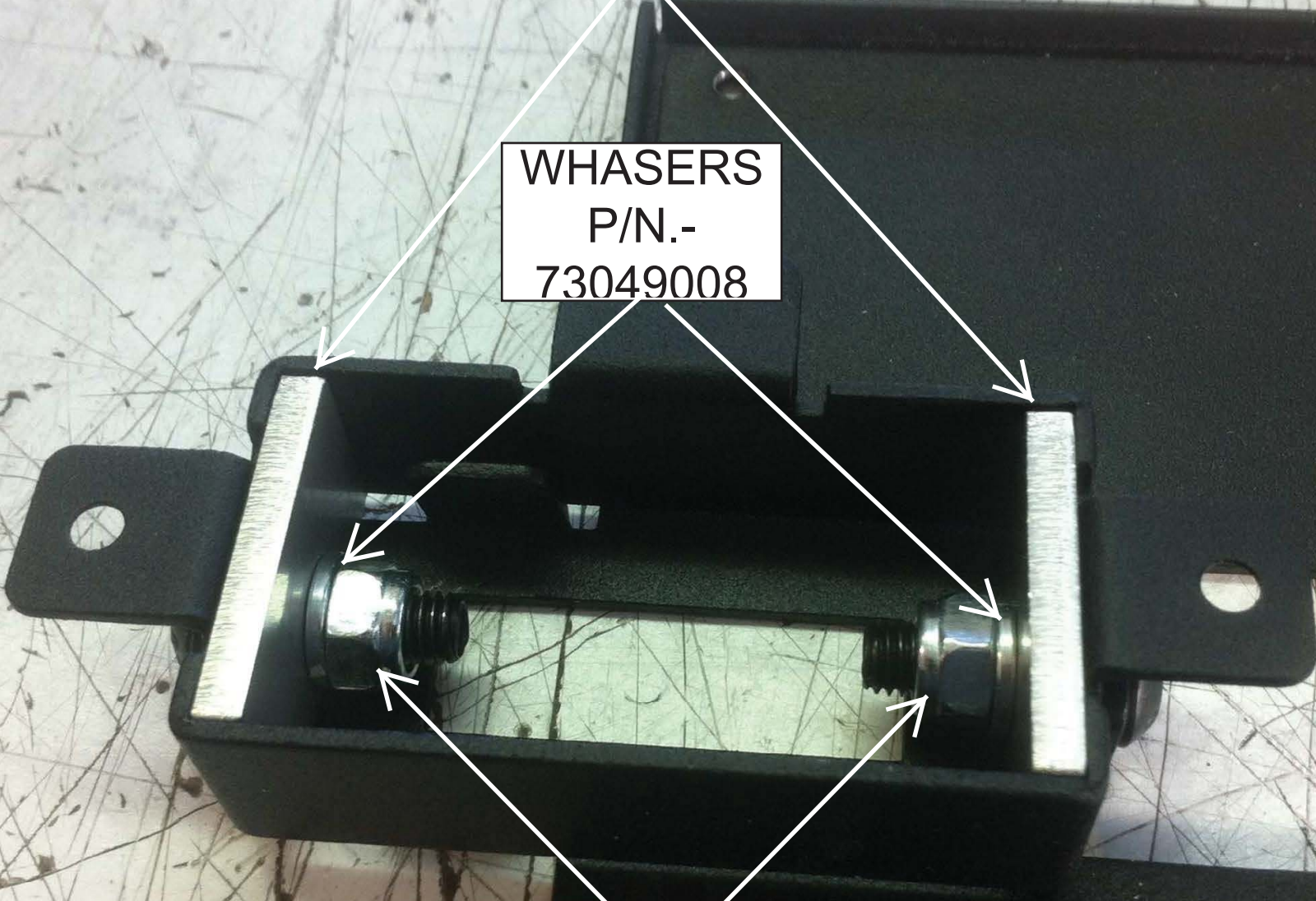

P/N.-
72190025

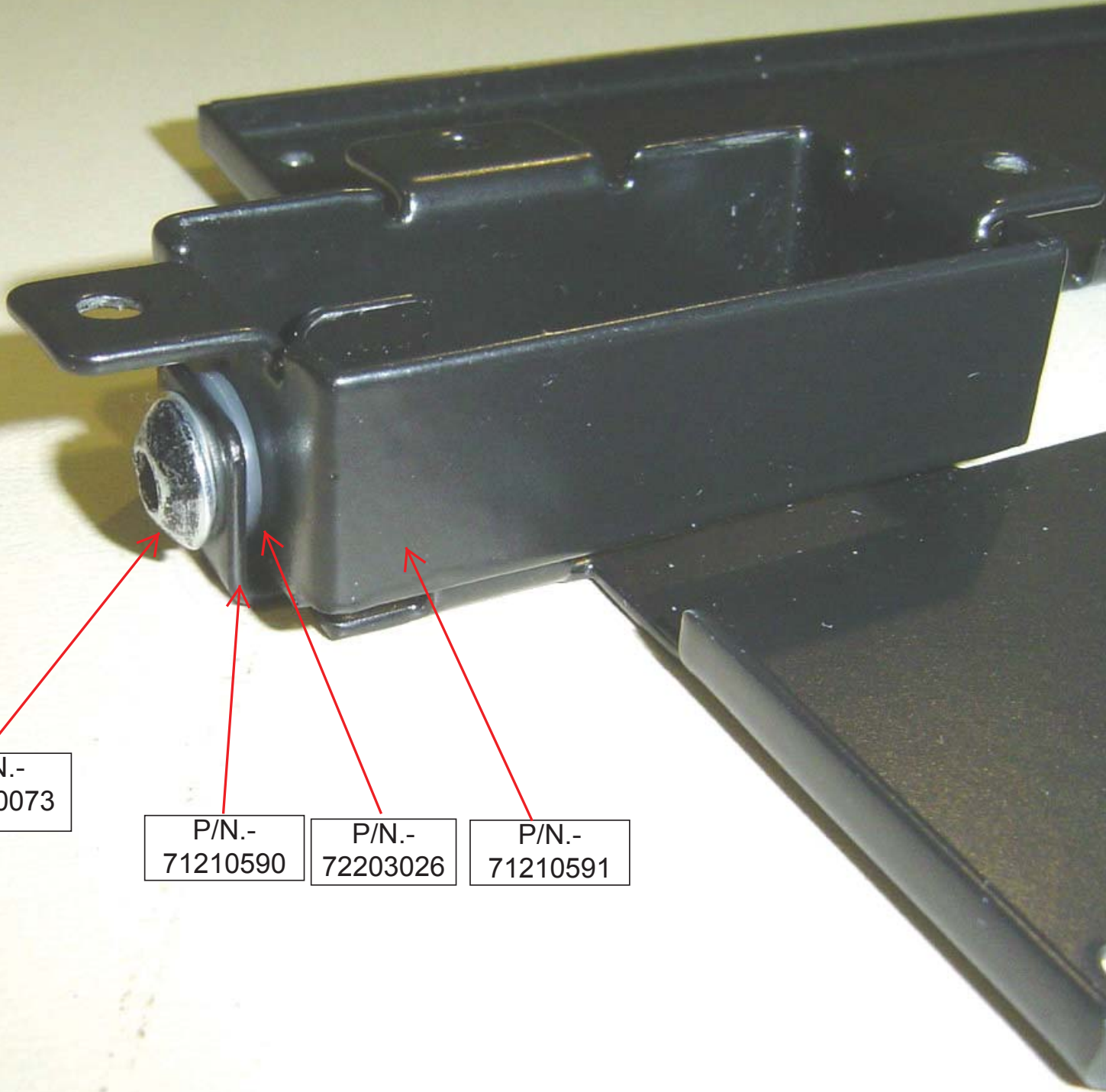

P/N.-
72090073

P/N.-
71210590

P/N.-
72203026

P/N.-
71210591

P/N.-
71210617



P/N.-
71210591



P/N.-
72203026

P/N.-
71210590



P/N.-
72090073

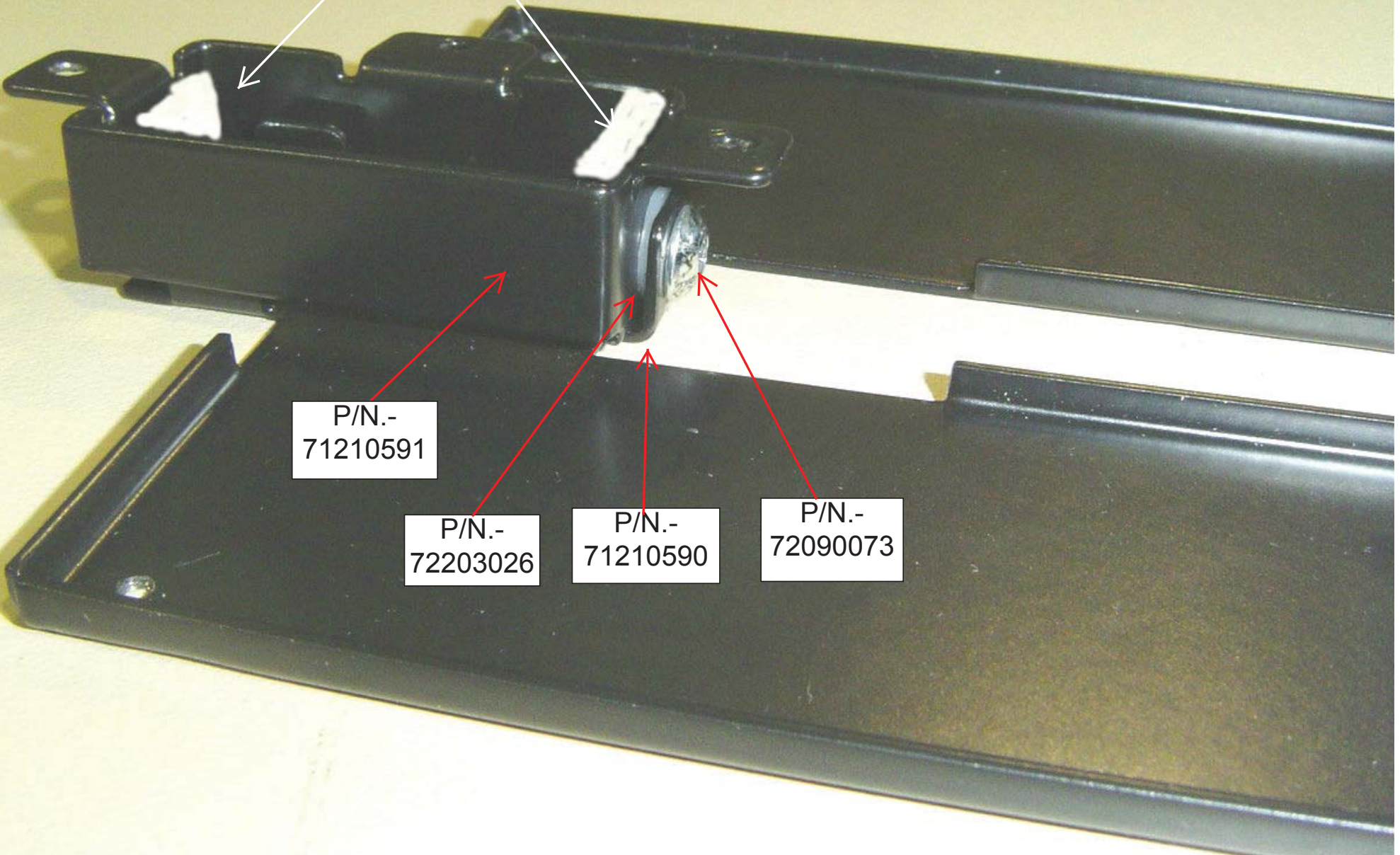

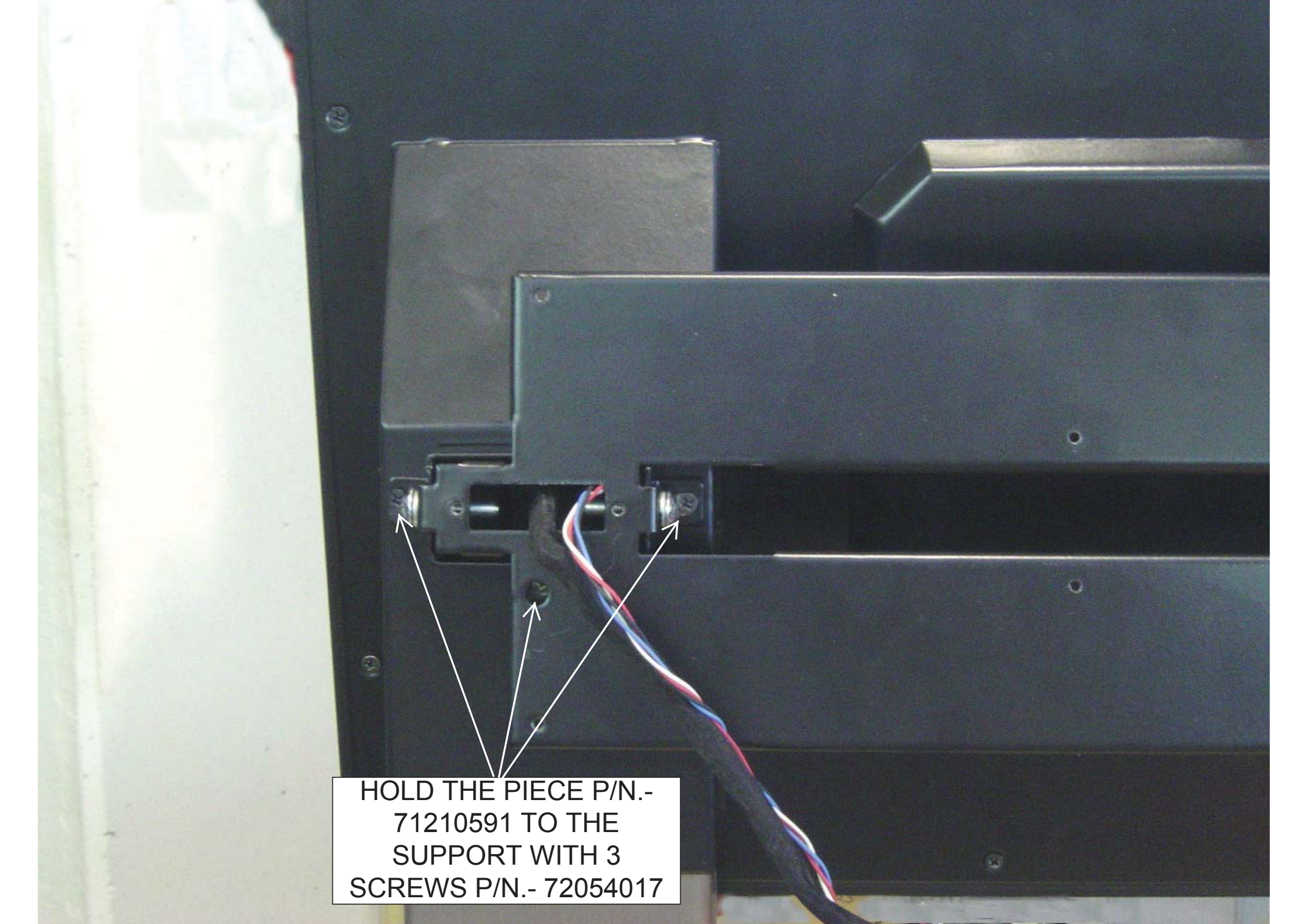

HOLD THE PIECE P/N.-
71210591 TO THE
SUPPORT WITH 3
SCREWS P/N.- 72054017

HOLD THE SUPPORT BACK PANEL P/N.- 71210592 WITH 6 SCREWS P/N.- 72032013 AND 2 SCREWS P/N.- 72031015 PUTTING WHASERS.

6 WHASERS P/N.- 73050004
AND 6 SCREWS P/N.-
72032013 (BLACK)

2 WHASERS
P/N.- 73050004
AND 2
SCREWS P/N.-
72031015

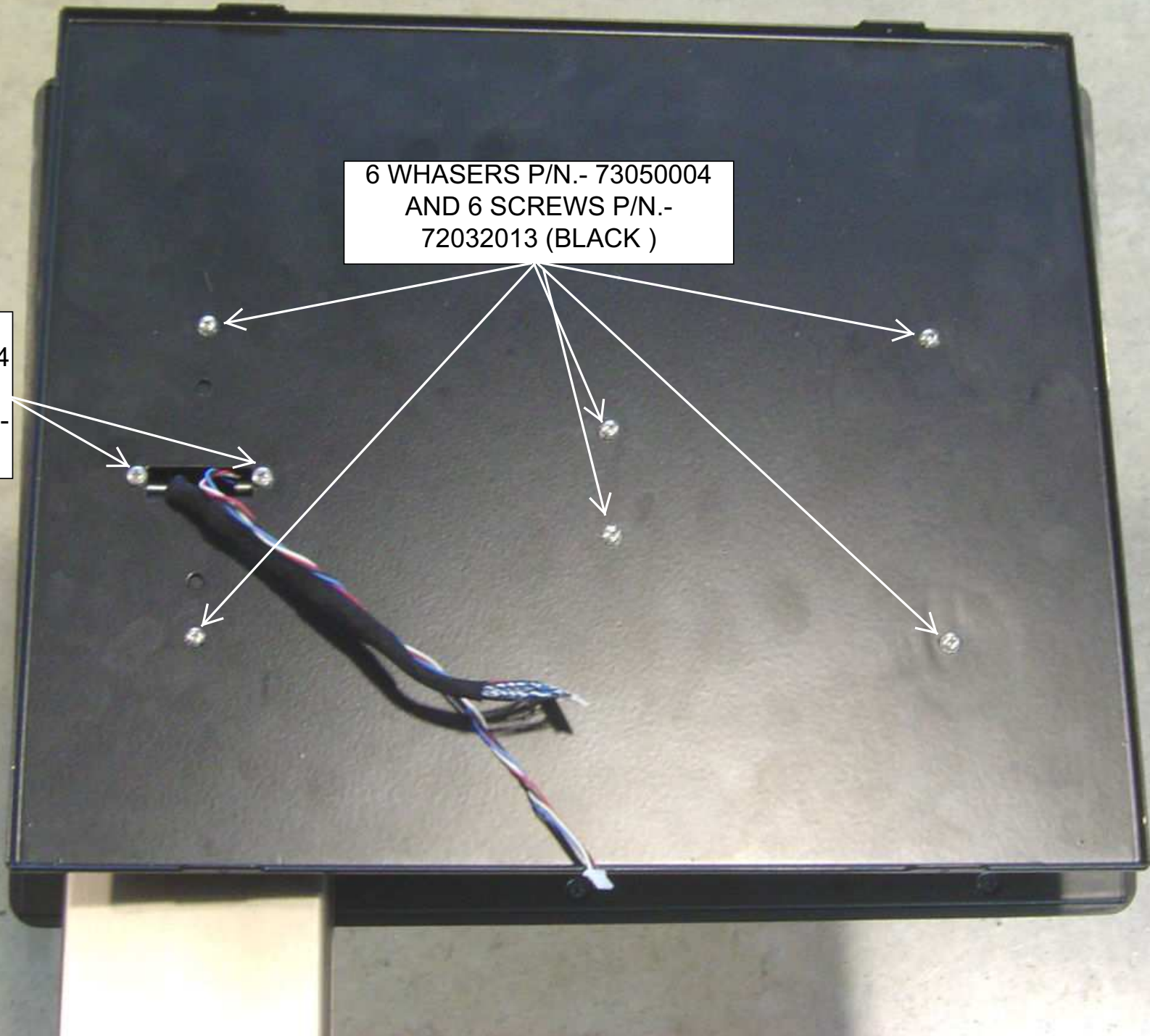

13.- ASSEMBLY AND CONNECT SET BACK MONITOR (COMPONENTS)

P/N.-
19019300

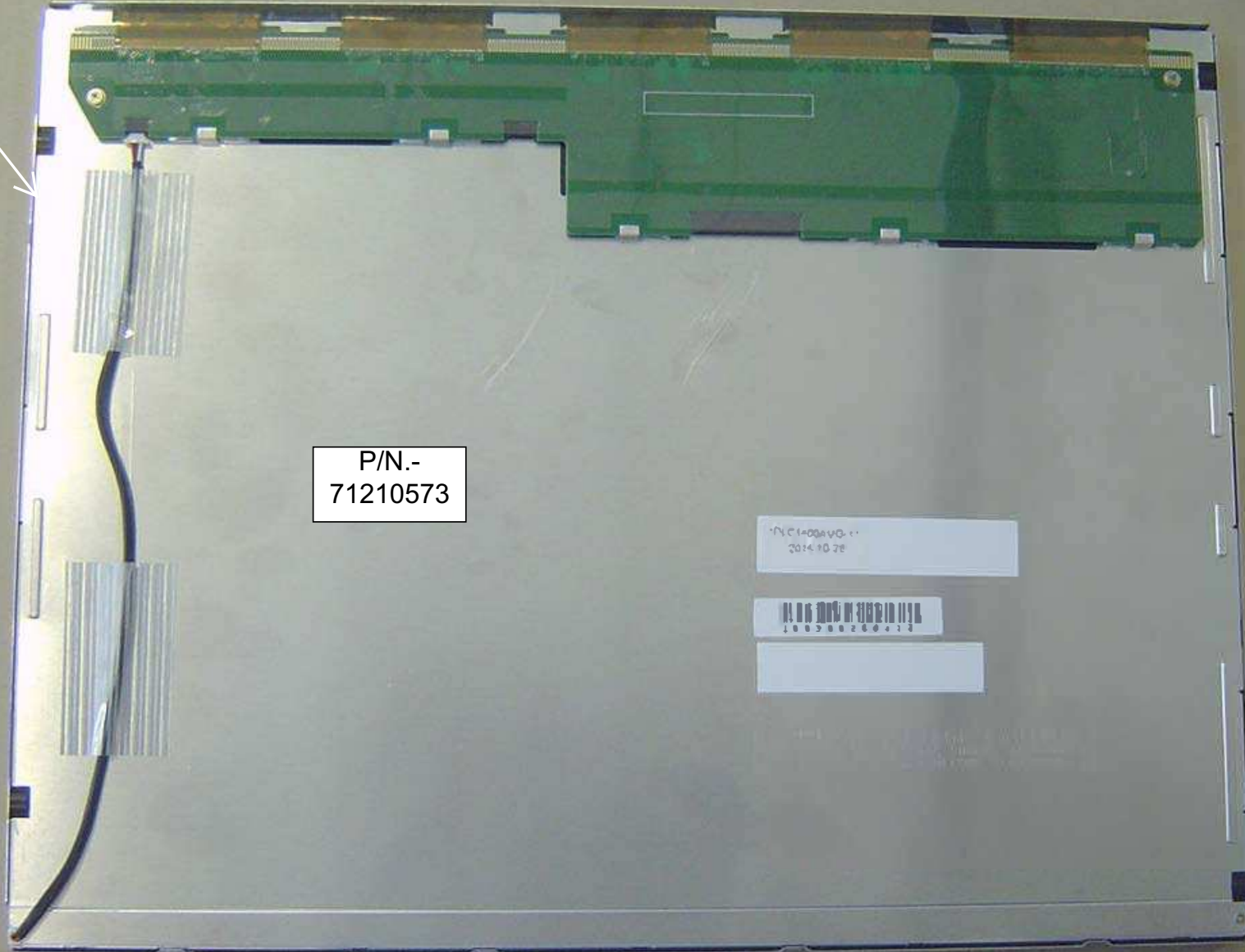

P/N.-
71210573

P/N.-004V0-11
2014.10.26

100500260413

13.- ASSEMBLY AND CONNECT SET BACK MONITOR (COMPONENTS)

P/N.-
71004527

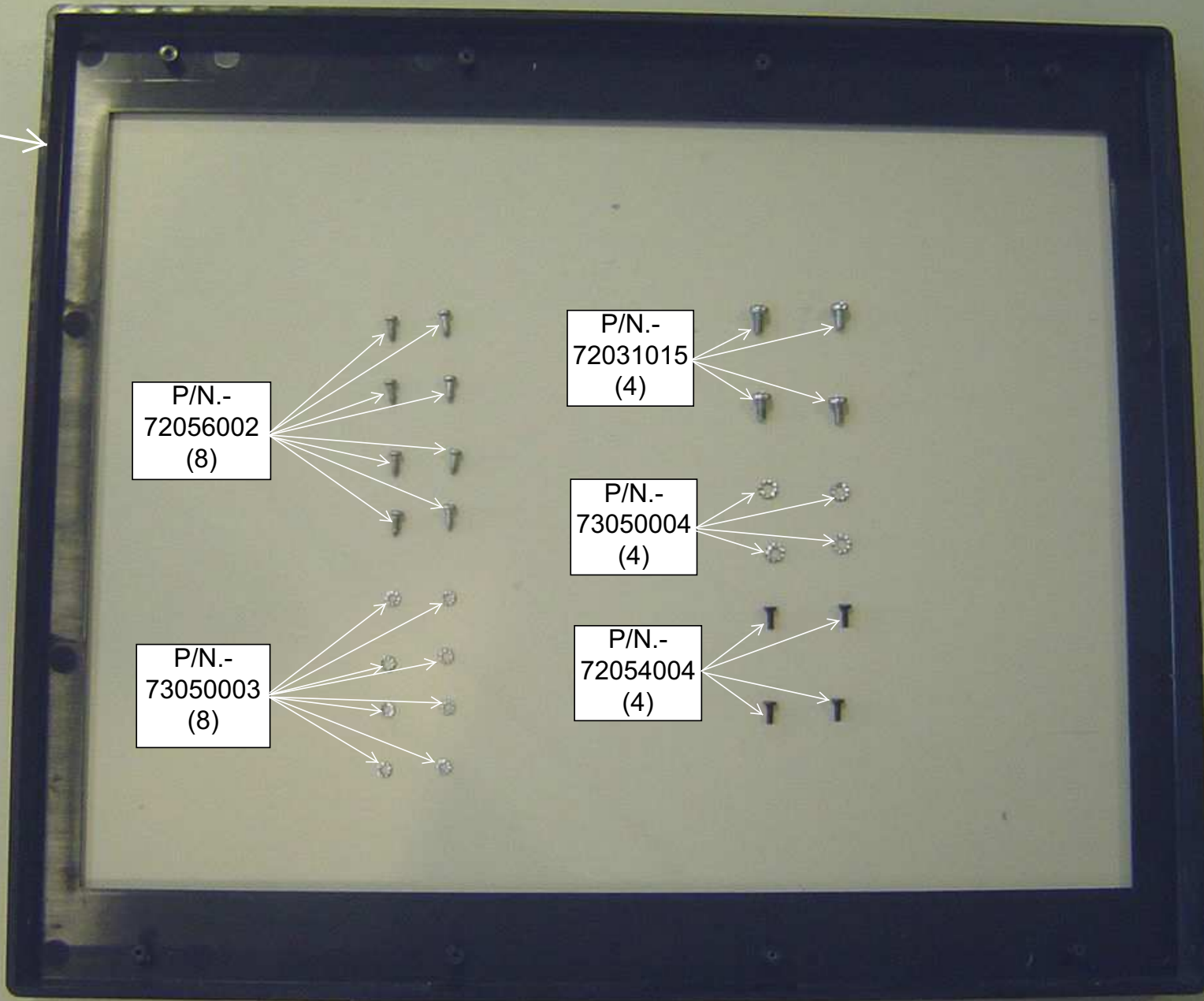

P/N.-
72056002
(8)

P/N.-
72031015
(4)

P/N.-
73050004
(4)

P/N.-
73050003
(8)

P/N.-
72054004
(4)

13.- ASSEMBLY AND CONNECT SET BACK MONITOR (COMPONENTS)

P/N.-
71210573



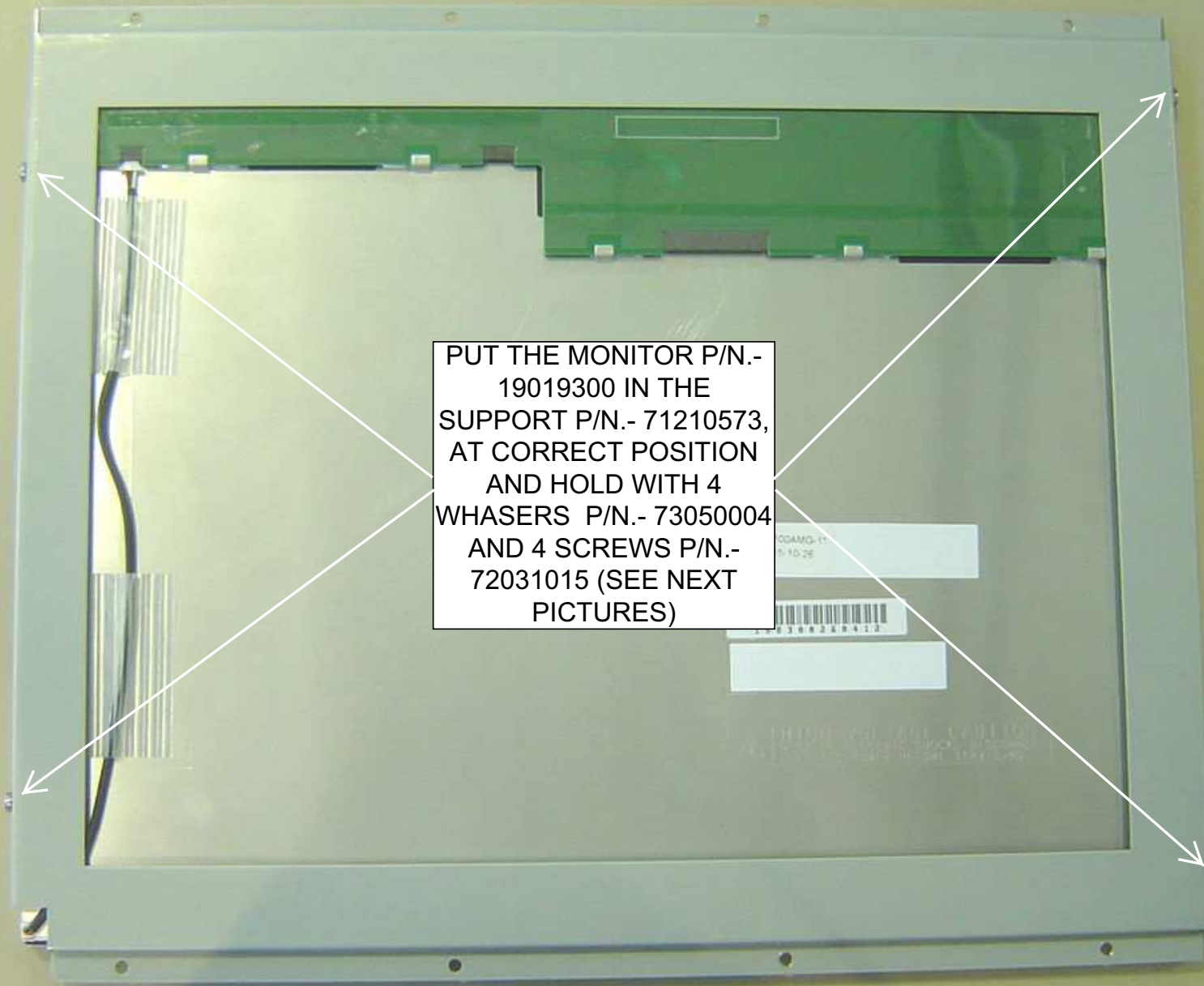

PUT THE MONITOR P/N.-
19019300 IN THE
SUPPORT P/N.- 71210573,
AT CORRECT POSITION
AND HOLD WITH 4
WHASERS P/N.- 73050004
AND 4 SCREWS P/N.-
72031015 (SEE NEXT
PICTURES)

00AMG-11
7-10-26



71210573

19019300

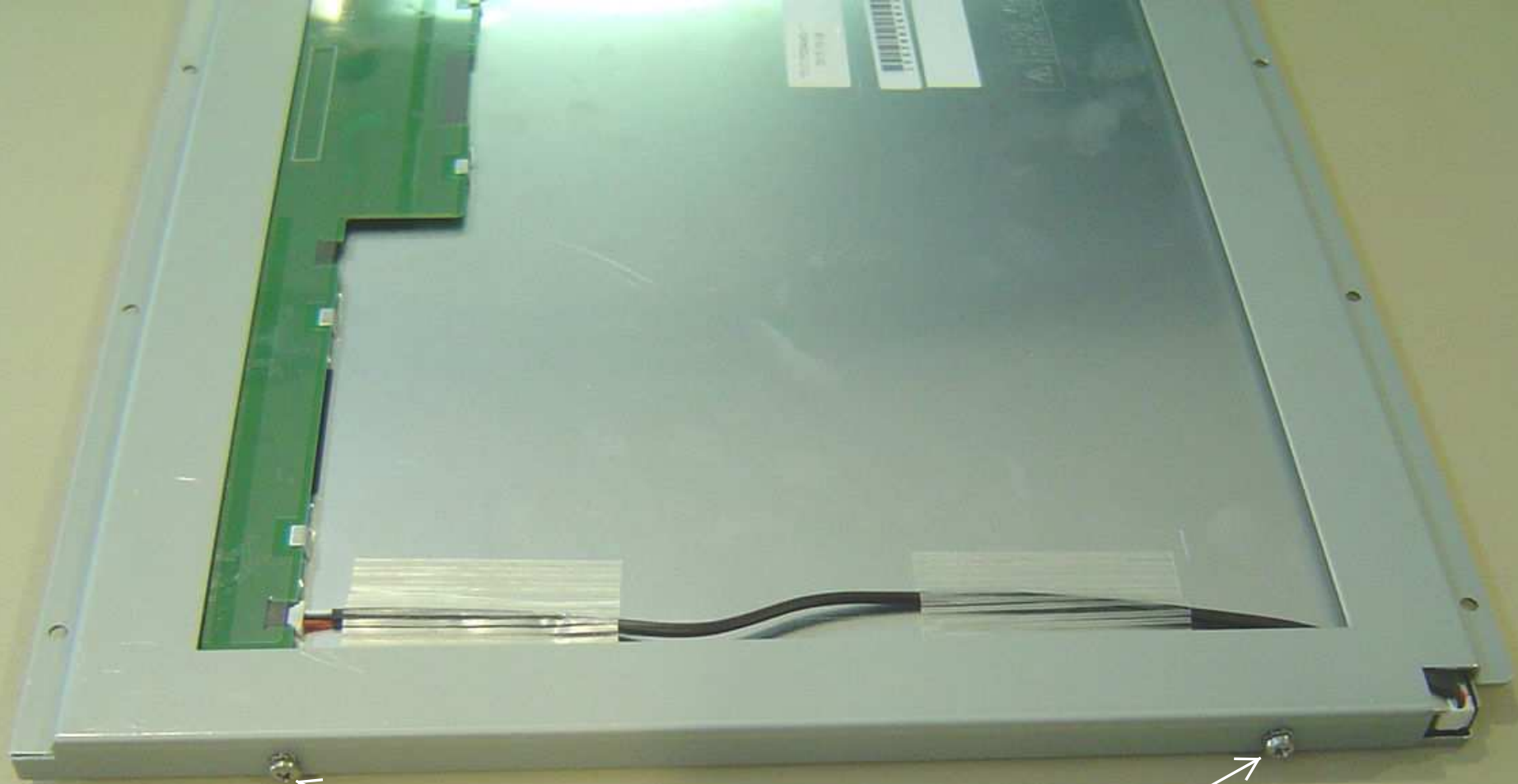

WHASERS P/N.-
73050004 AND
SCREWS P/N.-
72031015



WHASERS P/N.-
73050004 AND
SCREWS P/N.-
72031015

PUTTING THE SUPPORT CENTER, TO AVOID SEE THE EDGE SILVER
(SEE NEXT PICTURE)

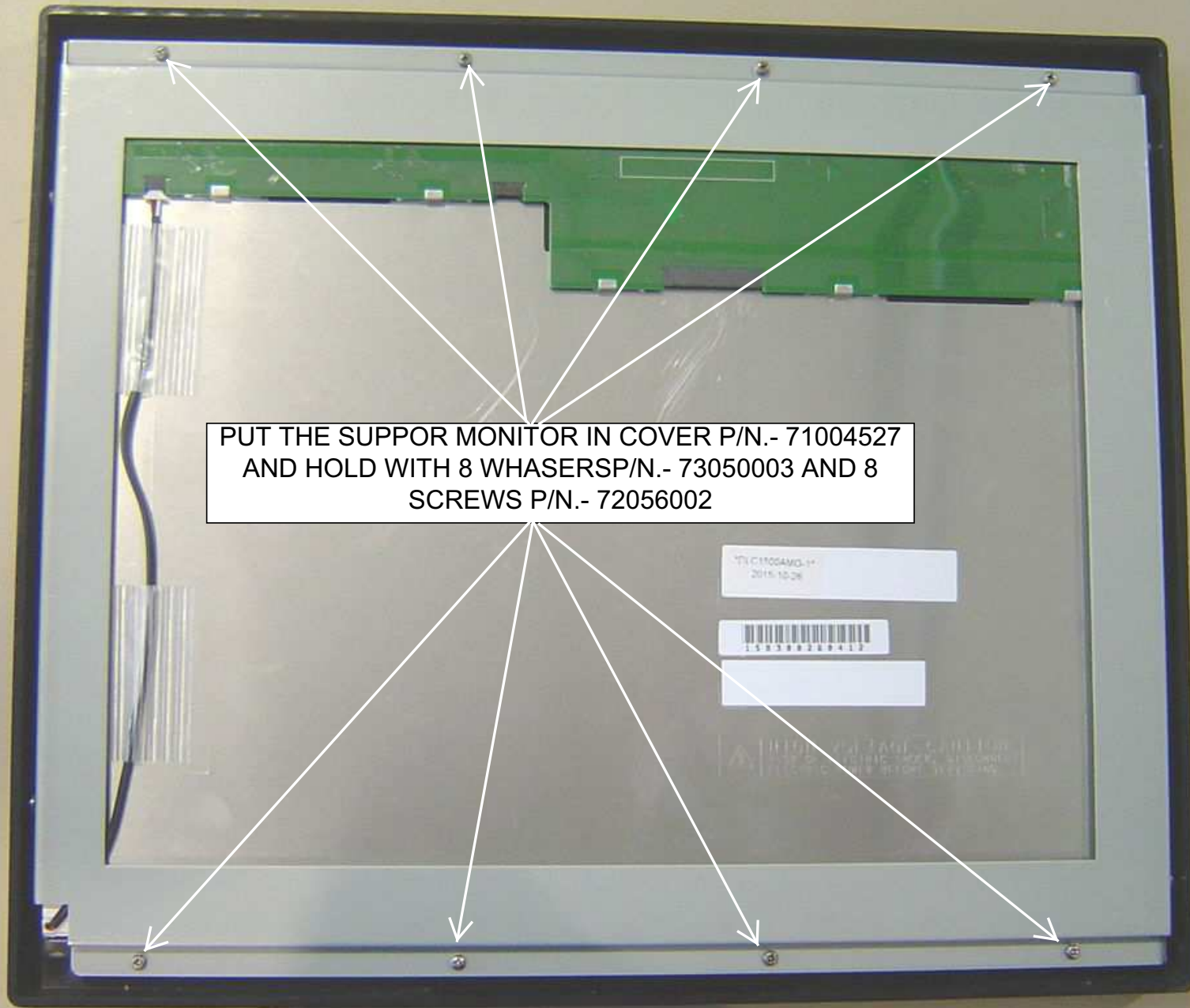

PUT THE SUPPOR MONITOR IN COVER P/N.- 71004527
AND HOLD WITH 8 WHASERSP/N.- 73050003 AND 8
SCREWS P/N.- 72056002

TO PREVENT SEE THE
EDGE SILVER

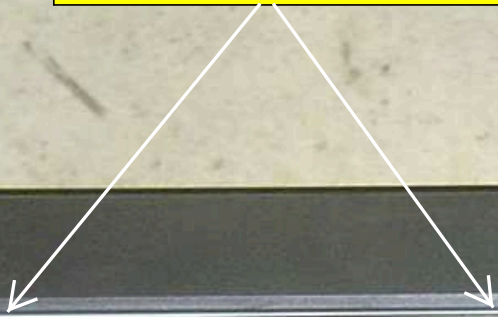



CONNECT THE
CABLES P/N.-
90114093 AND P/N.-
90114094 TO BACK
MONITOR

ASSEMBLY THE HOUSING
MONITOR AT THE
SUPPORT AND HOLD WITH
4 SCREWS P/N.- 72054004
(SEE NEXT PICTURE FOR
BOTTOM PART)

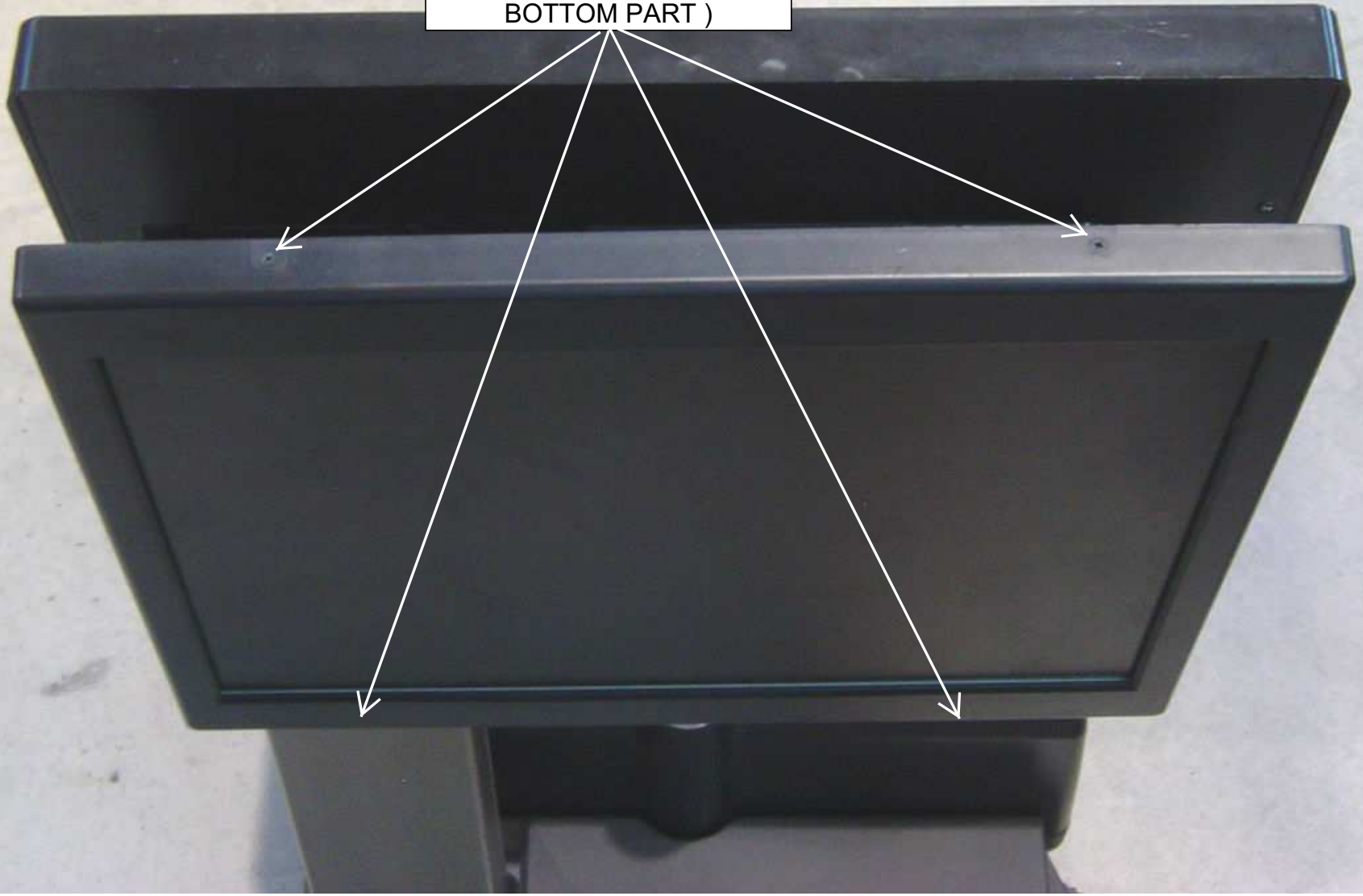



SCREWS P/N.-
72054004

14.- FINISH (COMPONENTS)

PLIERS FOR SEALING



P/N.- 70000868



P/N.- 70000761



P/N.- 70010374



P/N.- 70010068A



PLASTIC SEAL P/N.- 79000016



SEAL CABLE P/N.- 79500137 (100mm)

P/N.- 71004542 (THIS PIECE YOU MUST SEND WITH THE SCALE, NOT ASSEMBLY)



Man.-G.EPELSA S.L. Cert.nº T8471 Serial nº 888686
C/Punto Net, 3-28805 Alcalá de Henares-Madrid (Spain)
MODEL:PCSK 110V/240V 50/60Hz Imax=1,5A
Max15kg Min100g III   M16 0122
T=-9,995kg e=5g

PASTE THE NAME PLATE P/N.-
70010374 AND PASTE UP THE
PROTECTOR P/N.- 70000868

PUT THE CABLE SEAL P/N.-
79500137 AND SEAL P/N.-
79000016, USING PLIERS
FOR SEALING, AFTER
CHECK THE SCALE



PUT THE LABEL ROLL P/N.-
70010068A AS SHOW IN
THE DRAWING

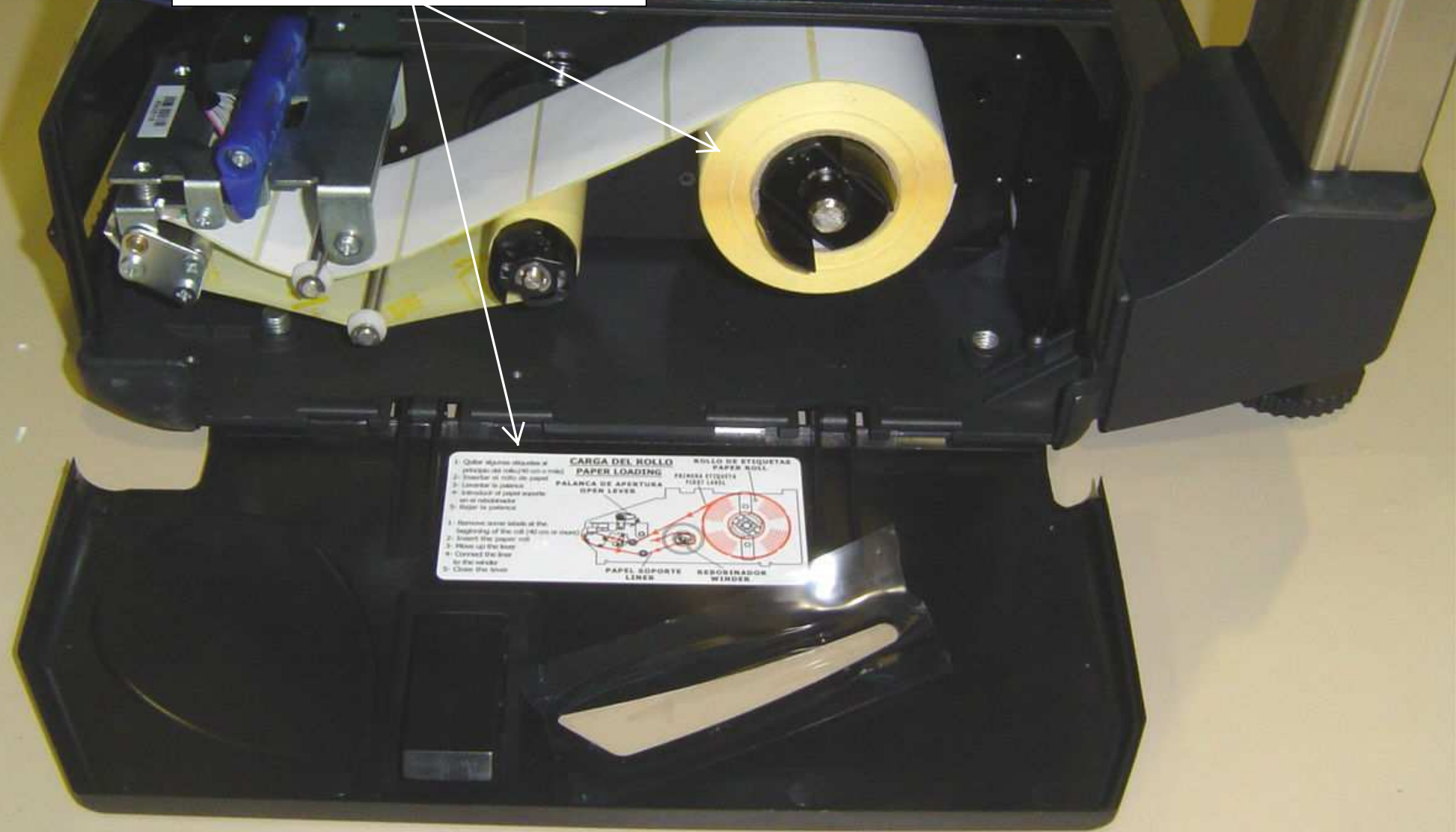



AFTER VERIFY
THE SCALE
PASTE THE
LABEL P/N.-
70000761



HOLD THE
CABLES
WITH
CELOPHAN
TO COLUMN,
FOR DON'T
GO INSIDE