

ASSEMBLY P/N.- X13986035 20-PC I 15" IMP-COLUMNA



**GUIDELINE ASSEMBLY P/N.- X13986035 20-PC I 15"
IMP-COLUMNNA**

1. ASSEMBLY BASE AND POWER ENTRY
2. ASSEMBLY POWER SUPPLIES AND SWITCH BOARD
3. ASSEMBLY SET LOAD CELL
4. ASSEMBLY PICO ITX BOARD AND CONNECTIONS BADGE
5. CONNECT CABLES
6. ASSEMBLY COLUMN
7. ASSEMBLY COVER
8. ASSEMBLY UP CROSS AND PUT PAN SCALE
9. ASSEMBLY SUPPORT OF MONITORS
- 10.ASSEMBLY 15" FRONT MONITOR
- 11.ASSEMBLY SUPPORT BACK MONITOR
- 12.ASSEMBLY AND CONNECT SET BACK MONITOR
- 13.ASSEMBLY AND CONNECT SET PRINTER
- 14.CONNECT FINISH

1.- ASSEMBLY BASE AND POWER ENTRY (COMPONENTS)

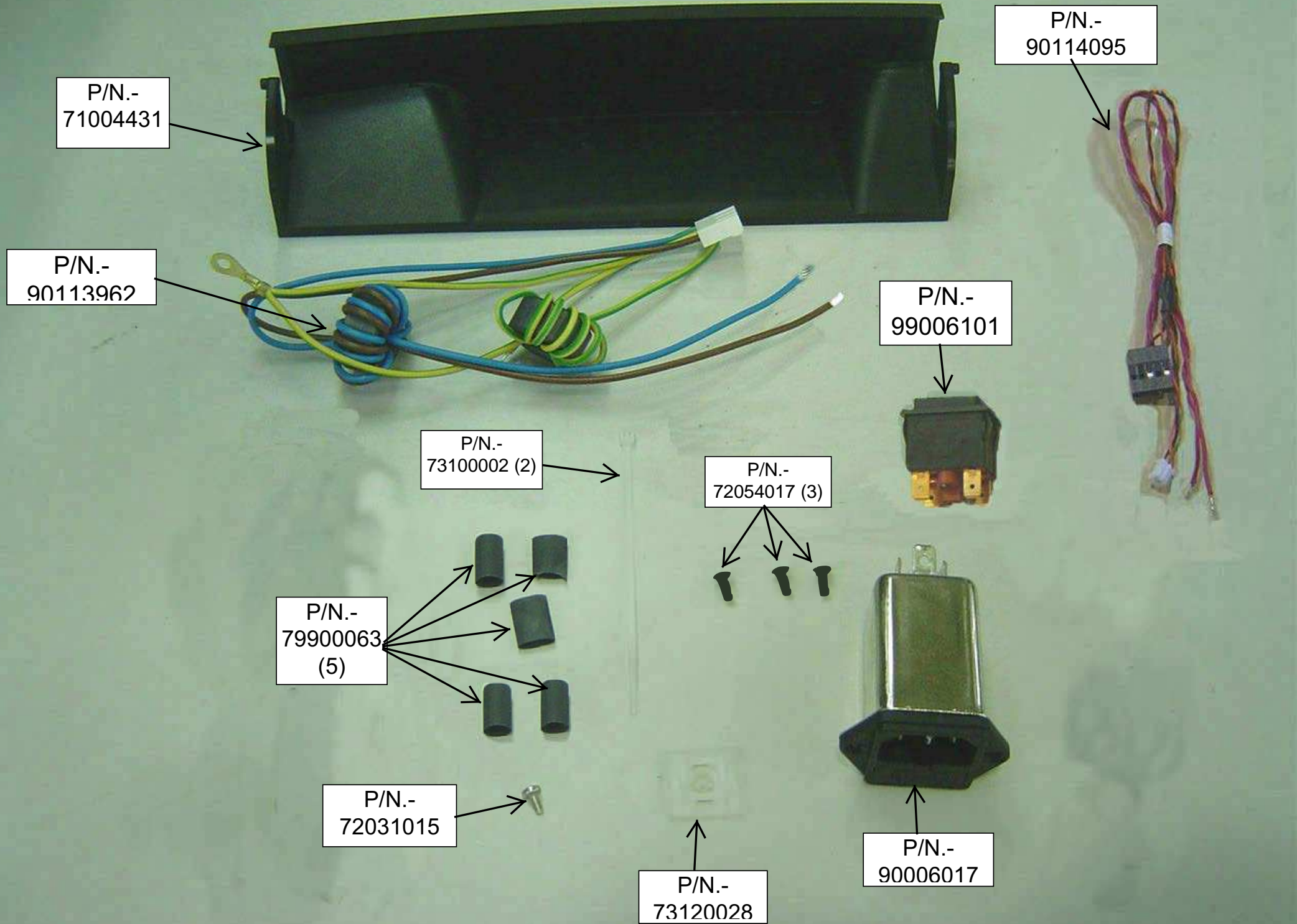

1.- ASSEMBLY BASE AND POWER ENTRY (COMPONENTS)

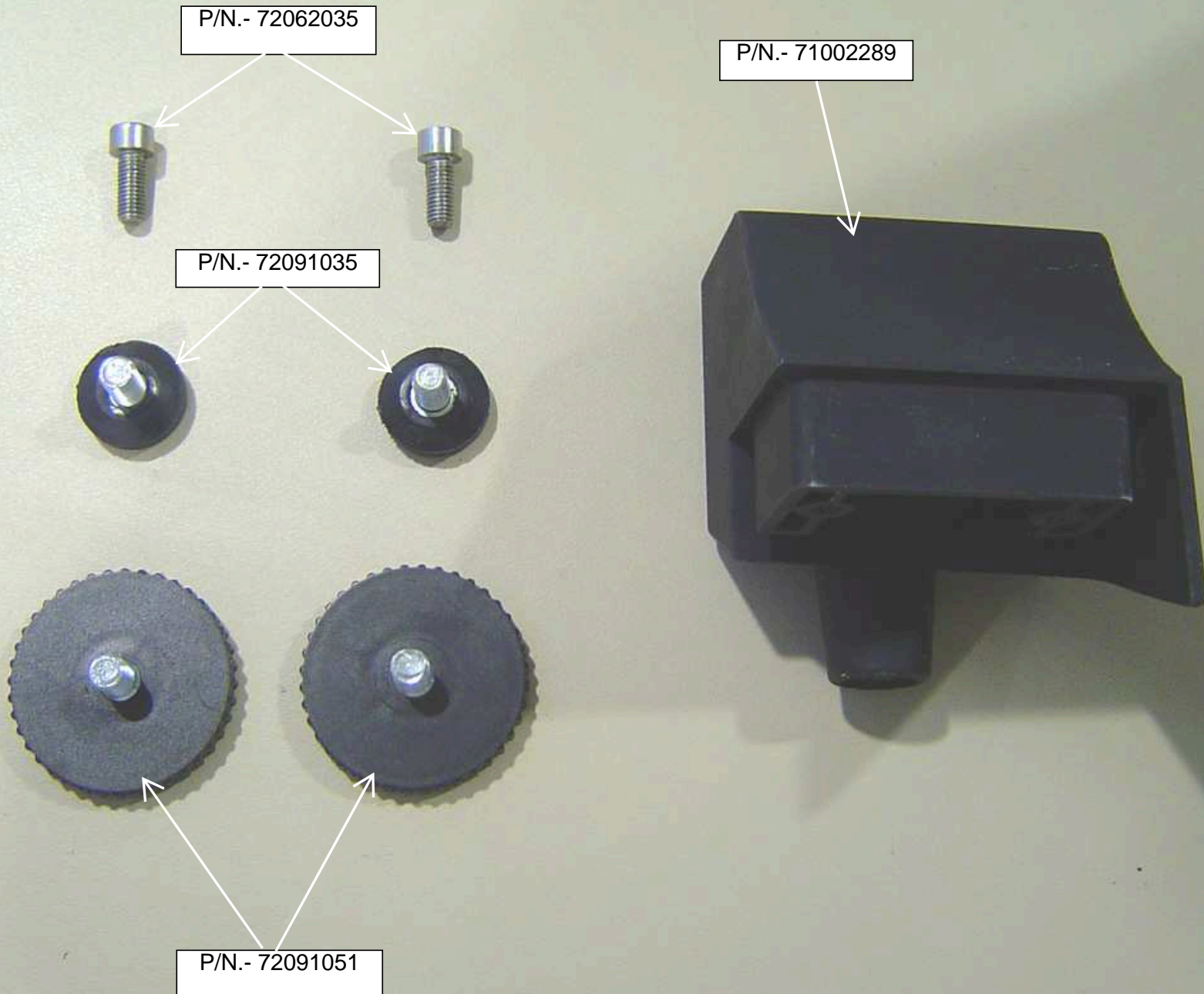

1.- ASSEMBLY BASE AND POWER ENTRY (COMPONENTS)

P/N.- 70000456

P/N.- 70000546

P/N.- 70010205



FUSE 3A

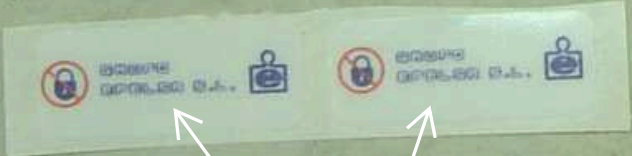

P/N.- 70010155 (2)

SOLDER CABLE P/N.- 90114095
PUTTING SHRINK P/N.-
79900063

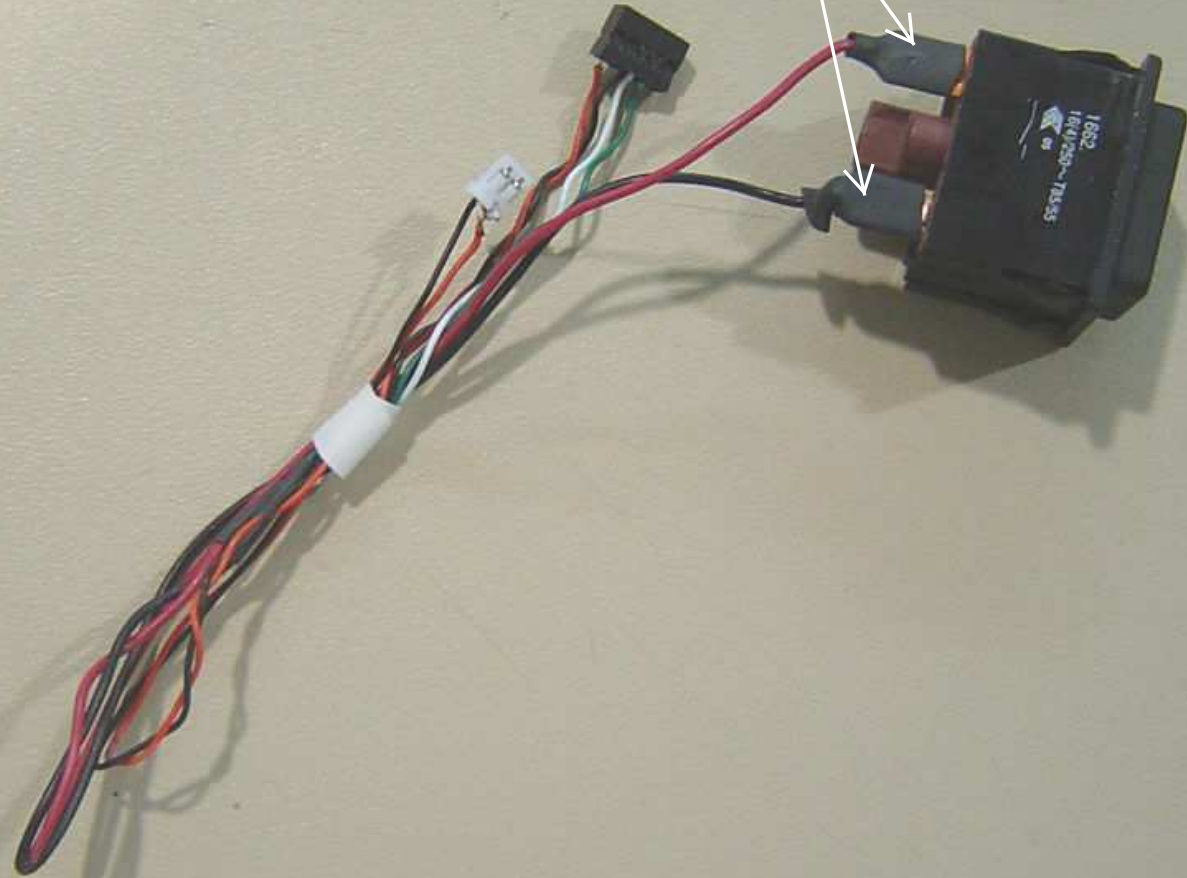

SOLDER THE CABLE P/N.-
90113962 PUTTING SHRINK P/N.-
79900063

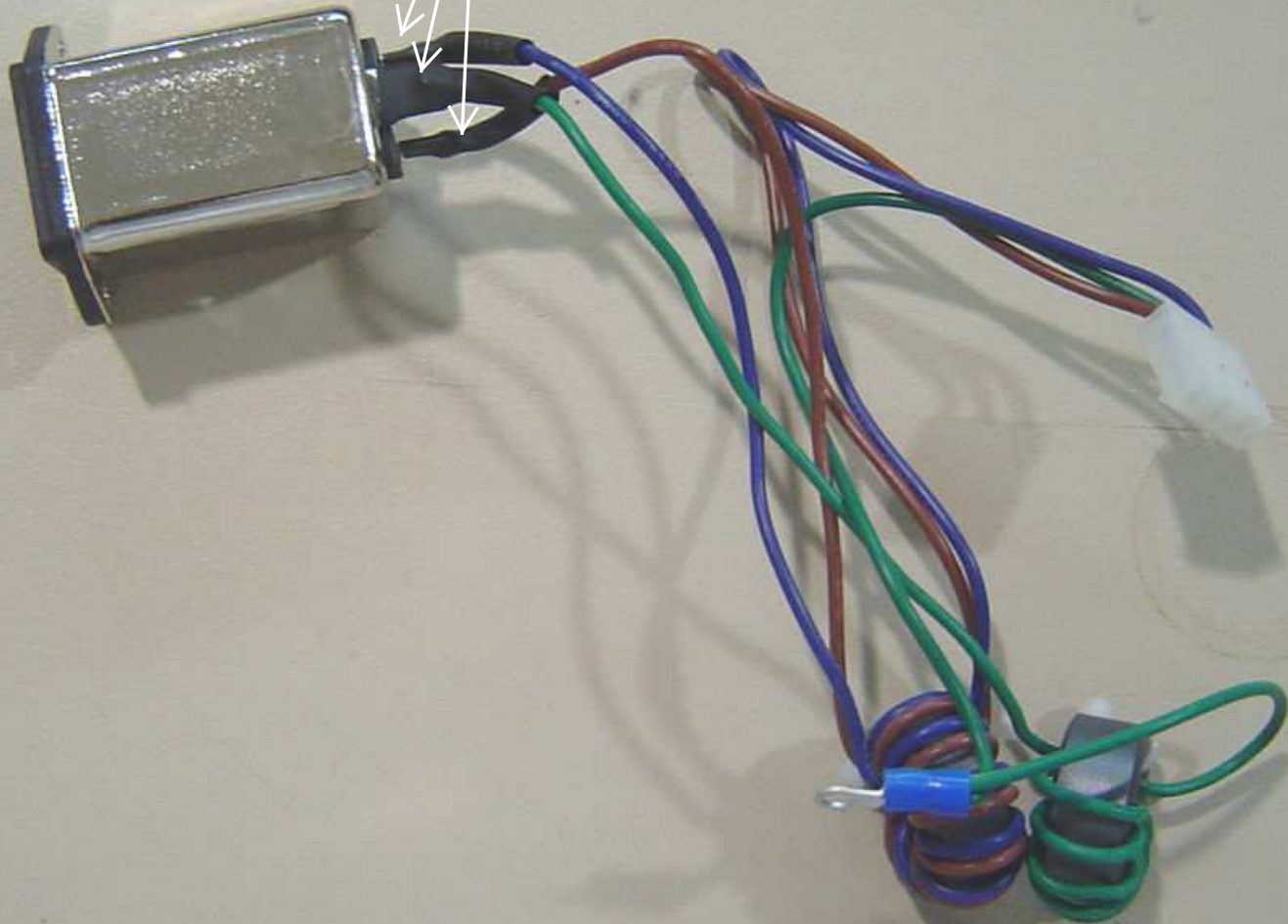

P/N.- 71002288

P/N.-
71002289

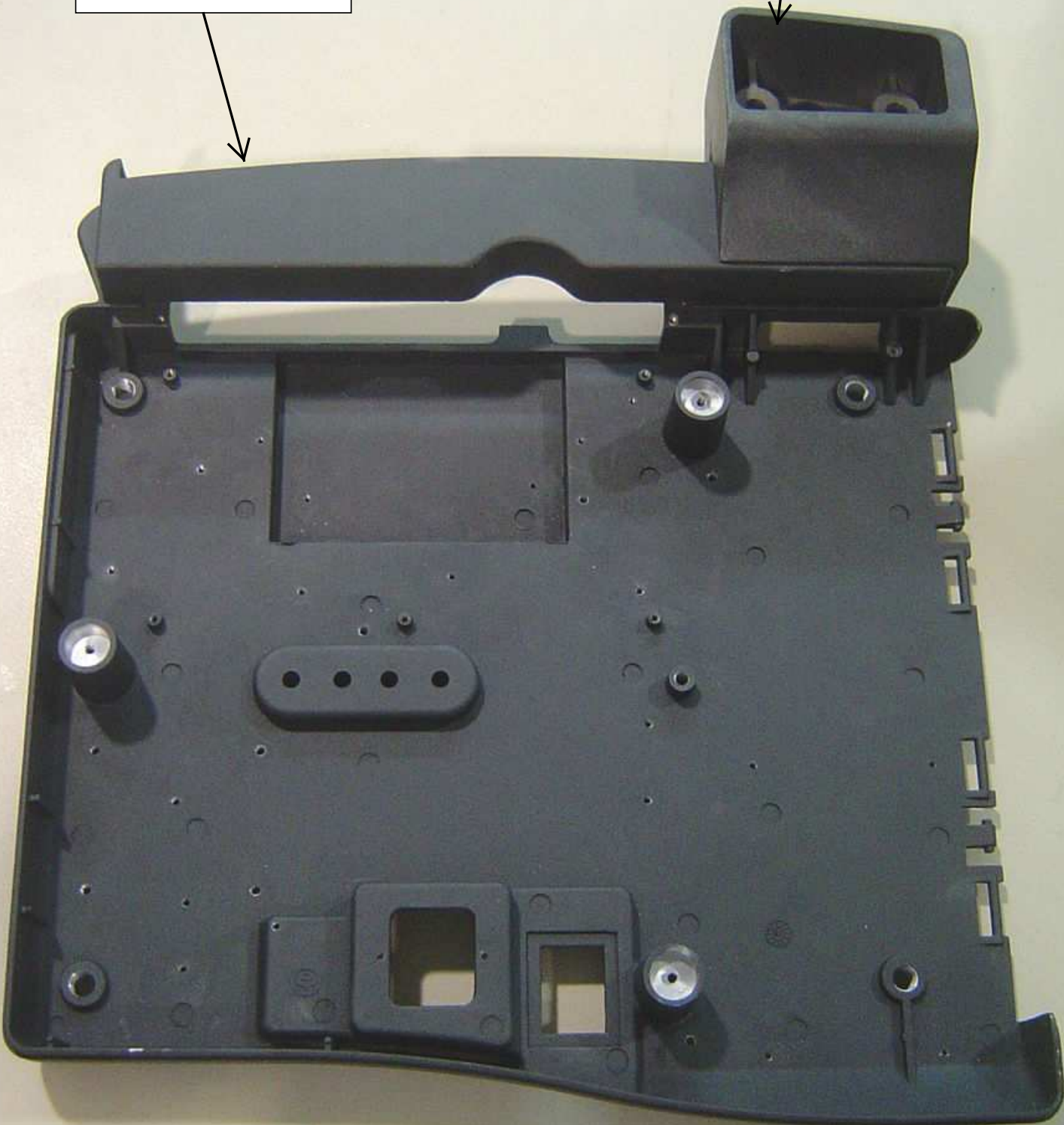

ASSEMBLY THE
PIECE P/N.- 71004379

TIGHTEN THE
FEET P/N.-
72091051

TIGHTEN THE
FEET P/N.-
72091035

PASTE THE
STICK P/N.-
70010205

P/N.-
90006017

FUSE 3A

ASSEMBLY THE
SET ON / OFF
PUSH P/N.-
99006101

PASS THE FERRITES AND
CABLES, OF THE SET
POWER INPUT, THROUGH
THE HOLE AND HOLD
WITH SCREWS P/N.-
72054017

TIGHTEN SCREWS P/N.-
72062035 WITH A
REGULATED TOOL TO A
TIGHTENING TORQUE 11
Nm

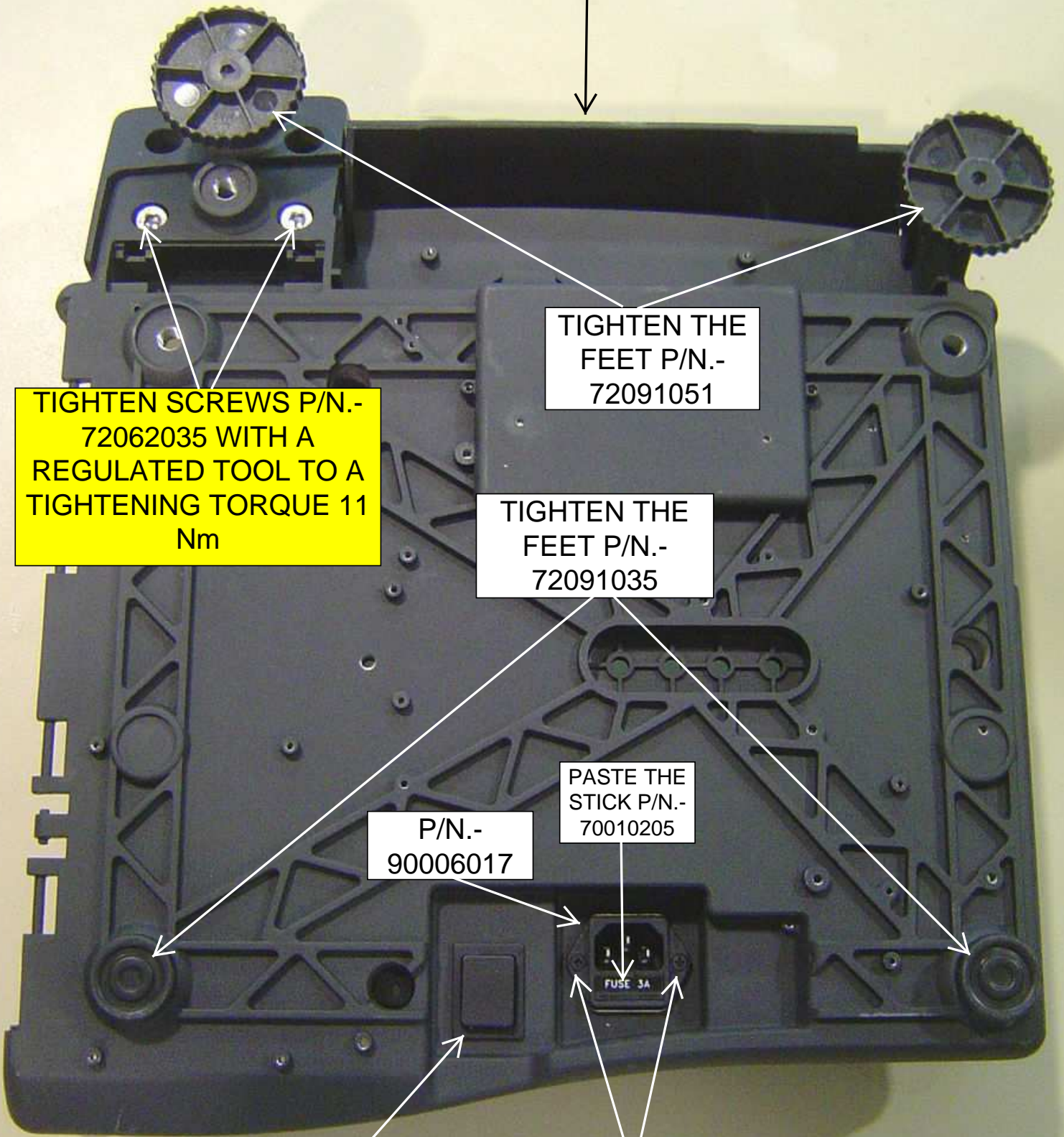

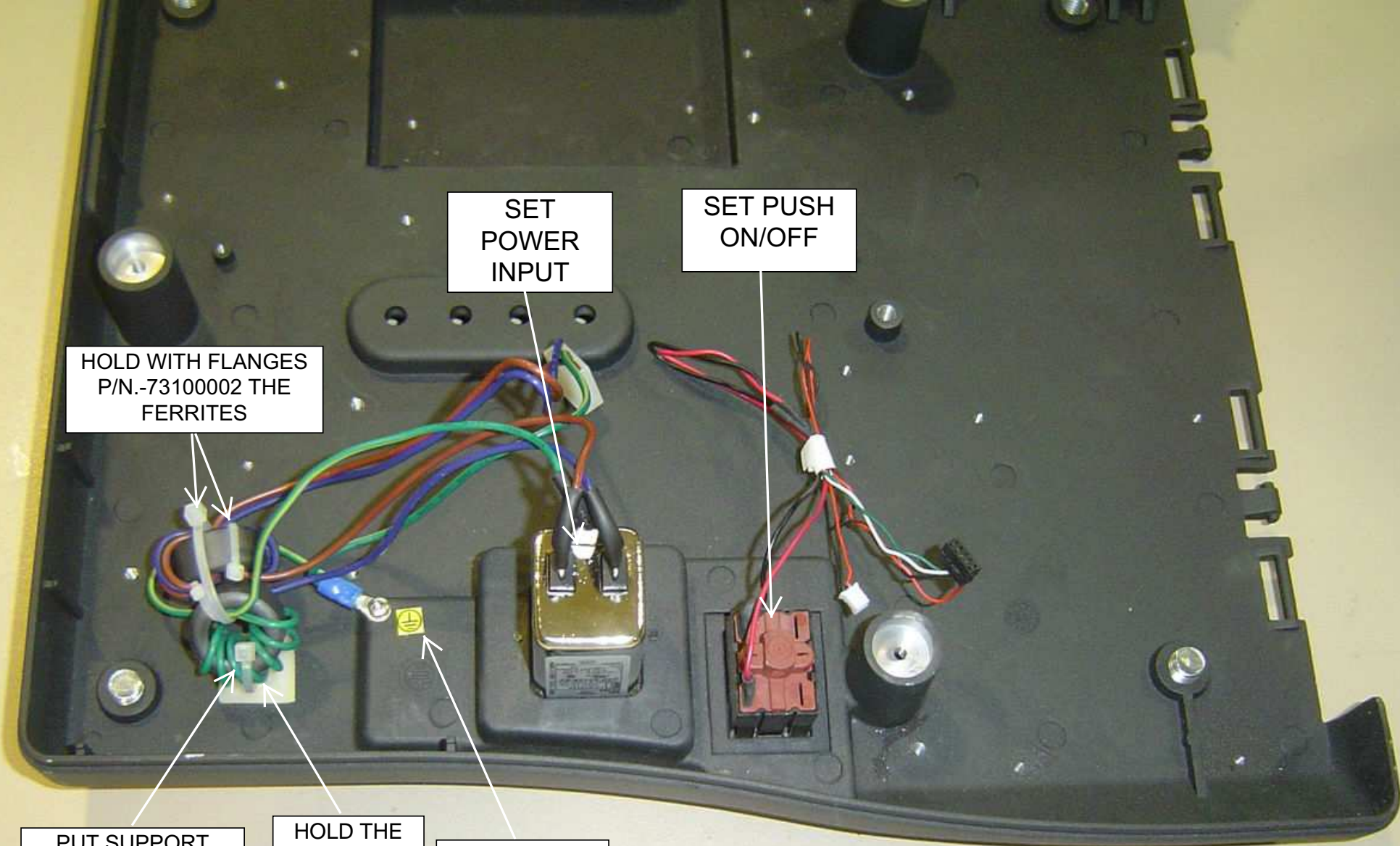

SET
POWER
INPUT

SET PUSH
ON/OFF

HOLD WITH FLANGES
P/N.-7310002 THE
FERRITES

PUT SUPPORT
FLANGE P/N.-
73120028 WITH
SCREW P/N.-
72054017

HOLD THE
GROUND
TERMINAL
WITH
SCREW P/N.-
72031015

PASTE THE
STICK P/N.-
70000546

2.- ASSEMBLY POWER SUPPLIES AND SWITCH BOARD (COMPONENTS)

P/N.-
72031015 (2)



P/N.-
73050004
(2)



P/N.-
72031016
(2)



P/N.- 72091008
(NYLON SCREW)



P/N.-
72031026



P/N.-
71100003
(4)

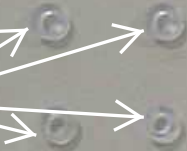

P/N.-
73100002
(2)

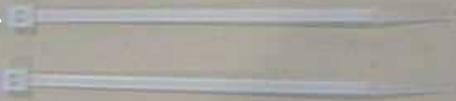

P/N.-
71210408
(2)



P/N.-
19052165



P/N.-
19052167



P/N.-
90114096



P/N.-
19052155



CONNECT CABLE P/N.-
90114096

CONNECT CABLE
P/N.- 90113962

P/N.- 72031015

P/N.-
71210408

P/N.-
73050004

P/N.-
71210408

P/N.-
73050004

HOLD WITH
FLANGE P/N.-
73100002

PASTE THE
STICK P/N.-
70000456

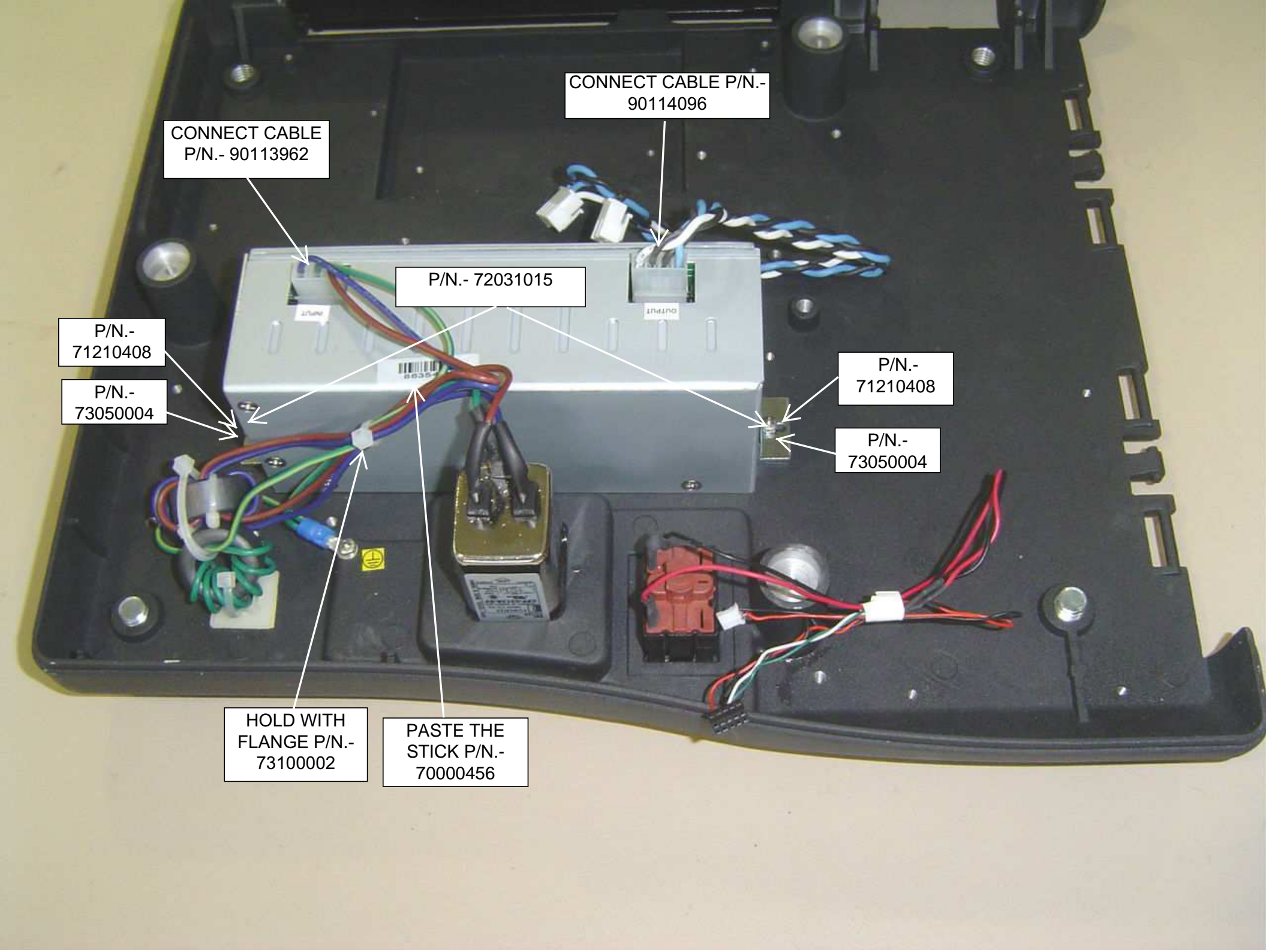

DETAIL
ASSEMBLY
POWER SUPPLY

P/N.- 71210408

P/N.- 72031015

P/N.- 73050004

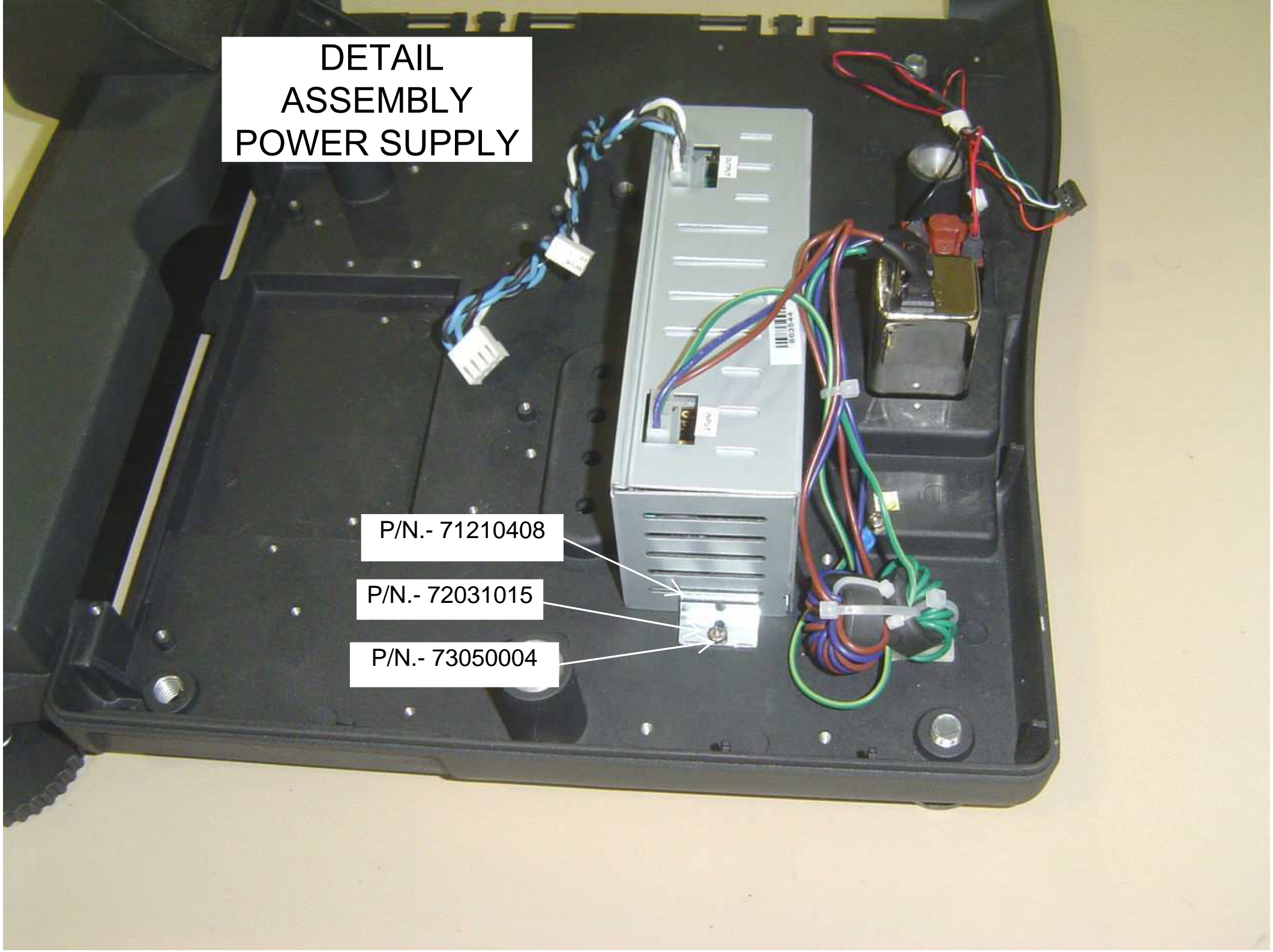

DETAIL
ASSEMBLY
POWER SUPPLY

P/N.- 71210408

P/N.- 72031015

P/N.- 73050004

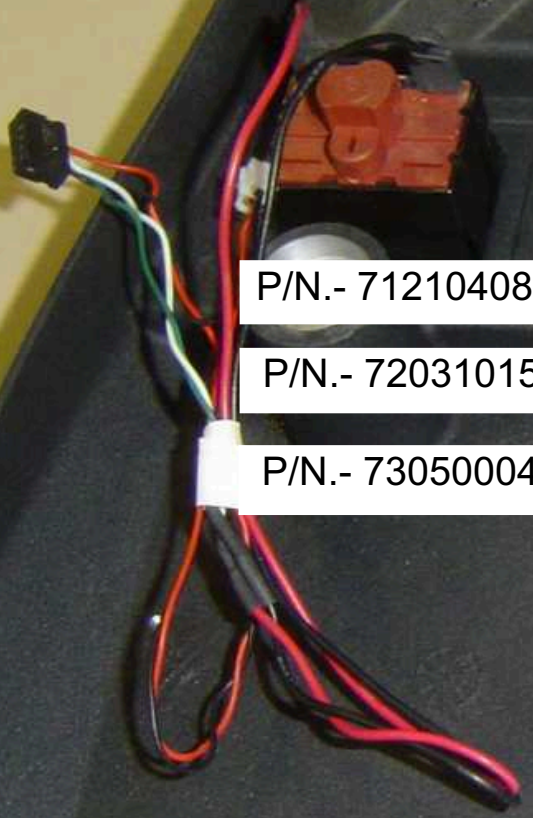

PUT THE POWER SUPPLY P/N.-
19052165 AND HOLD WITH 2
SPACERS P/N.- 71100003, SCREW
P/N.- 72031016 AND SCREW P/N.-
72091008 (SEE NEXT PICTURE)

PUT THE SWITCH BOARD
P/N.- 19052167 AND HOLD
WITH 2 SPACERS P/N.-
71100003, SCREW P/N.-
72031016 AND 72031026
(SEE NEXT PICTURE)

CONNECT CABLE IN
POWER SUPPLY
AND SWITCH
BOARD

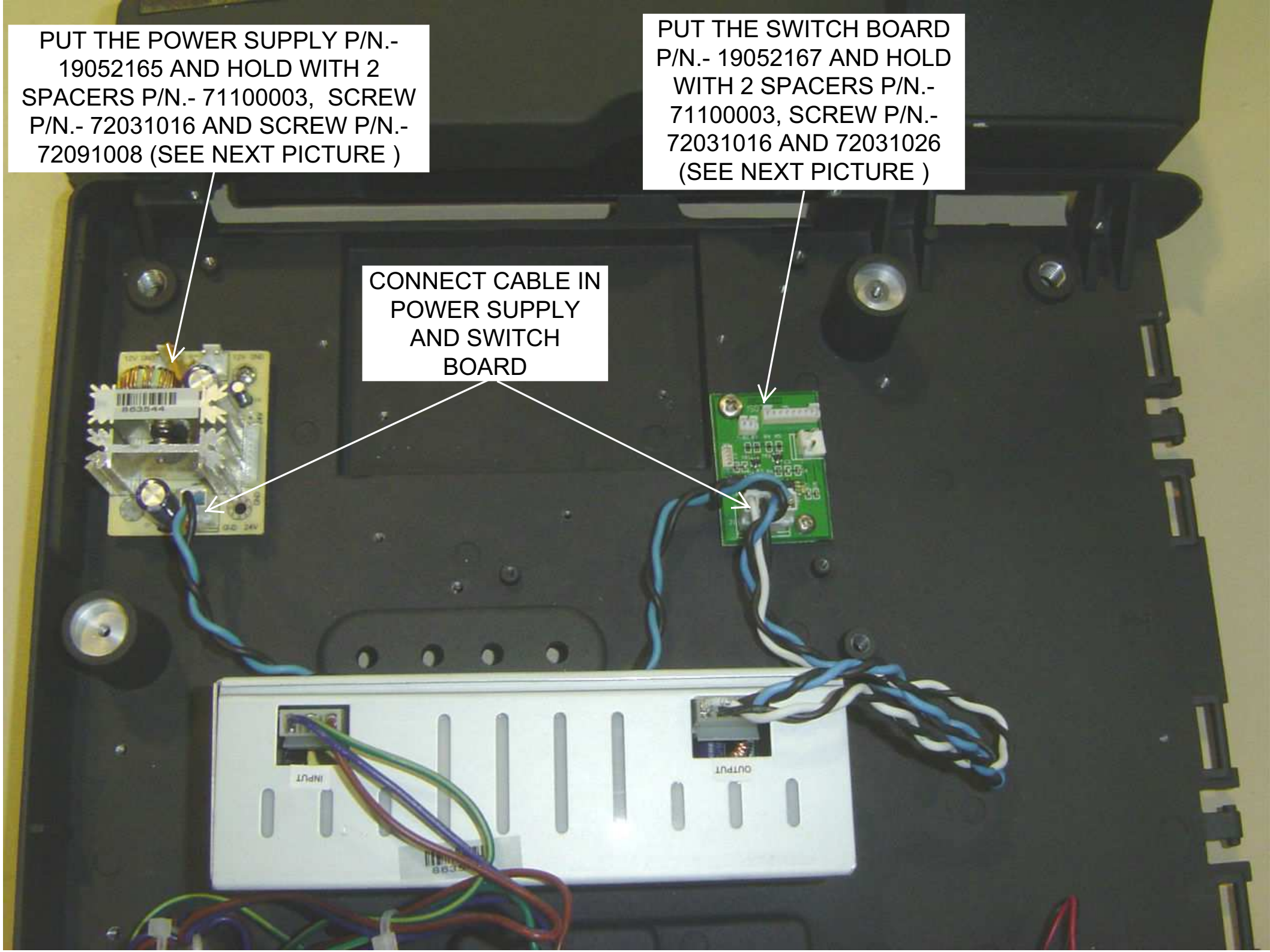

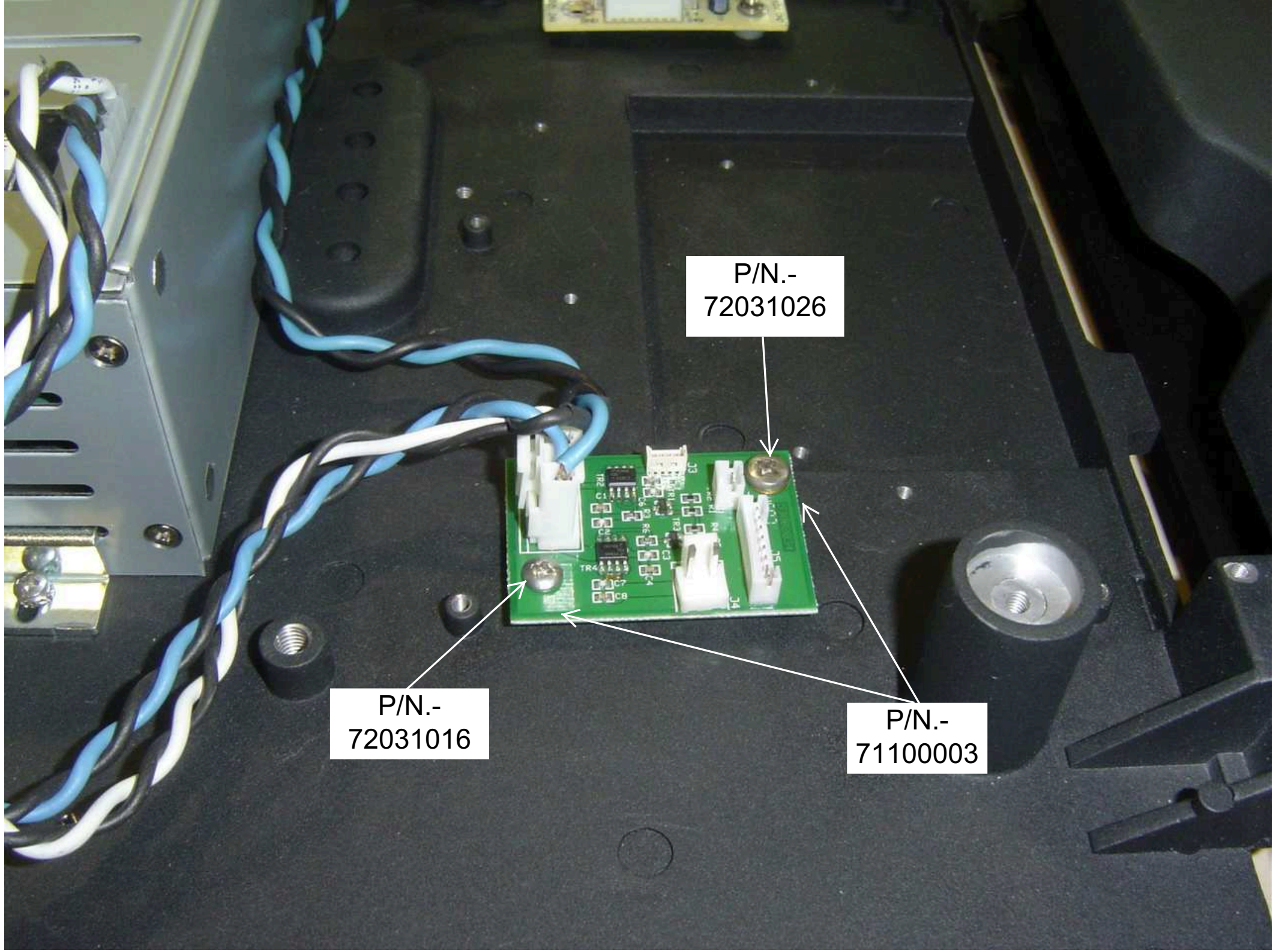

P/N.-
72031026

P/N.-
72031016

P/N.-
71100003

P/N.-
71100003

P/N.-
72031016

PASTE THE
STICK P/N.-
70000456

PUT HERE P/N.-
72091008 (NYLON
SCREW)

P/N.-
71100003

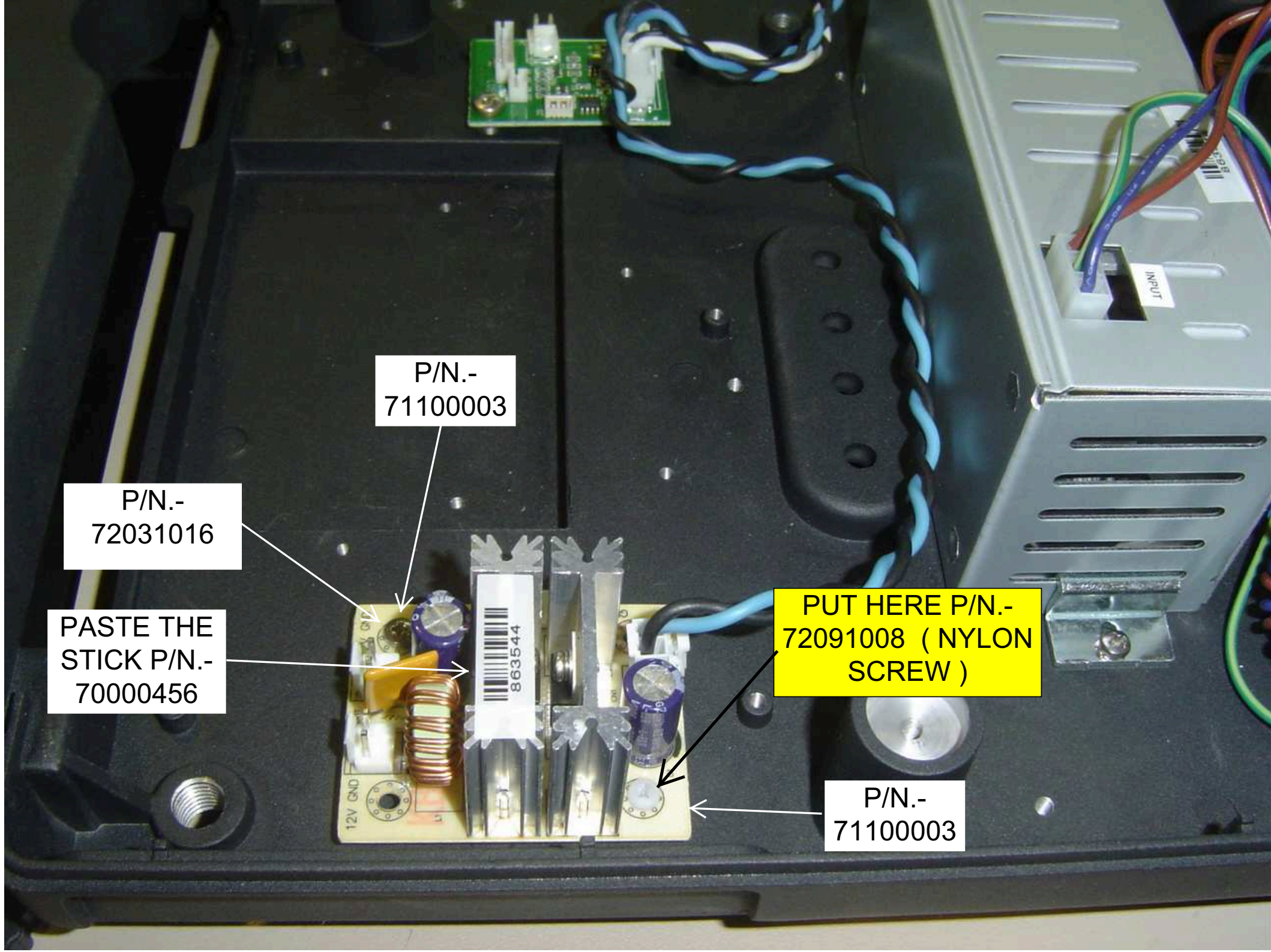

3.- ASSEMBLY SET LOAD CELL P/N.- 97003239 (COMPONENTS)

P/N.- 97003224
(FOR 15 Kg)

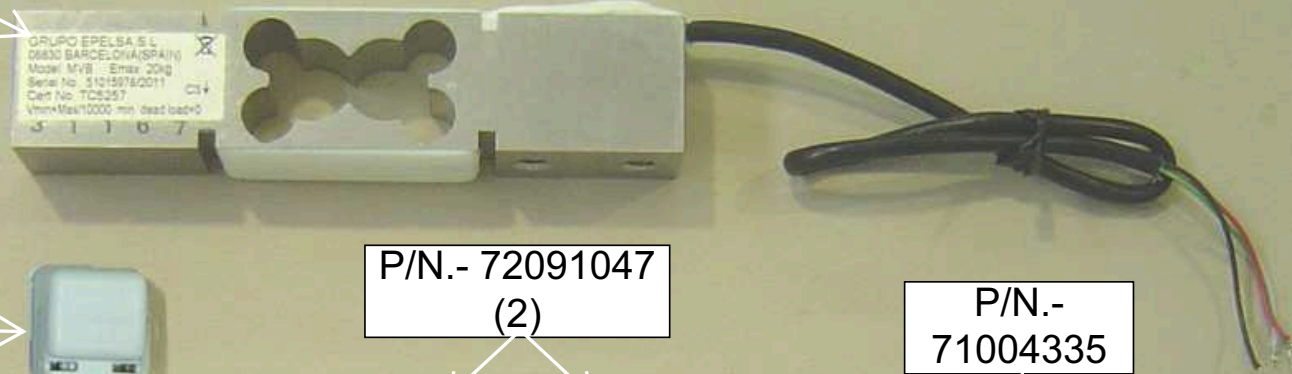

P/N.-
93002035



P/N.- 72091047
(2)



P/N.-
71004335



P/N.-
71101024



P/N.-
71101022



P/N.- 73003001
(2)



3.- ASSEMBLY SET LOAD CELL P/N.- 97003239 (COMPONENTS)

P/N.-
19016800



P/N.-
71210520



P/N.-
112583

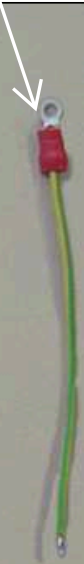

P/N.-
19016900

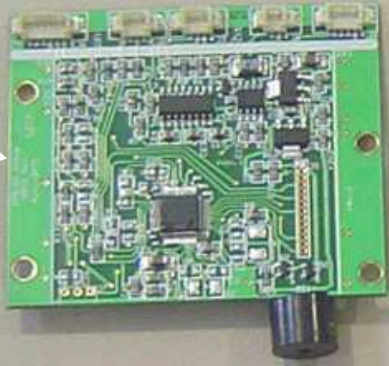

P/N.-
71002295



RIVET P/N.- 72300013
(3 x 16) (4)

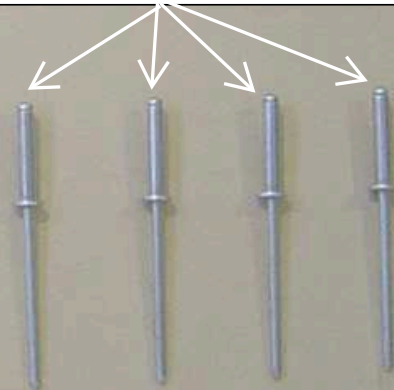

P/N.-
71100003 (4)

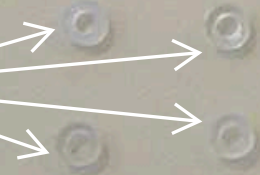

P/N.-
79900061



3.- ASSEMBLY SET LOAD CELL P/N.- 97003239 (COMPONENTS)

P/N.-
90113984



P/N.-
72012025



P/N.-
71210414



P/N.-
72031015



P/N.-
72102009



P/N.-
73050004



P/N.-
73050007





CUT THE WIRES
OF THE LOAD
CELL TO A
LENGTH OF 2 cm



SOLDER DE CABLE P/N.-
112583 TO LOAD CELL
GROUND CABLE PUTTING
SHRINK P/N.-
79900061

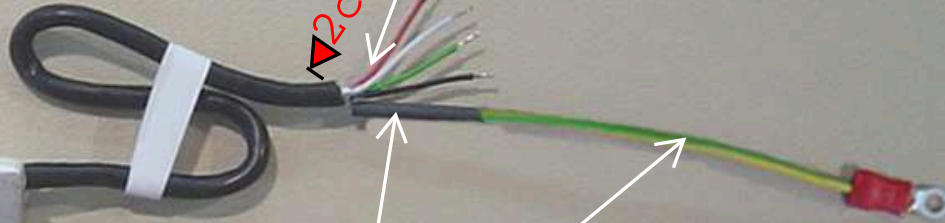

SOLDER THE LOAD
CELL CABLES IN BOARD
P/N.- 19016800

RED

BLACK

GREEN

WHITE

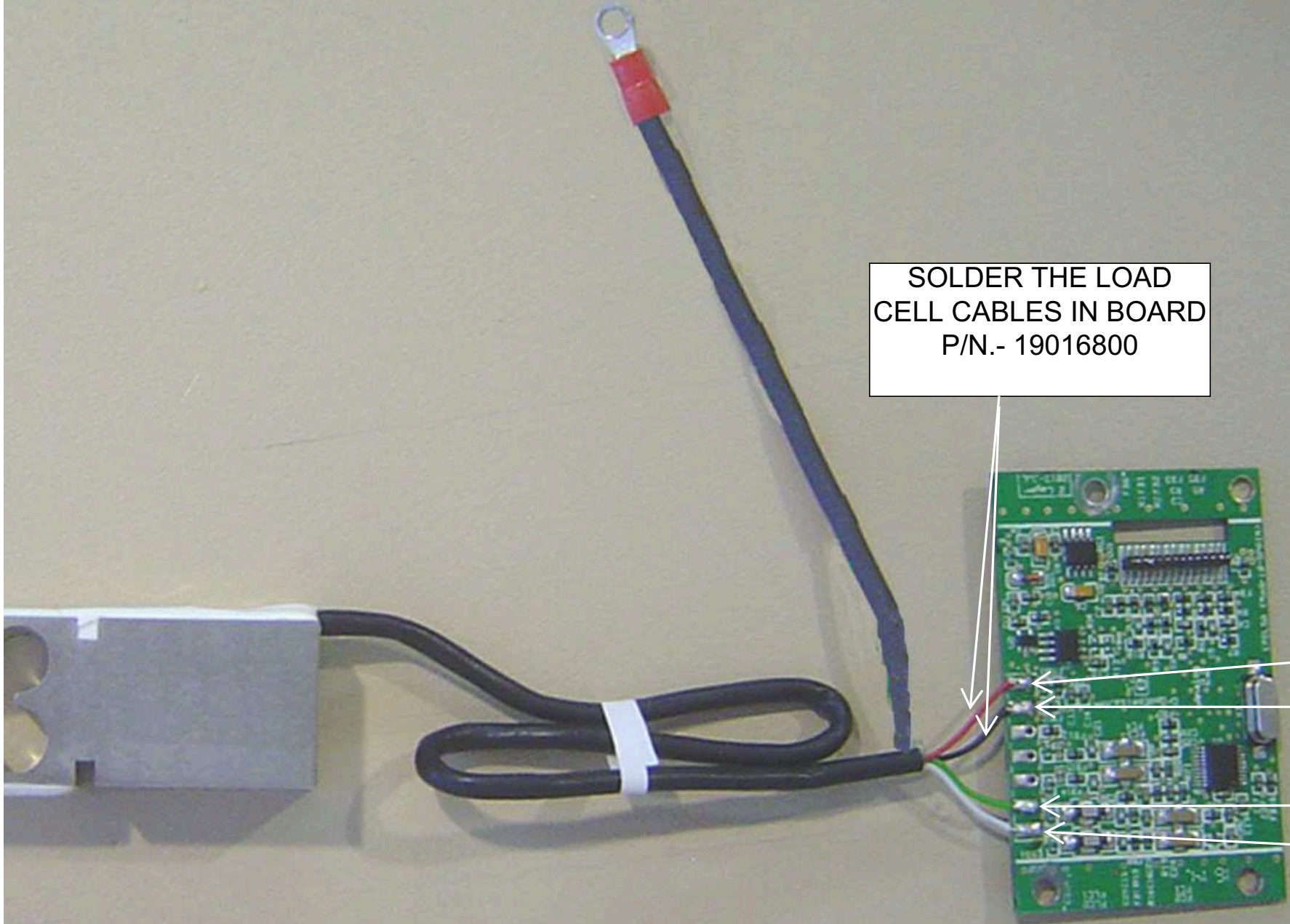

PUT SPACER P/N.- 71100003 AND GUIDE-SCREW TO ASSEMBLY ANALOG BOARD AND BPTC BOARD (P/N.- 19016900). AFTER ASSEMBLY SOLDER PINS IN J5

GUIDE SCREWS

SPACERS

SOLDER 14 PINS AT J5

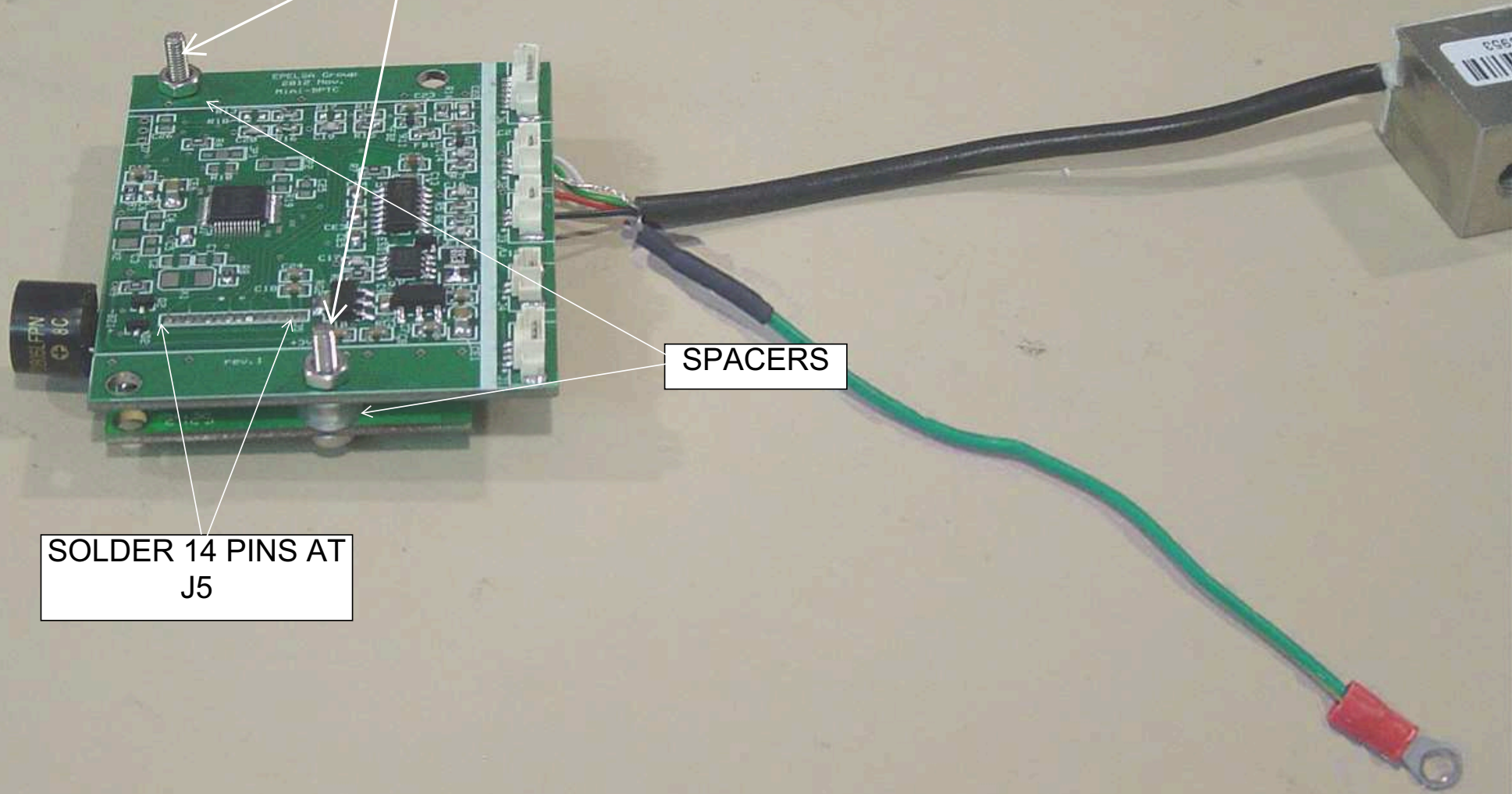

ASSEMBLY SET DIGITAL LOAD CELL

HOLD ALL
TOGETHER WITH 4
RIVETS

RIVET P/N.-
72300013

P/N.- 71002295

P/N.- 19016900

P/N.- 71100003

P/N.- 19016800

P/N.- 71004335

P/N.- 71210520

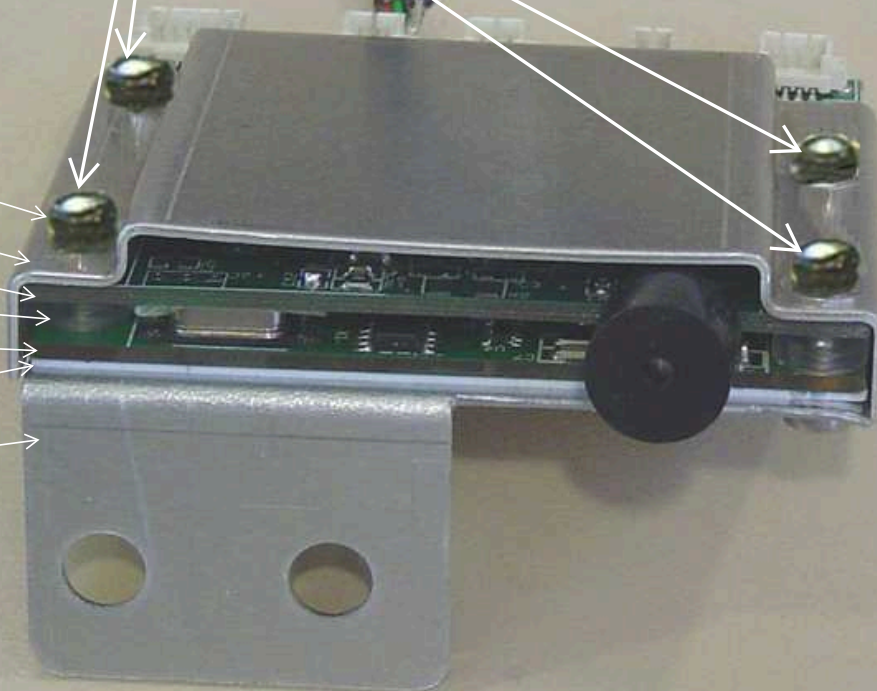

JOIN THE SET
WITH 4 RIVETS

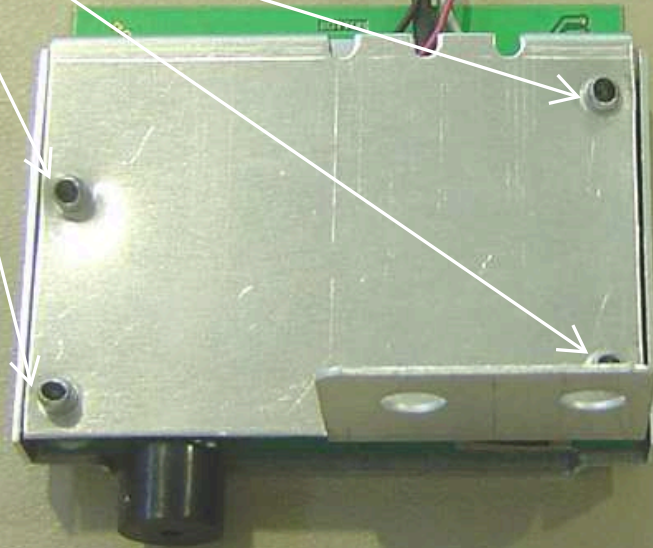

HOLD CABLES WITH
FLANGE P/N.-
73100002 (THIS IS
IMPORTANT TO AVOID
CABLES TOUCH LOAD
CELL)

RUNNING THE WIRES
UNDER THE GUIDE
LIKE SHOW IN
PICTURE

CONNECT THE
CABLE P/N.-
90114095

ASSEMBLY CABLE
GUIDE P/N.- 71210414
WITH SCREW P/N.-
19031015 AND
WASHER P/N.-
73050004

THREAD THE SCREW P/N.-
72012025 WITH WASHER P/
N.- 73050007 AND NUT P/N.-
72102009

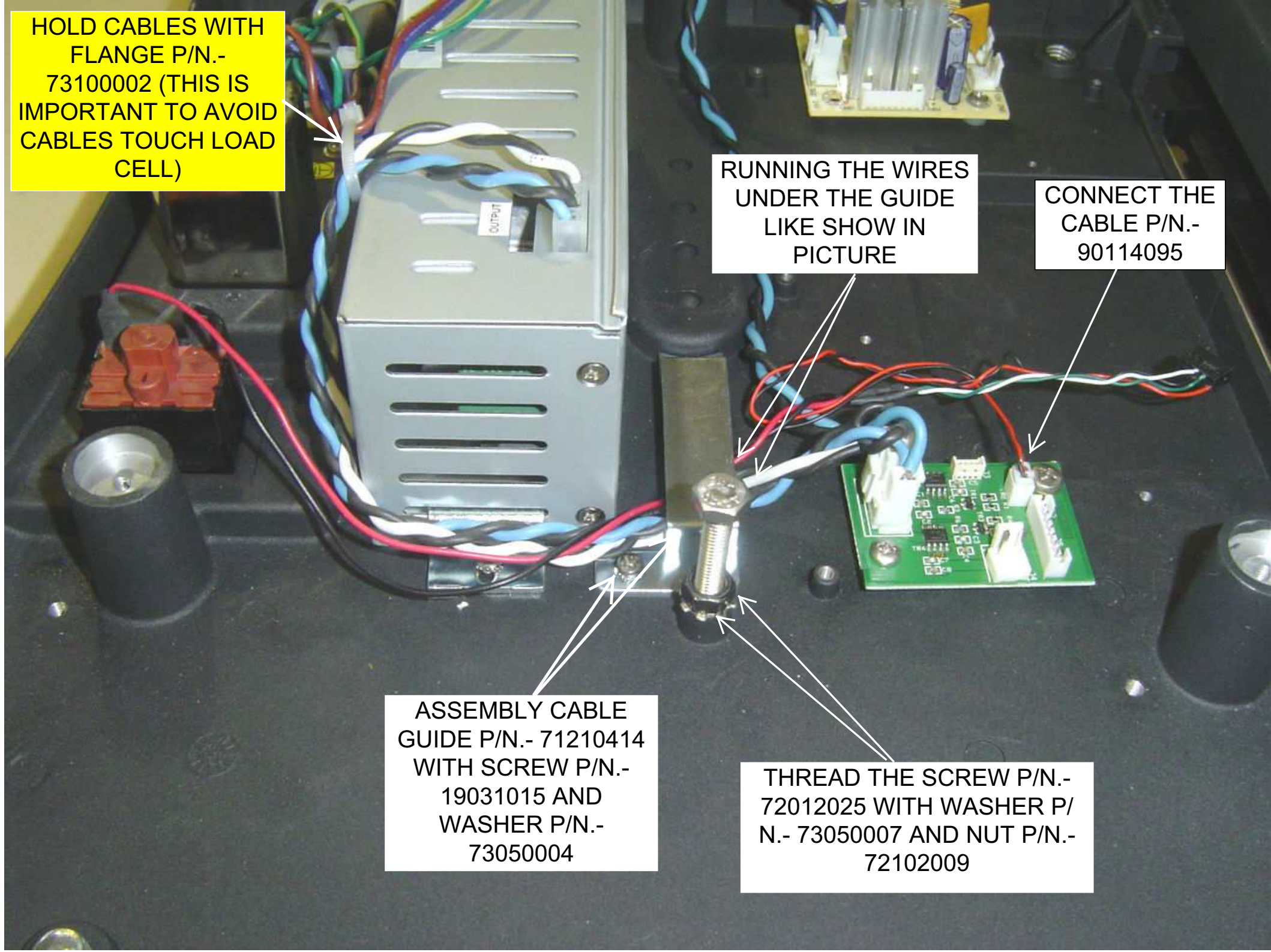

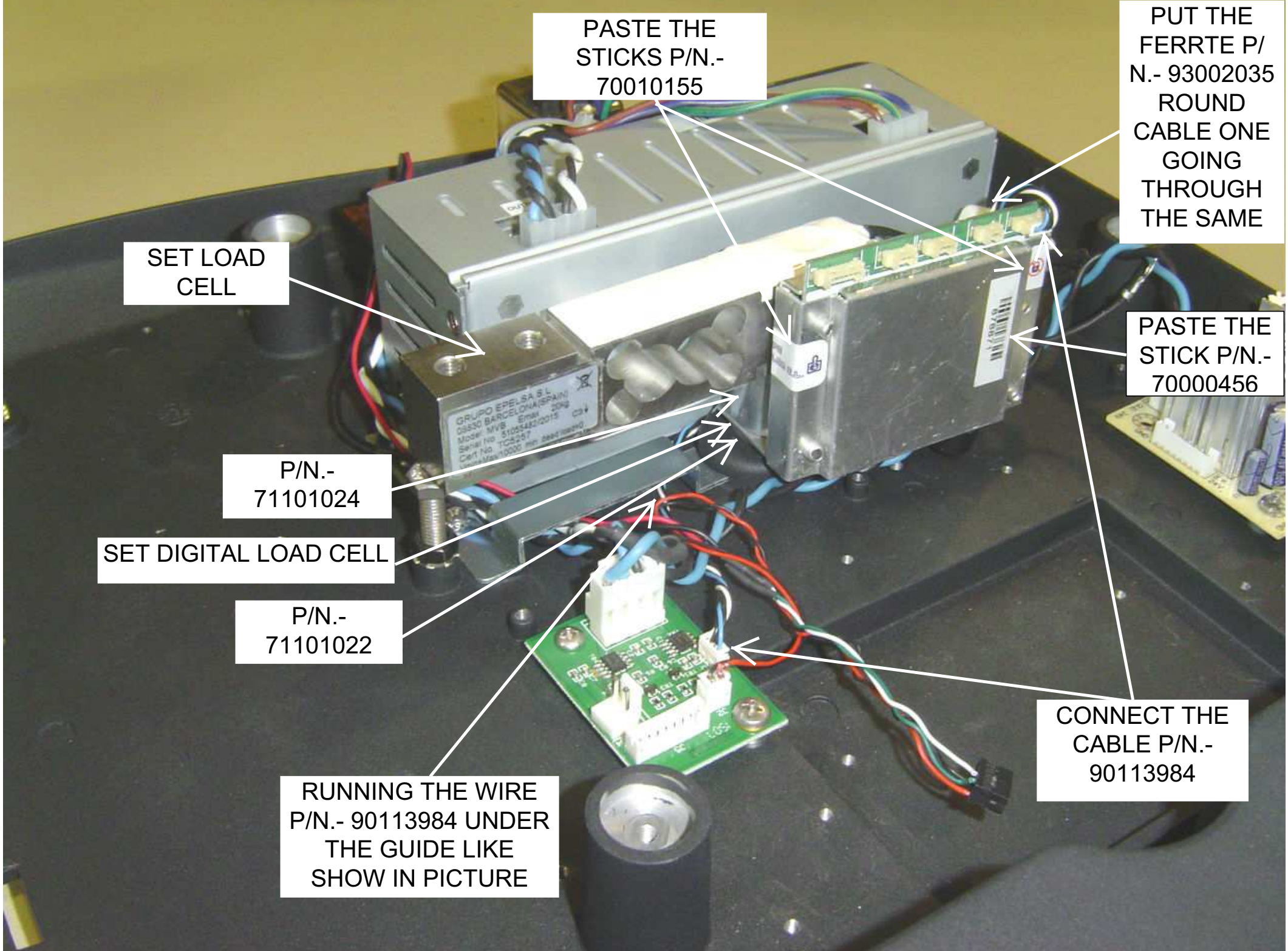

PASTE THE STICKS P/N.- 70010155

PUT THE FERRITE P/ N.- 93002035 ROUND CABLE ONE GOING THROUGH THE SAME

SET LOAD CELL

PASTE THE STICK P/N.- 70000456

P/N.- 71101024

SET DIGITAL LOAD CELL

P/N.- 71101022

CONNECT THE CABLE P/N.- 90113984

RUNNING THE WIRE P/N.- 90113984 UNDER THE GUIDE LIKE SHOW IN PICTURE

SCREWS P/N.-
72091047
TIGHTEN WITH A
REGULATED
TOOL TO A
TIGHTENING
TORQUE 11 Nm

P/N.- 73003001

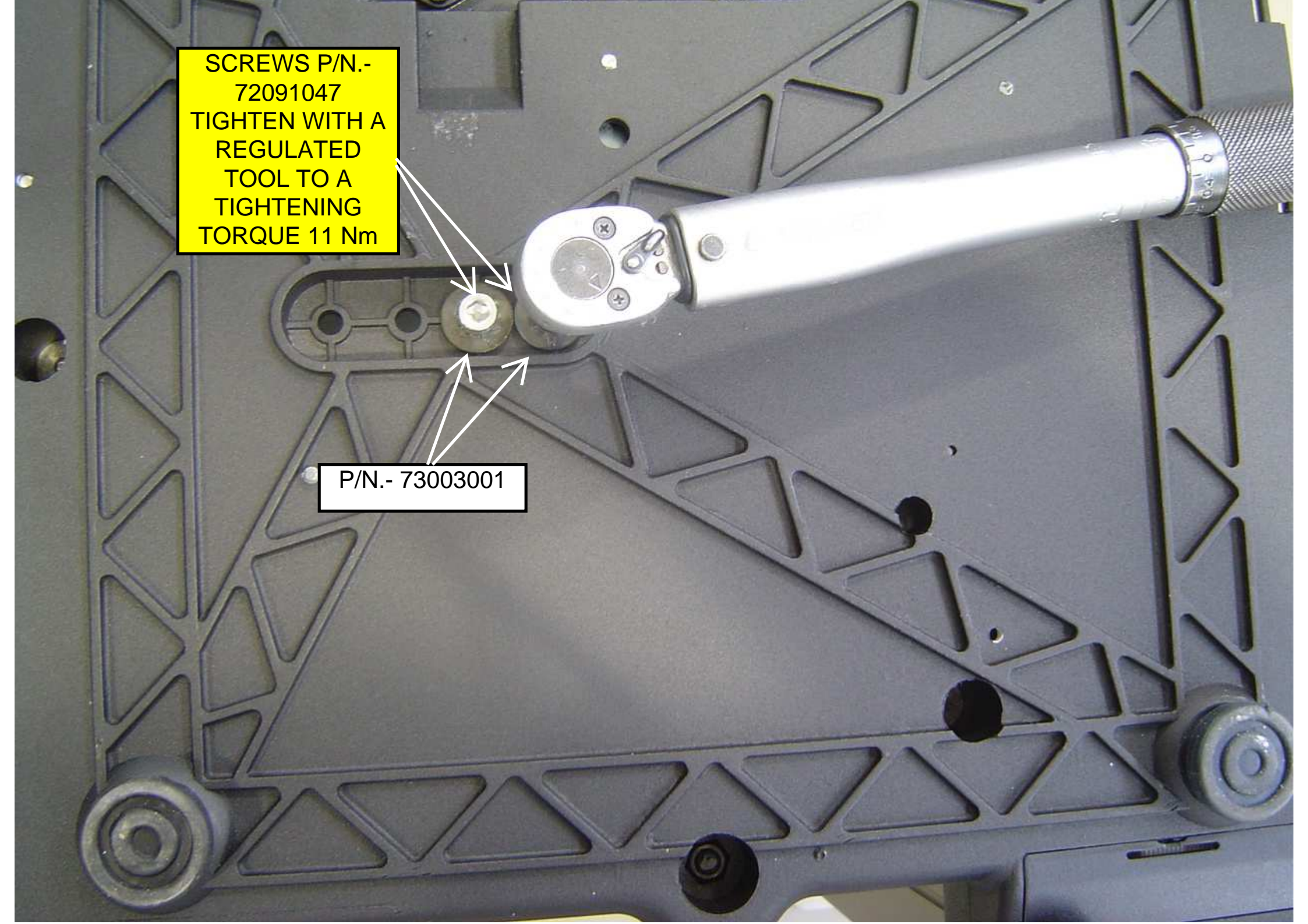

TERMINAL
GROUND
TERMINAL OF
LOAD CELL

OTHER VIEW OF ASSEMBLY THE
FERRITE P/N.- 93002035 AND
HOLD WITH A FLANGE P/N.-
73100002



PASTE THE
STICK P/N.-
70000456

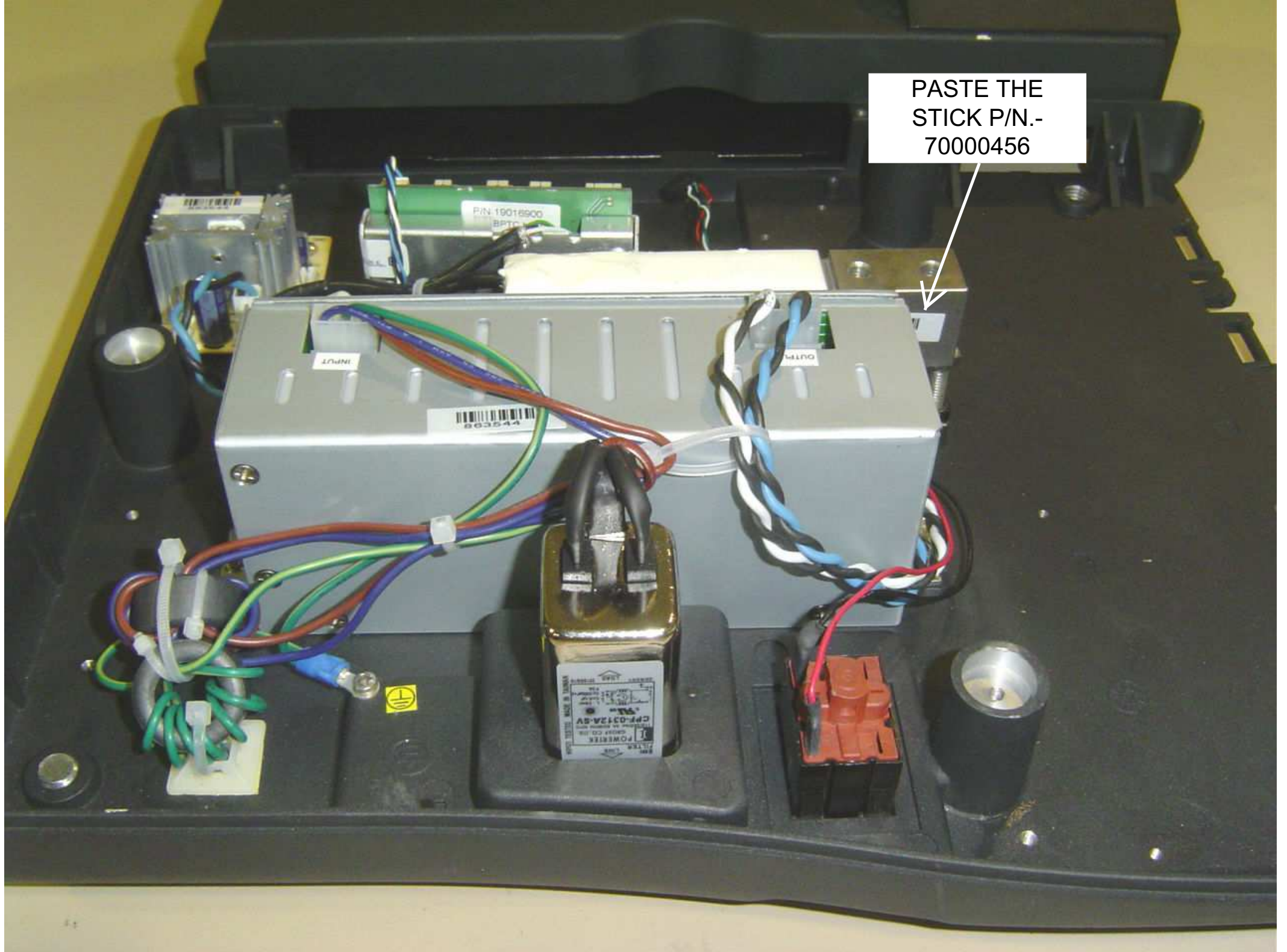

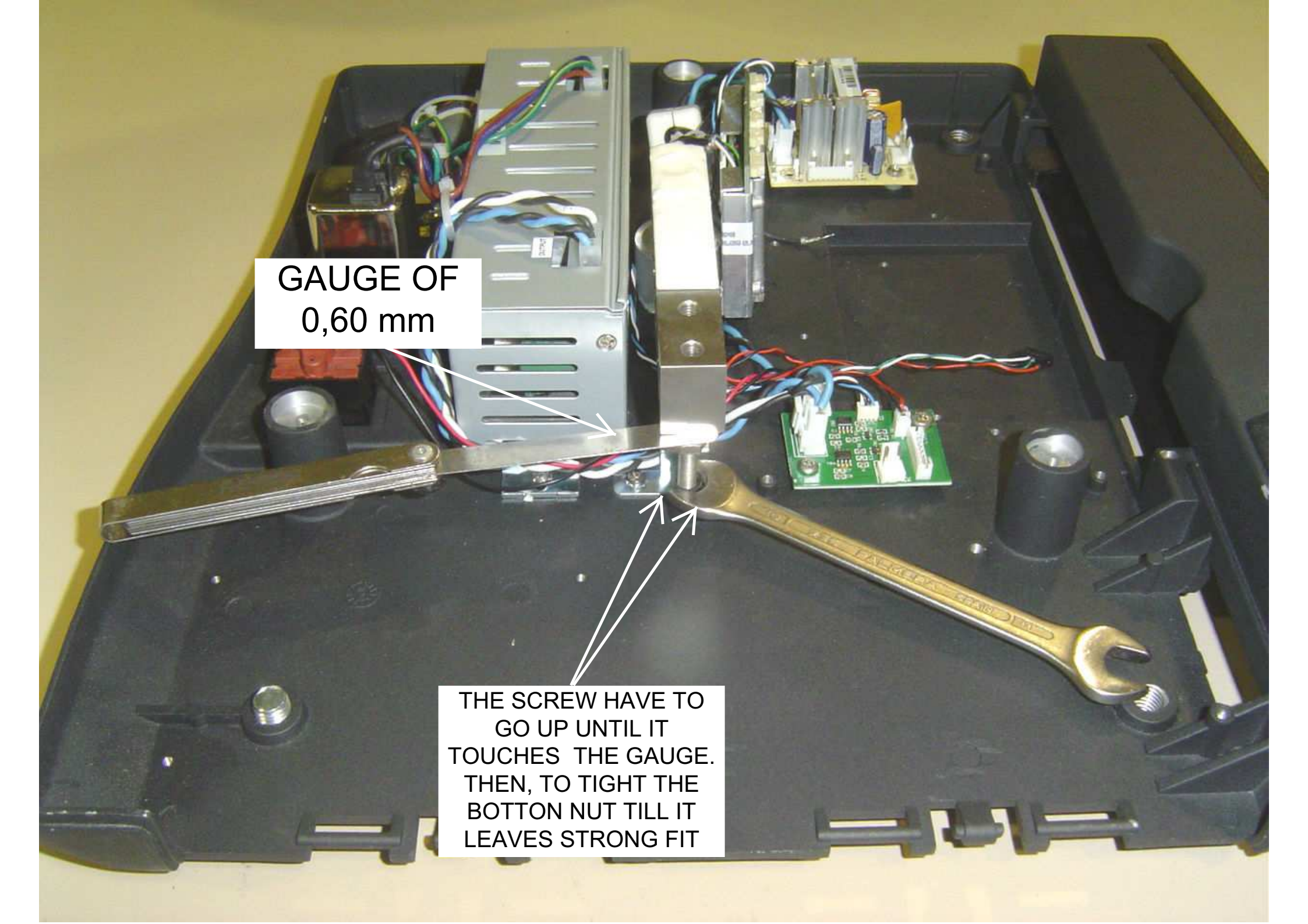

GAUGE OF
0,60 mm

THE SCREW HAVE TO
GO UP UNTIL IT
TOUCHES THE GAUGE.
THEN, TO TIGHT THE
BOTTON NUT TILL IT
LEAVES STRONG FIT

4. ASSEMBLY PICO ITX BOARD AND CONNECTIONS BADGE

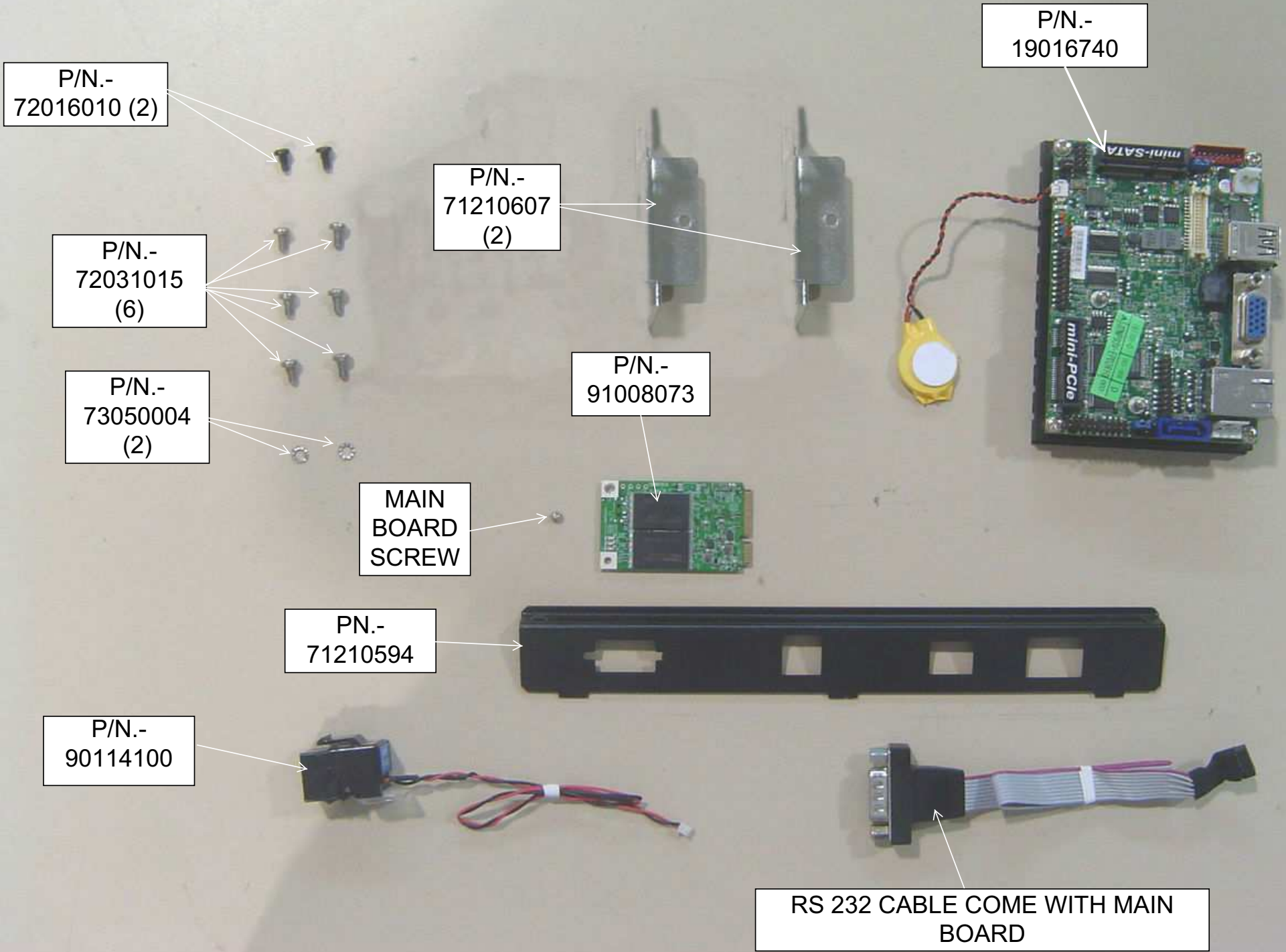

CONNECT FLASH
DISK MINI-SATA
AND HOLD WITH
THE SCREW

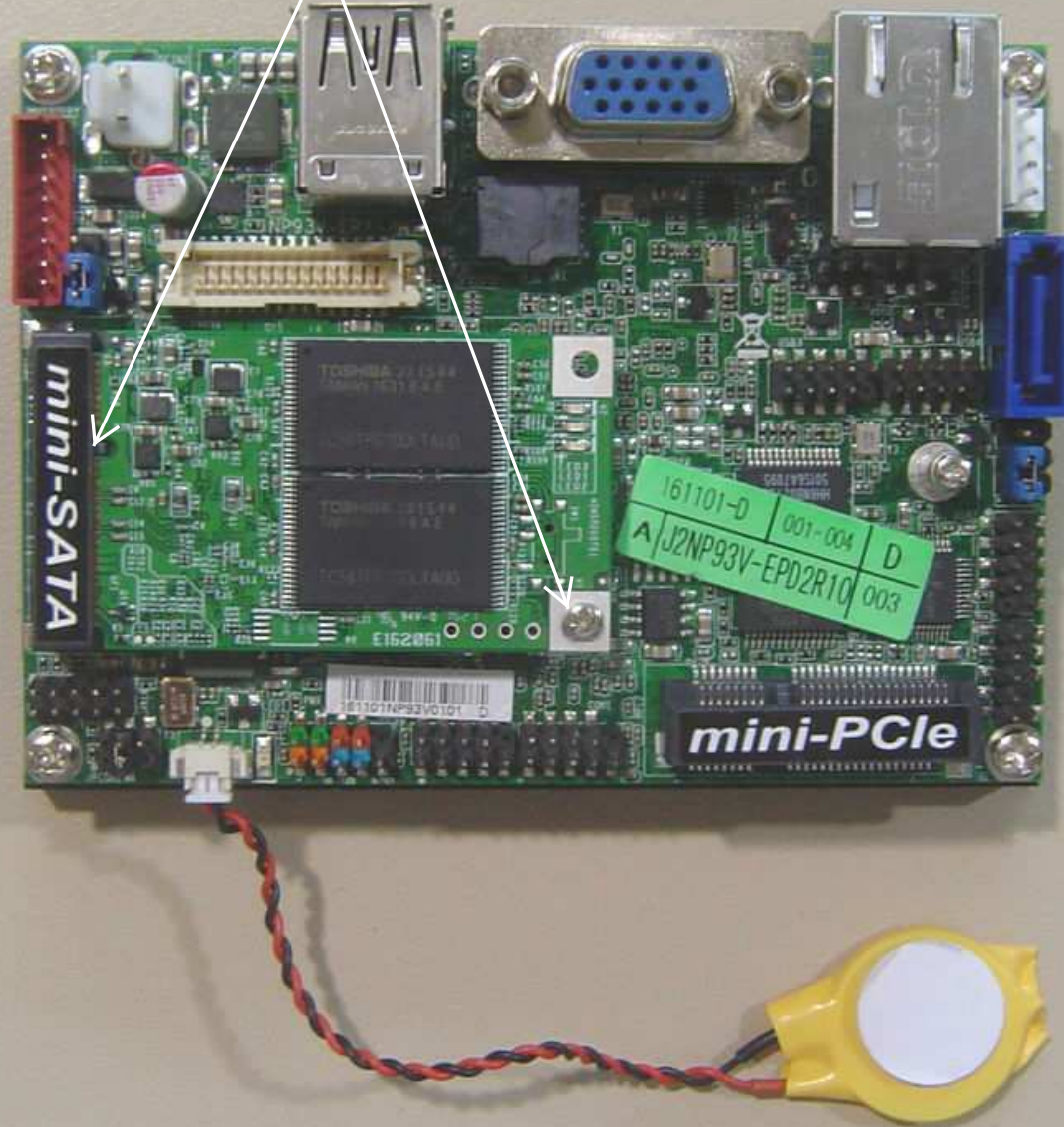

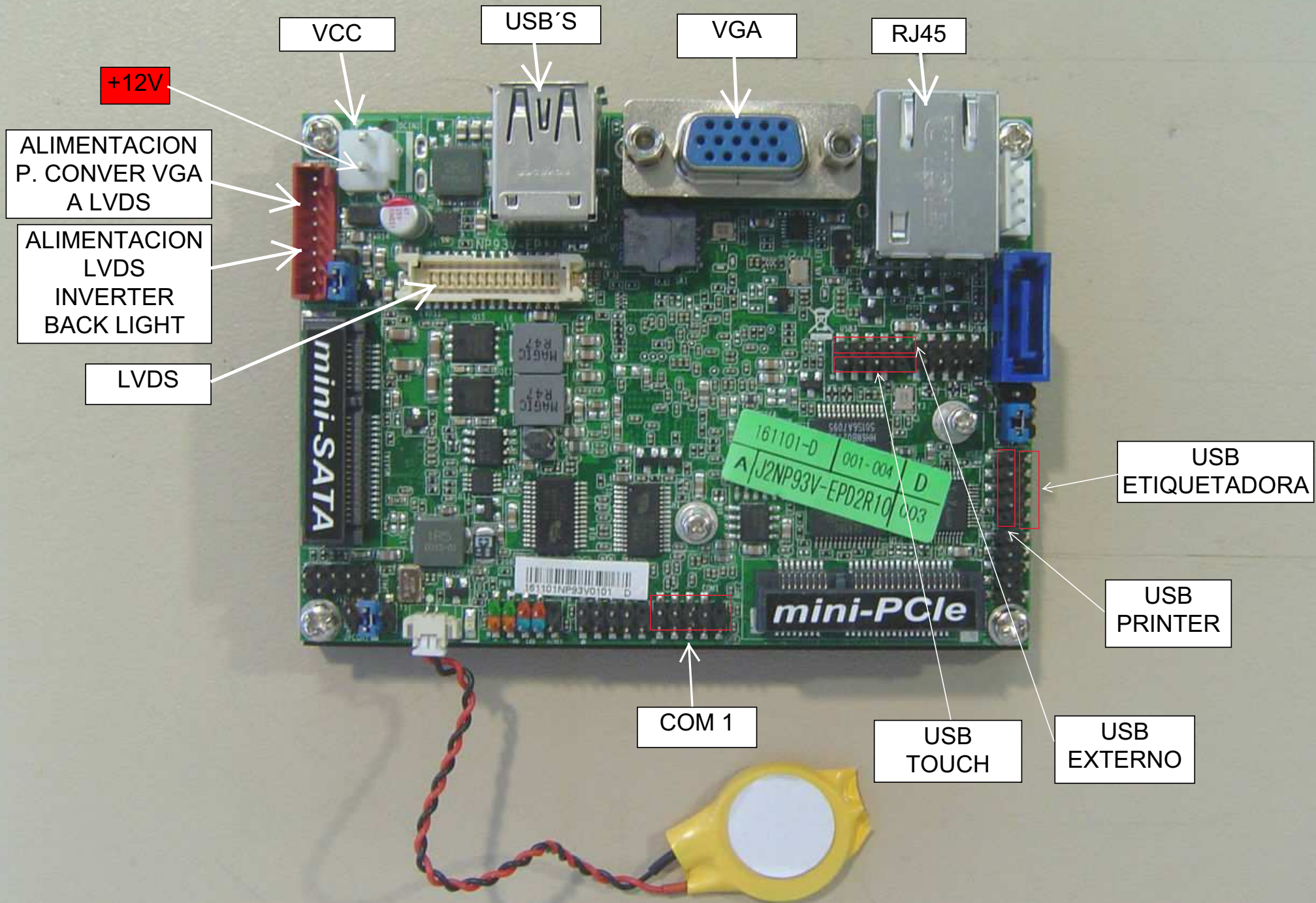

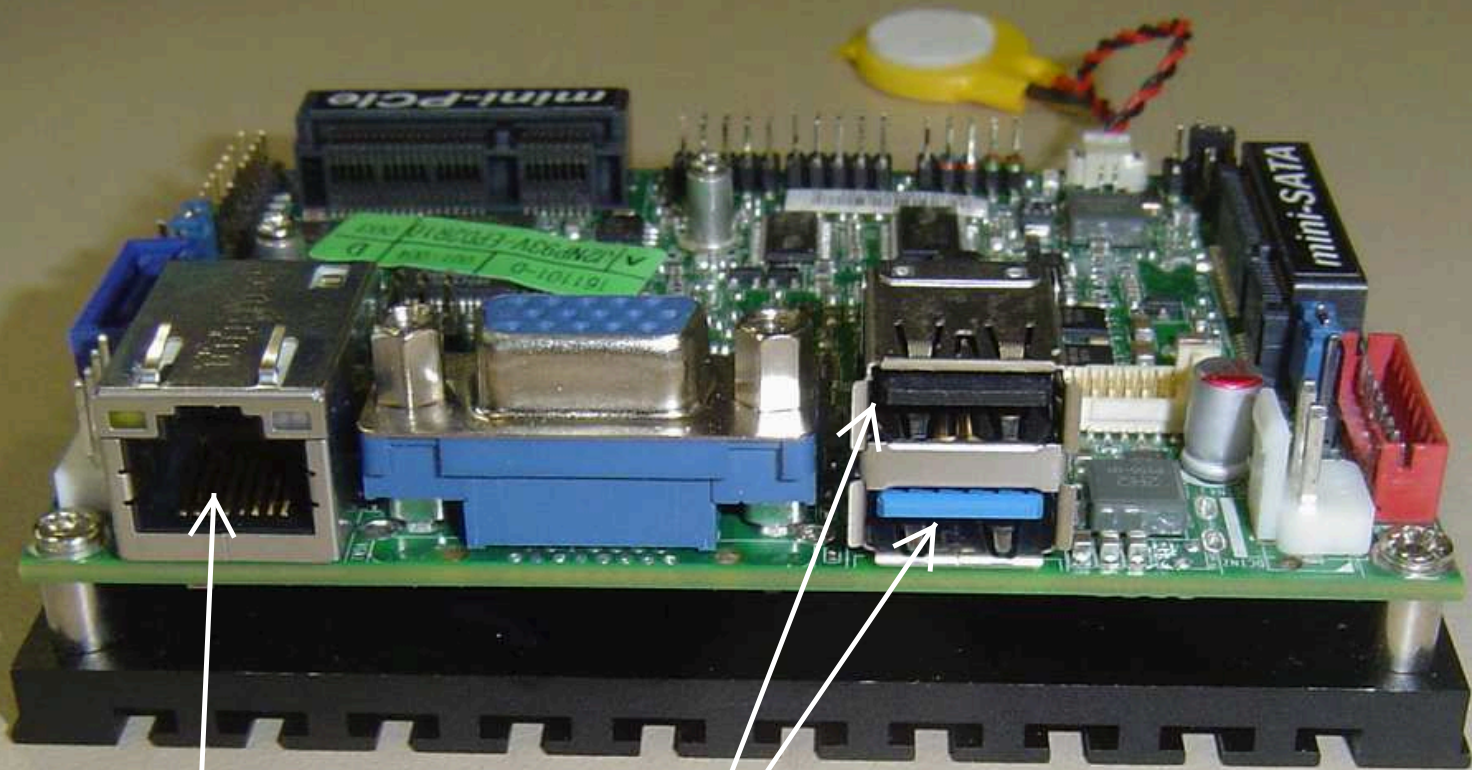

RJ45

USB'S



ASSEMBLY THE
CONNECTOR OF
CABLE P/N.-
90114100 AT THIS
POSICIÓN

ASSEMBLY THE CONNECTOR
OF RS232 CABLE AT THIS
POSITION AND HOLD WITH
THE TURRETS

BACK VIEW

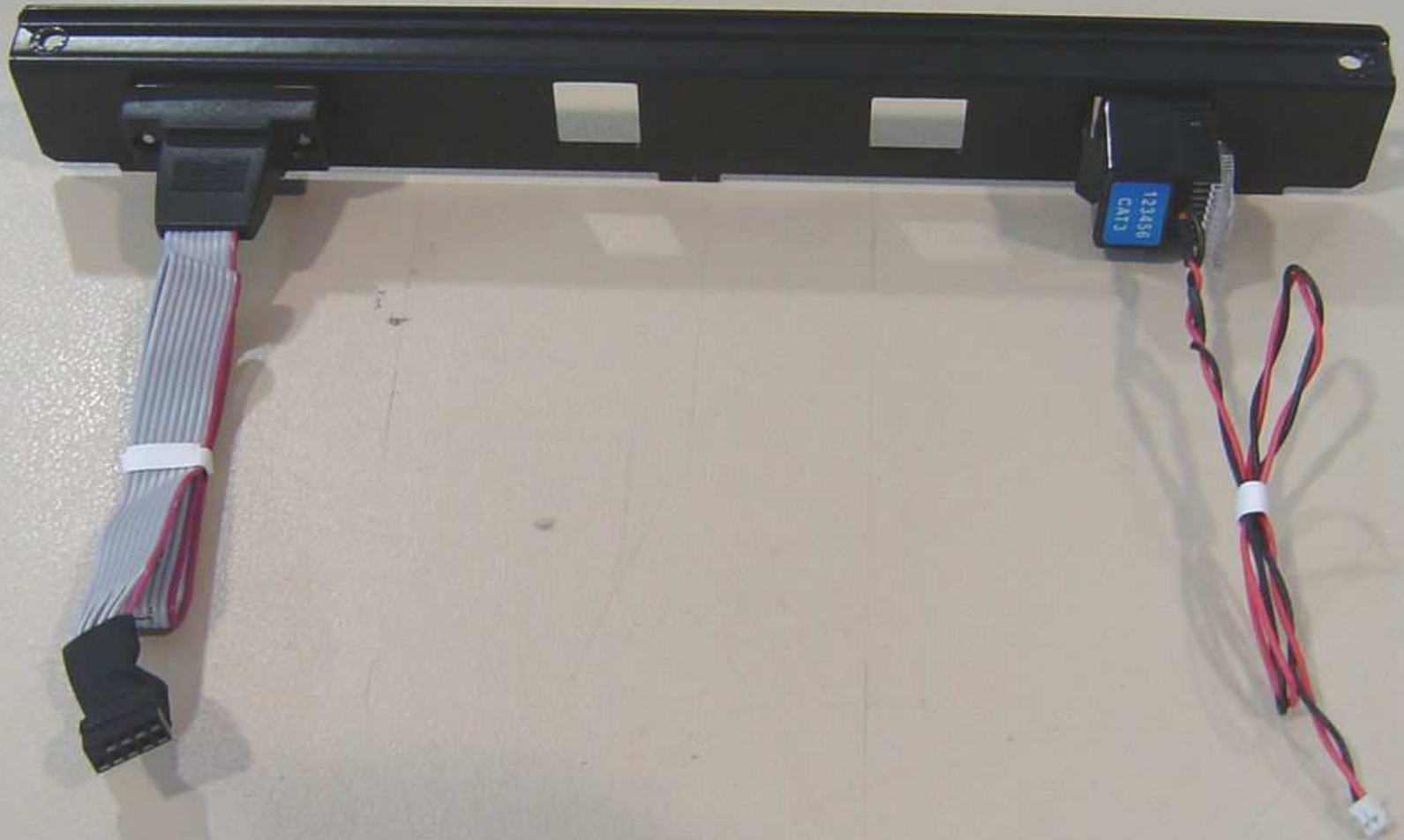

ASSEMBLY THE
CONNECTIONS BADGE AND
HOLD WITH 2 SCREWS P/N.-
72016010



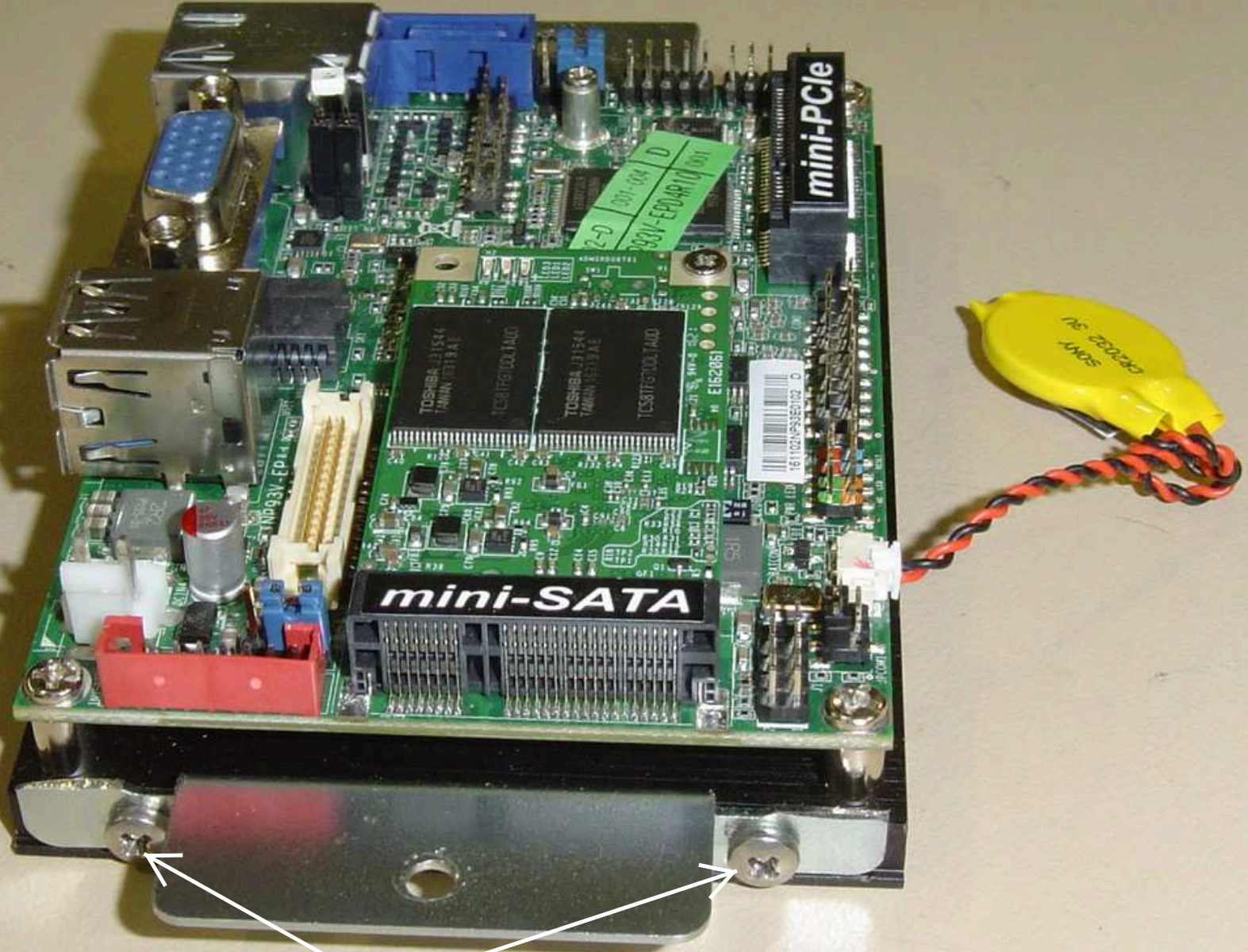

HOLD THE SUPPORT PN.- 71210607 TO THE MAIN BOARD WITH SCREWS P/N.- 72031015



HOLD THE SUPPORT PN.- 71210607 TO THE MAIN BOARD WITH SCREWS P/N.- 72031015

CONNECT THE
CABLE P/N.-
90114100

CONNECT THE CABLE P/N.-
90114095 (SEE NEXT
PICTURE)

CONNECT RS 232
CABLE. (SEE NEXT
PICTURE)

PASTE THE
BATTERY

HOLD WITH
FLANGE

HOLD THE SUPPORT WITH 2
SCREWS P/N.- 72031015 AND 2
WHASERS P/N.- 73050004

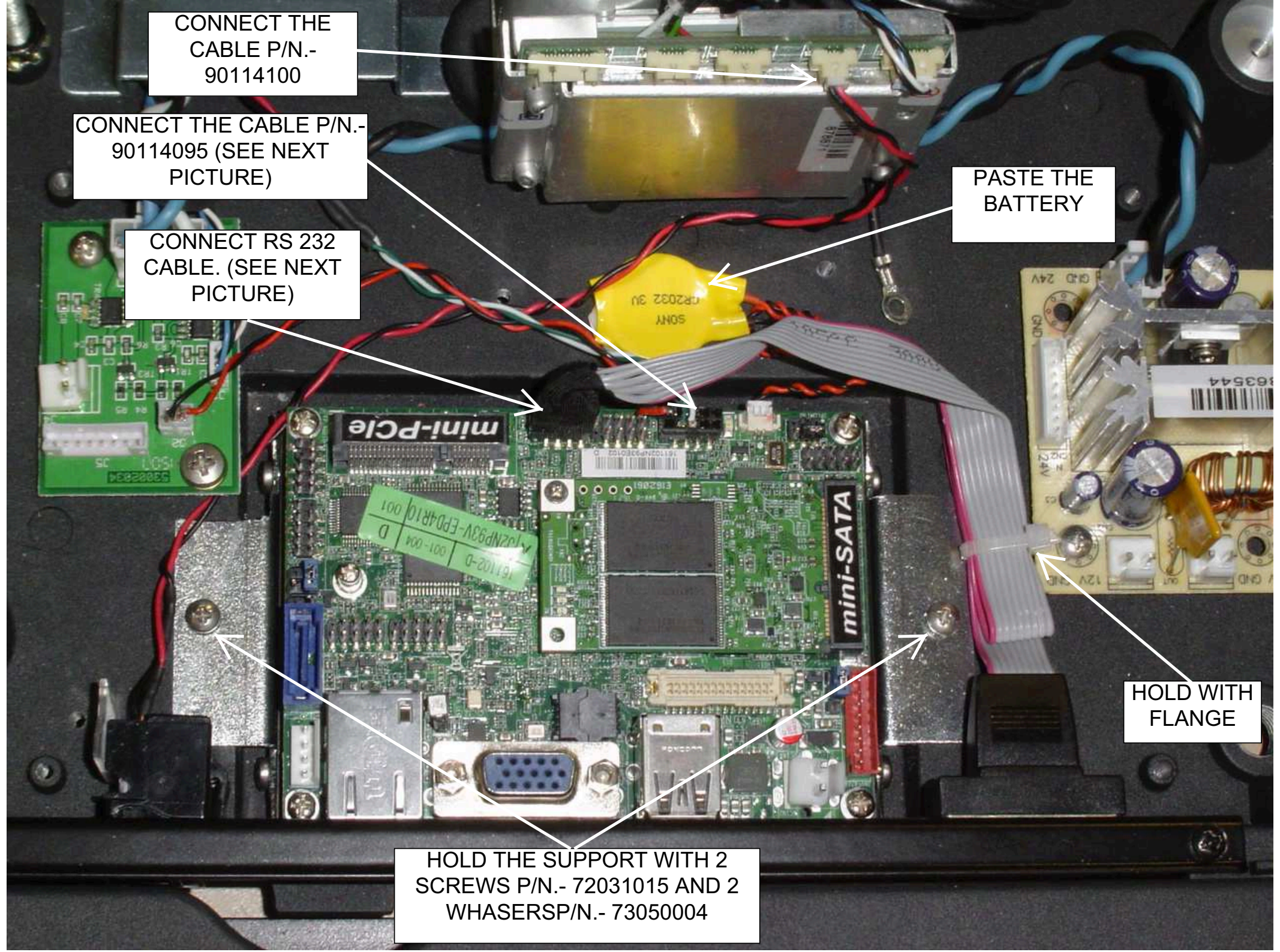

08830 BARCELONA (SPAIN)
Model: MVB Emax 20kg
Serial No. 51055482/2015
Cert No. TC5257
Vmin*Max/10000 min dead/tyd=0
C3↓

CONNECT THE
CABLE P/N.-
90114100

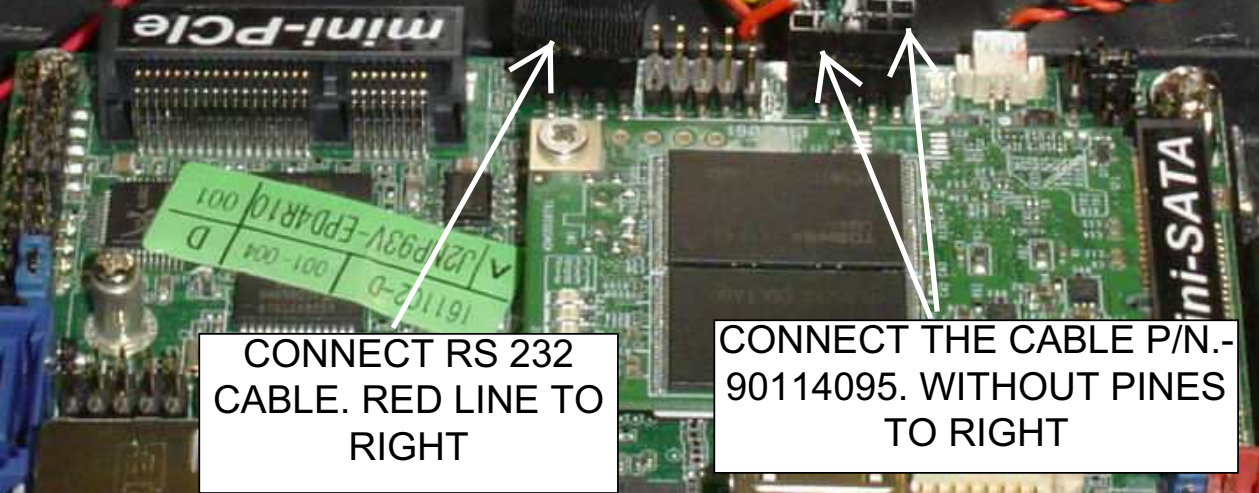

CONNECT RS 232
CABLE. RED LINE TO
RIGHT

CONNECT THE CABLE P/N.-
90114095. WITHOUT PINES
TO RIGHT



5.- CONNECT CABLES (COMPONENTS)

P/N.-
90114089



P/N.-
90114098



P/N.-
90114097

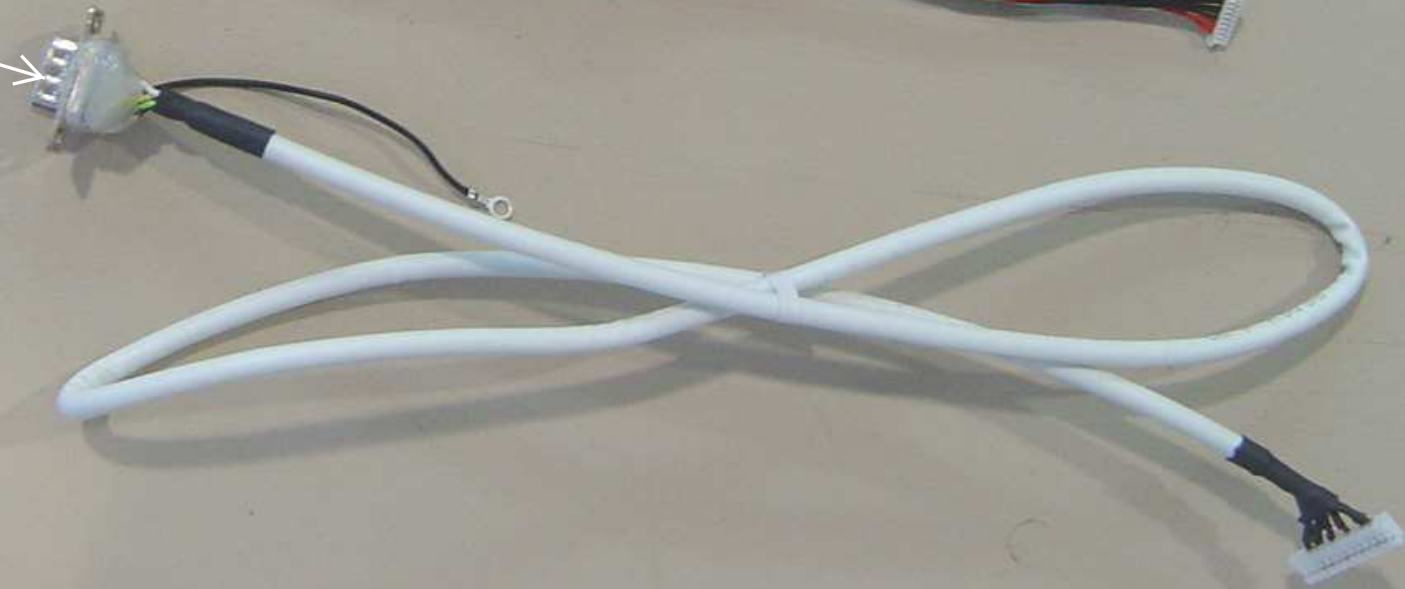

5.- CONNECT CABLES (COMPONENTS)

P/N.-
90113910



P/N.-
90114054



P/N.-
90114090

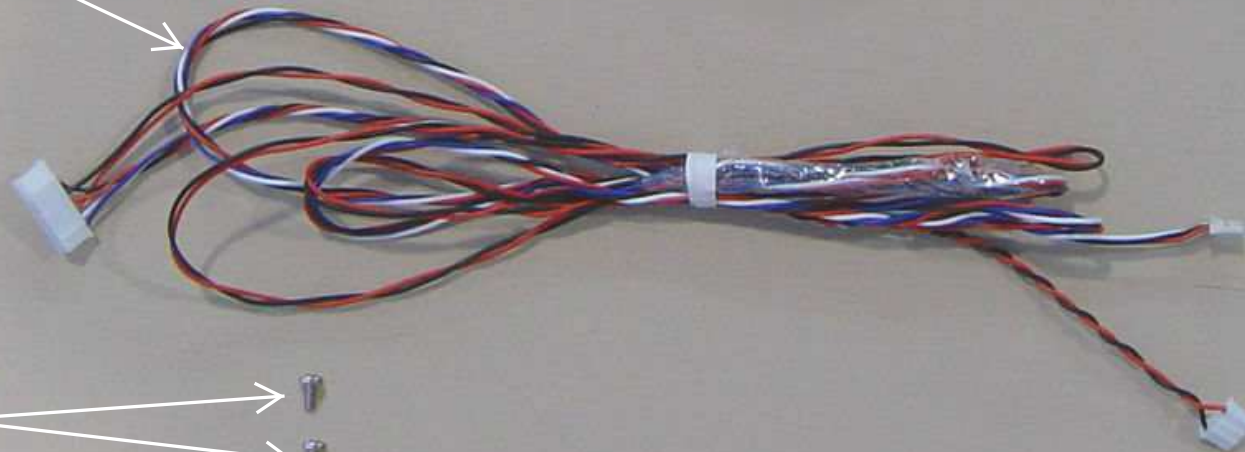

P/N.-
72031015
(2)



5.- CONNECT CABLES (COMPONENTS)

P/N.-
73100002
(4)

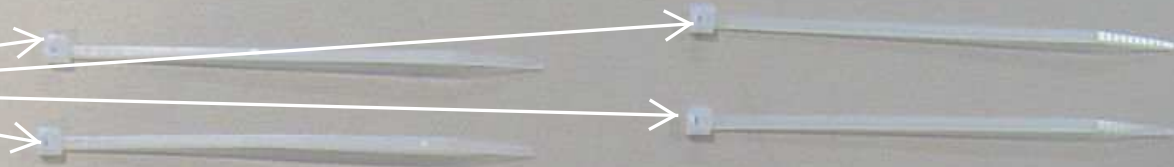

P/N.-
90114091



P/N.-
90114099



P/N.-
90114092



CONNECT
CABLE P/N.-
90113910

CONNECT
CABLE P/N.-
90114090

CONNECT
CABLE P/N.-
90114089

CONNECT
CABLE P/N.-
90114054
(SEE NEXT
PICTURE)

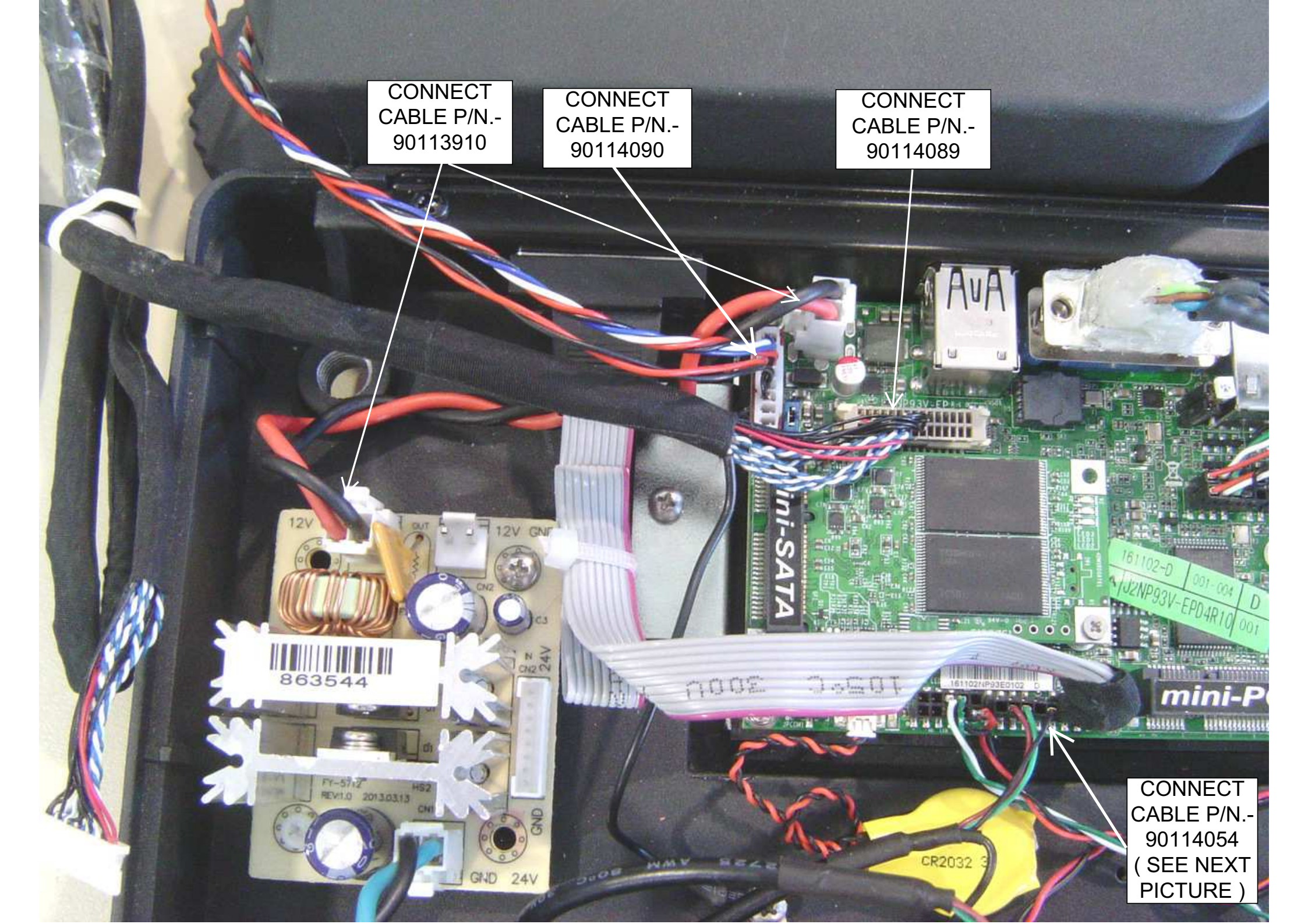

CONNECT
CABLE P/N.-
90114097

CONNECT
CABLE P/N.-
90114091

CONNECT
CABLE P/N.-
90114092

161102-D | 001-004 | D
A/J2NP93V-EPD4R10 | 001

mini-PCle

CONNECT
CABLE P/N.-
90114099

TERMINALS
WITHOUT
PINES

HOLD WITH SCREW
P/N.- 72031015
GROUND TERMINALS
OF CABLES P/N.-
90114091, P/N.-
90114097 AND P/N.-
90114099

CONNECT
CABLE P/N.-
90114098

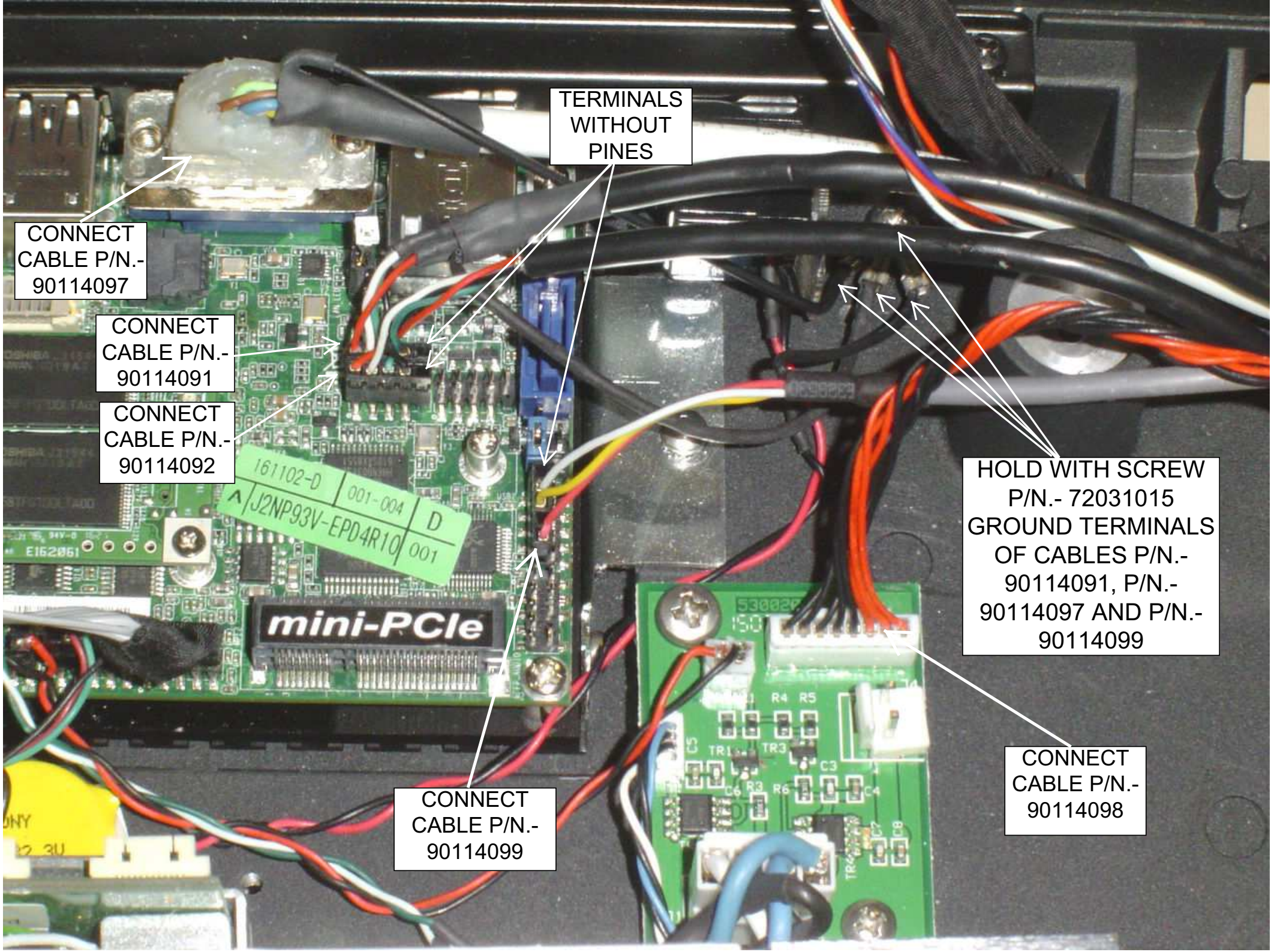

OVERVIEW

PASTE THE
STICKERS P/N.-
70000456

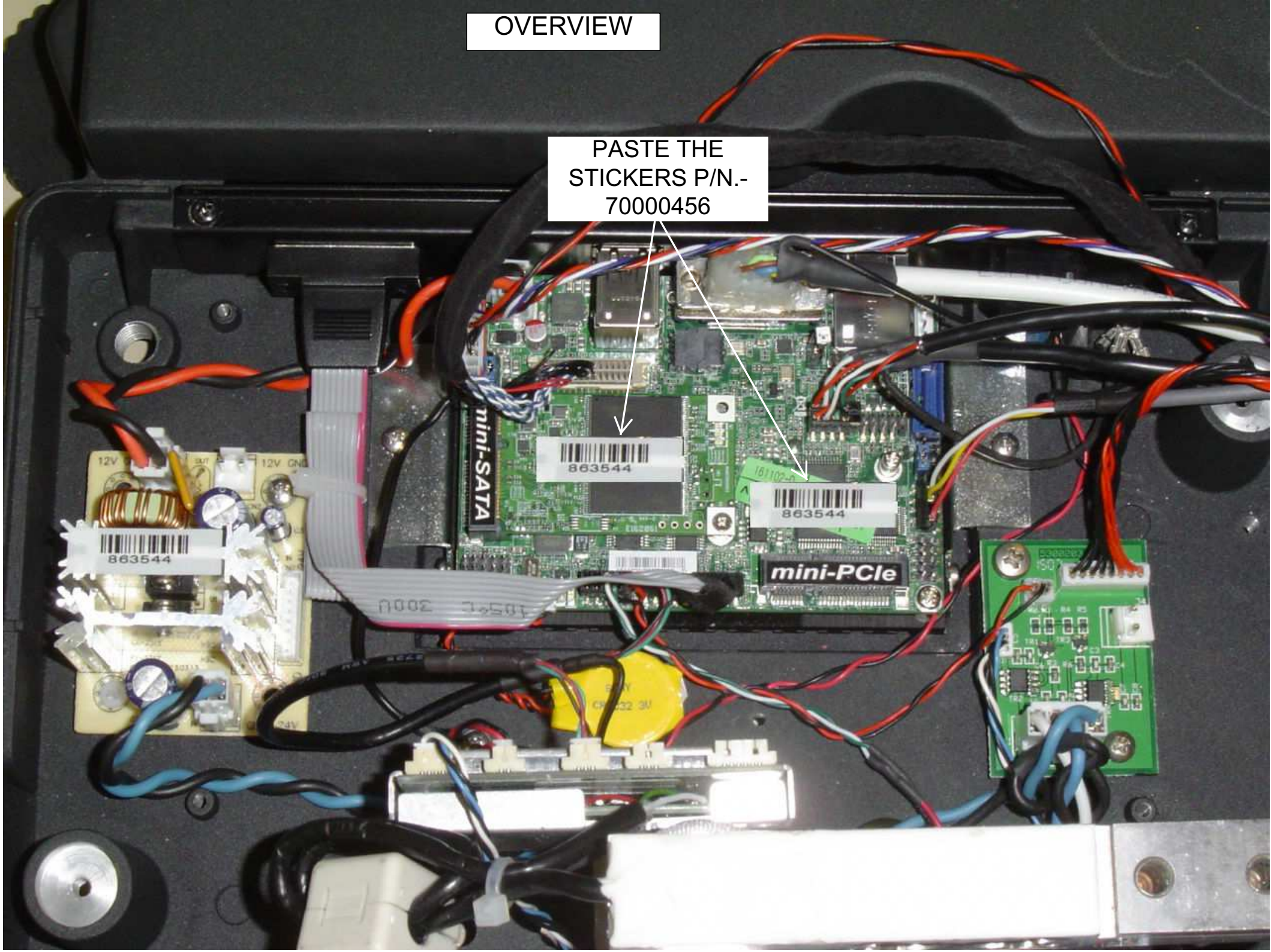

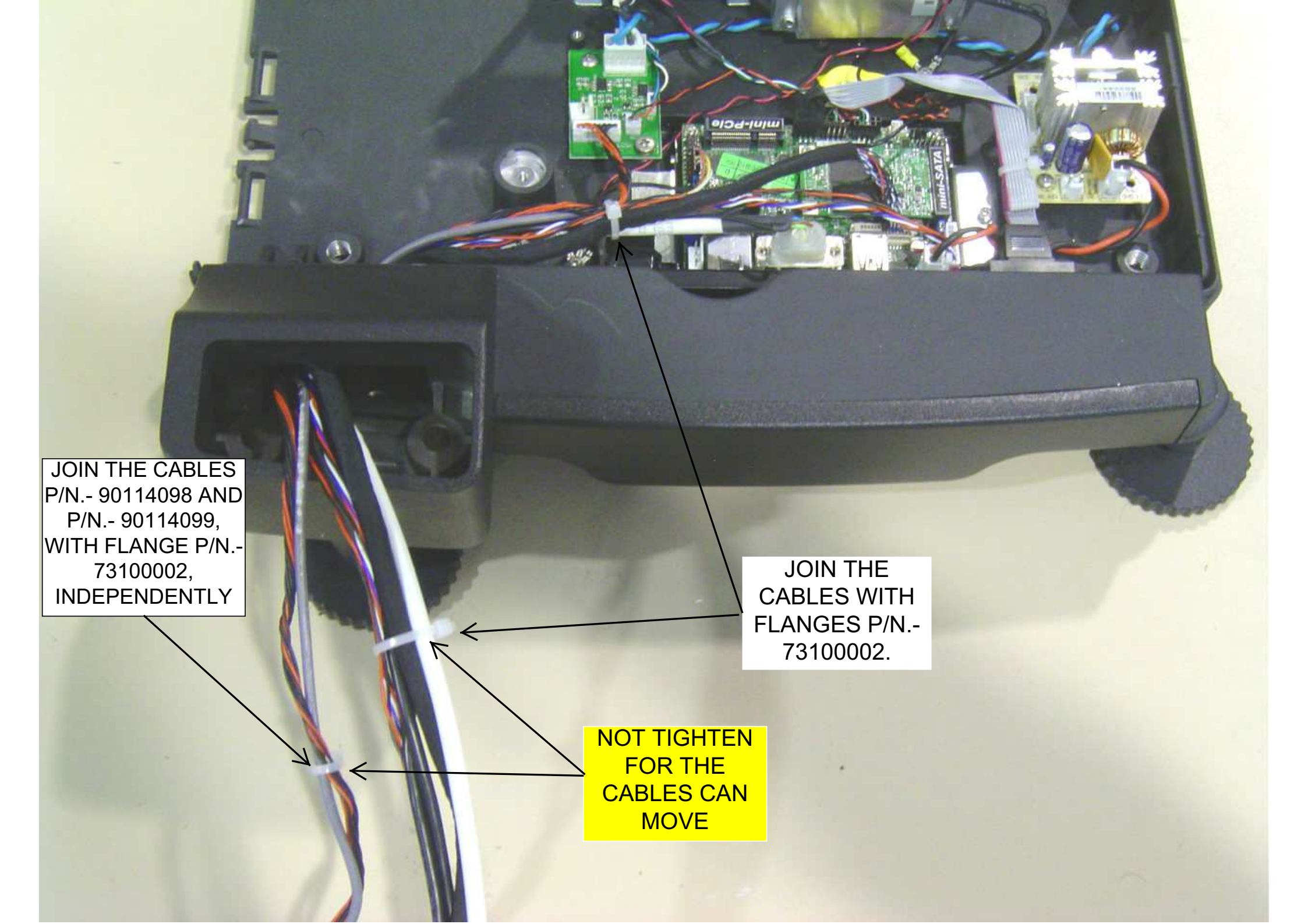

JOIN THE CABLES
P/N.- 90114098 AND
P/N.- 90114099,
WITH FLANGE P/N.-
73100002,
INDEPENDENTLY

JOIN THE
CABLES WITH
FLANGES P/N.-
73100002.

NOT TIGHTEN
FOR THE
CABLES CAN
MOVE

6.- ASSEMBLY COLUMN (COMPONENTS)



P/N.-
71002309



P/N.-
72062035
(2)



P/N.-
71000080



P/N.-
71001819

INSERT COVER RUBBER,
IN THE RIGHT POSITION,
P/N.- 71000080 IN COLUMN
P/N.- 71002309



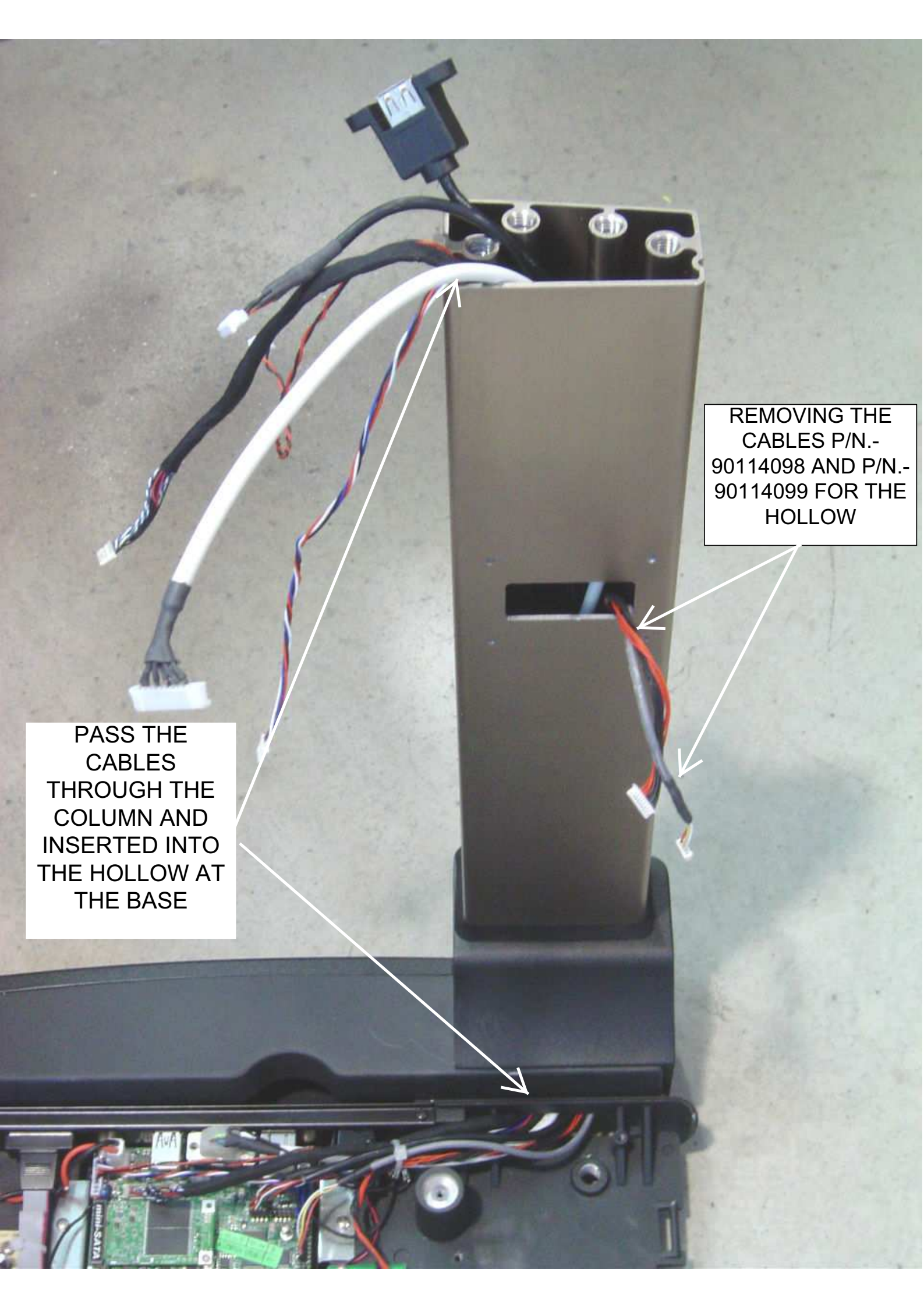

REMOVING THE
CABLES P/N.-
90114098 AND P/N.-
90114099 FOR THE
HOLLOW

PASS THE
CABLES
THROUGH THE
COLUMN AND
INSERTED INTO
THE HOLLOW AT
THE BASE

HOLD THE COLUMN WITH 2 SCREWS P/N.-
72062035. TIGHTEN WITH A REGULATED TOOL
TO A TIGHTENING TORQUE 11 Nm

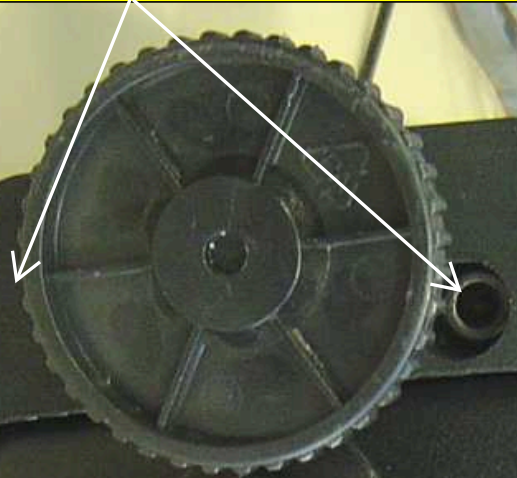

TO PUT COVER P/N.-
71001819



7. ASSEMBLY COVER (COMPONENTS)

P/N.- 71004341



P/N.-
79000015



P/N.- 71000055 (3)



P/N.- 72031026 (3)

P/N.-
71004435

P/N.- 71004341

P/N.- 79000015

P/N.- 72031026
(3)

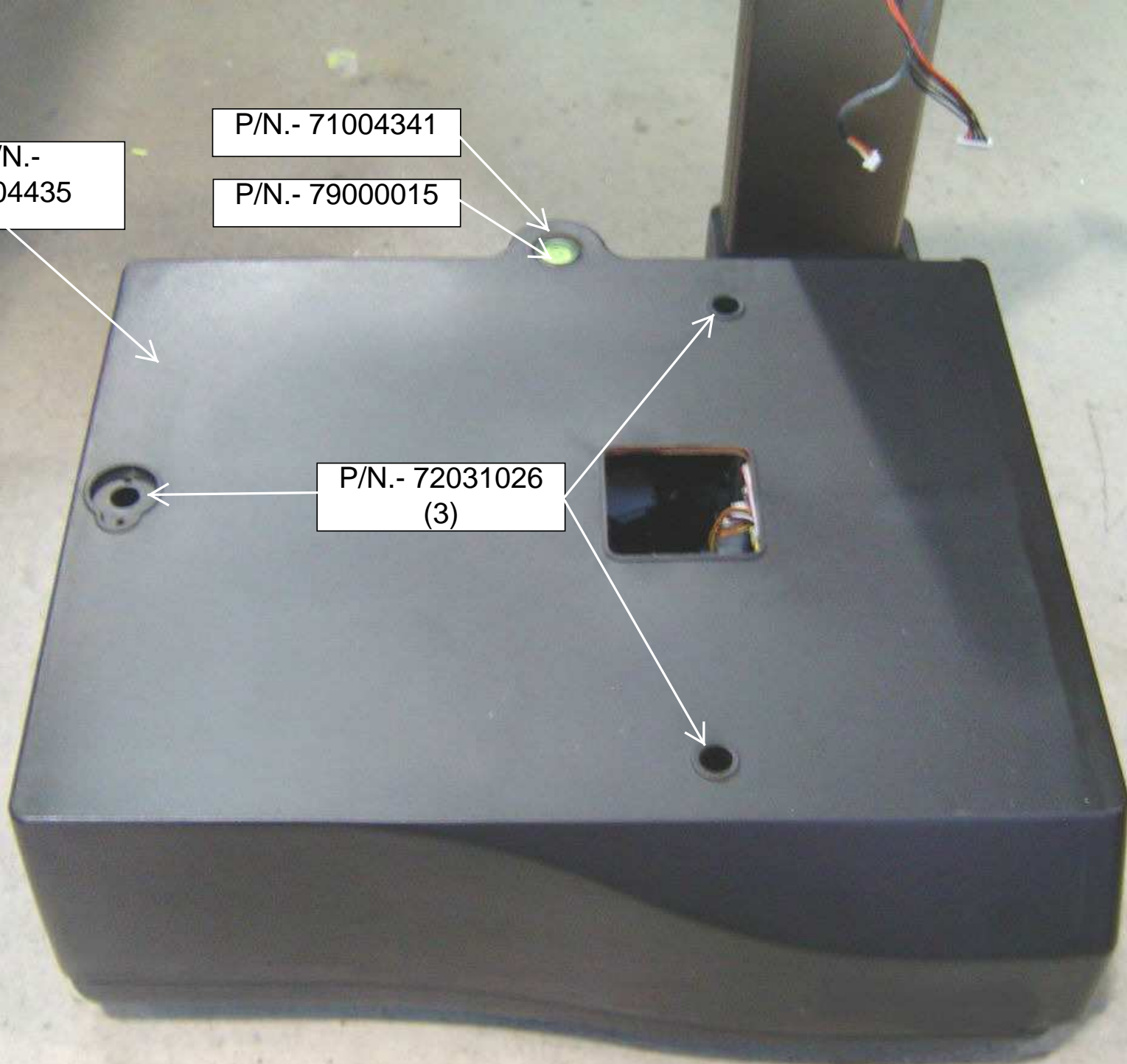

PUT THE
RUBBER
STOPPERS P/N.-
71000055



8.- ASSEMBLY UP CROSS AND PUT PAN SCALE (COMPONENTS)

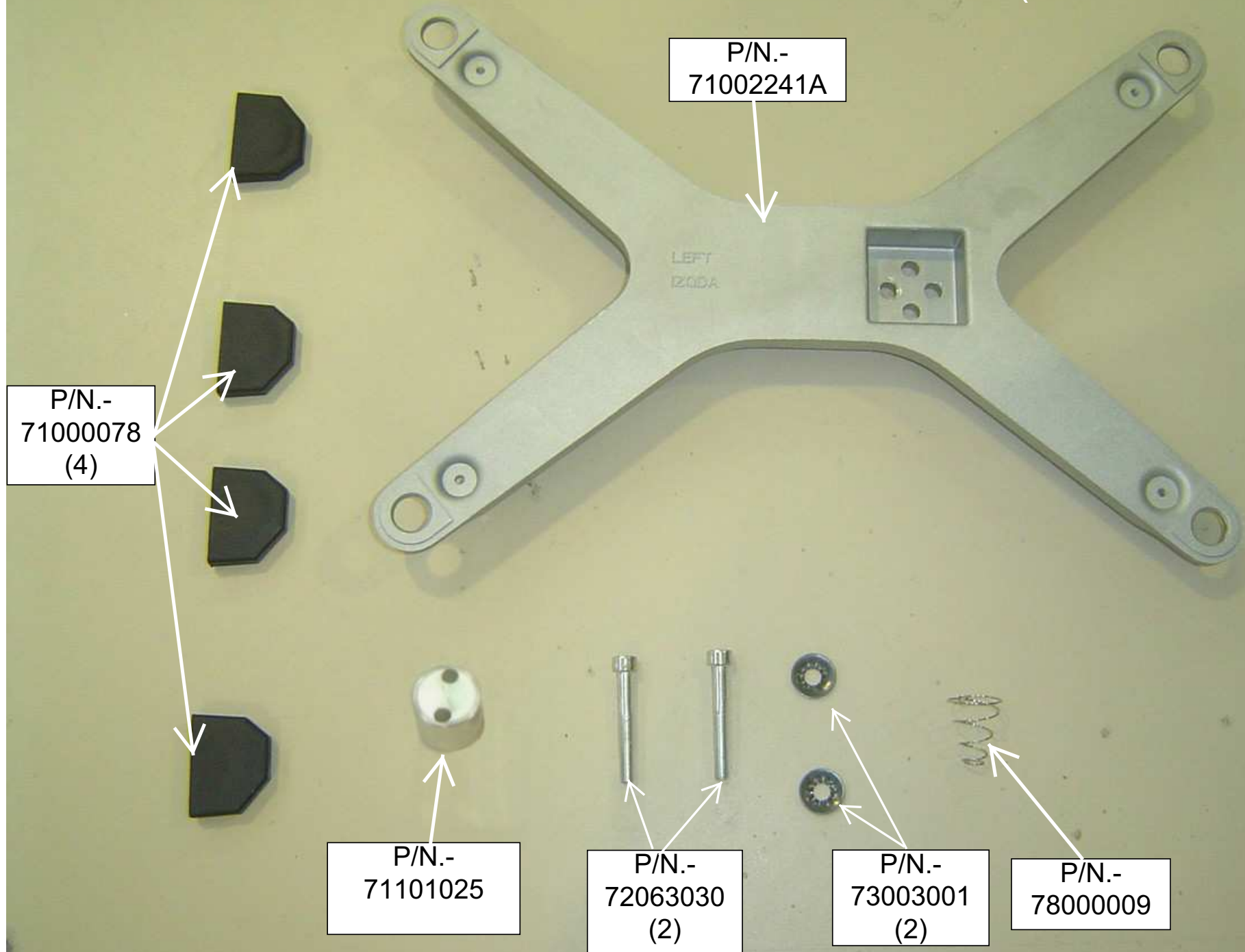

PUT THE
SPACER P/N.-
71101025



P/N.-
71002241A

P/N.- 73003001

P/N.-
71000078

PUT THE SPRING
P/N.- 78000009
HOLDING WITH
THE WHASER
AND THE SCREW

P/N.-
72063030

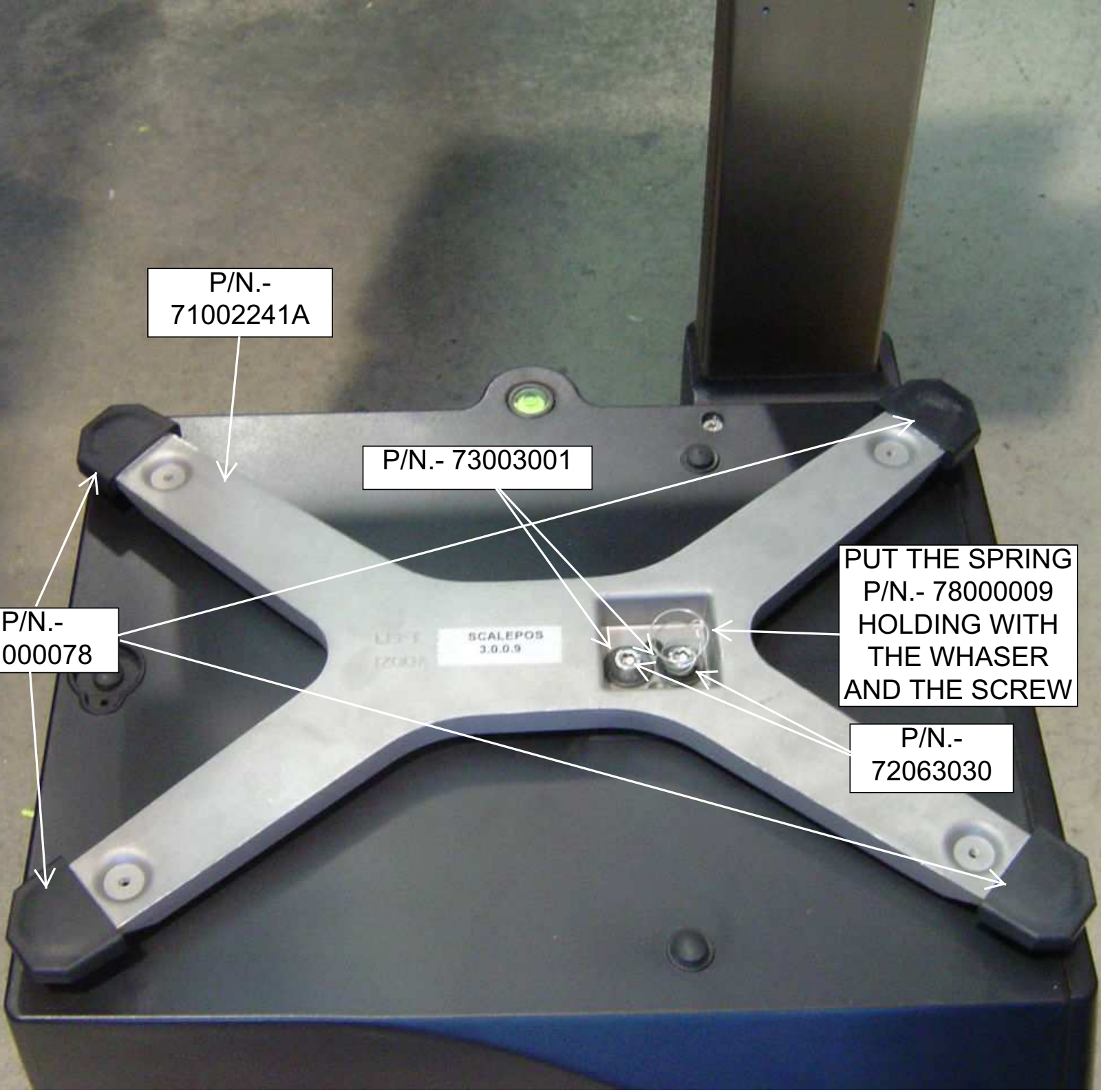

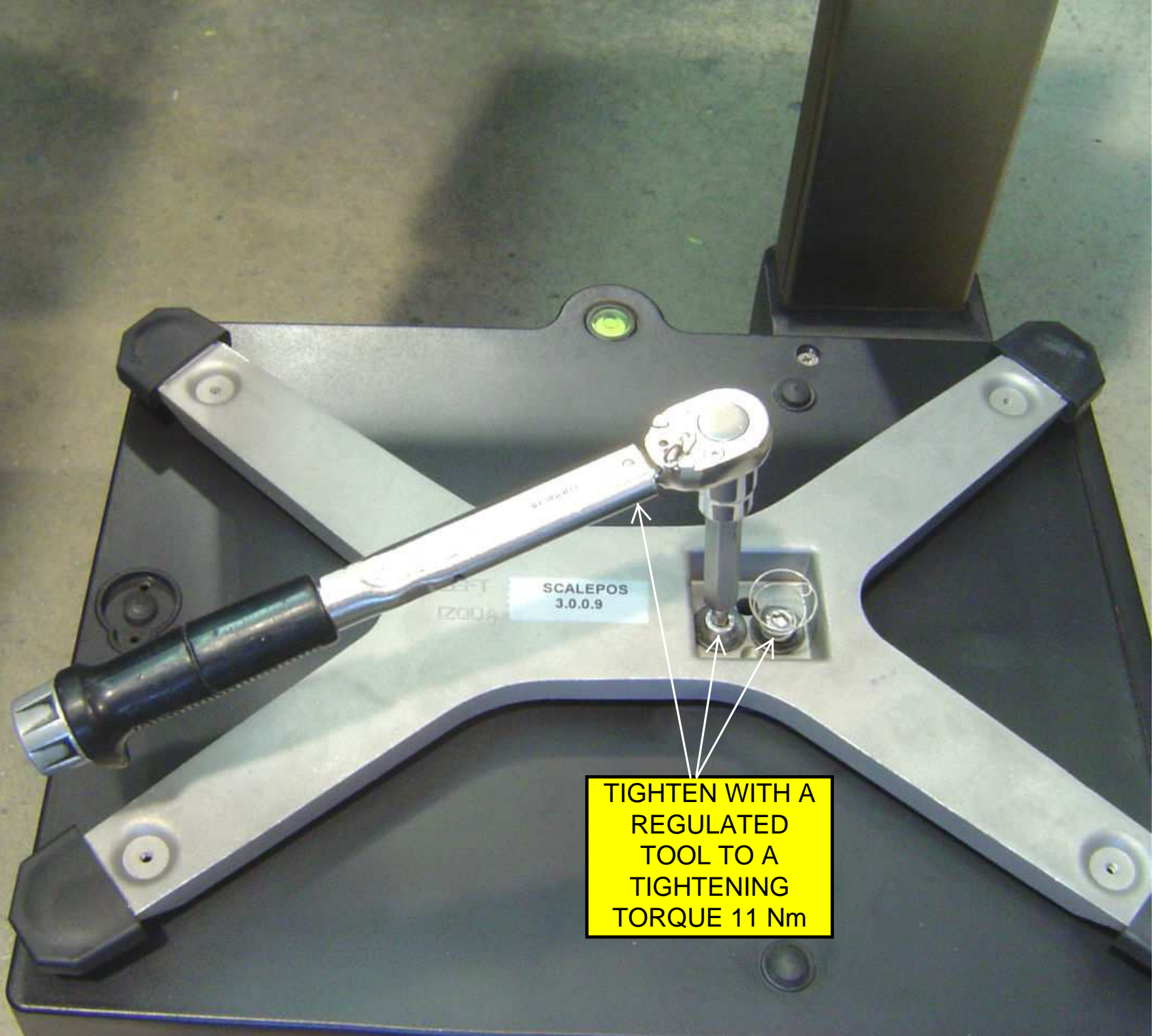

TIGHTEN WITH A
REGULATED
TOOL TO A
TIGHTENING
TORQUE 11 Nm

PUT THE PAN
SCALE P/N.-
71210246



9.- ASSEMBLY SUPPORT OF MONITORS (COMPONENTS)

P/N.-
72190004
(4)

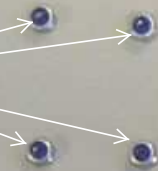

P/N.-
19087300



P/N.-
71000075



P/N.-
71100003
(4)

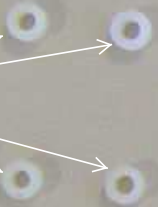

P/N.-
19087500



P/N.-
72054017
(2)



P/N.-
90114093



P/N.-
72062035
(2)



P/N.-
90114094



9.- ASSEMBLY SUPPORT OF MONITORS (COMPONENTS)

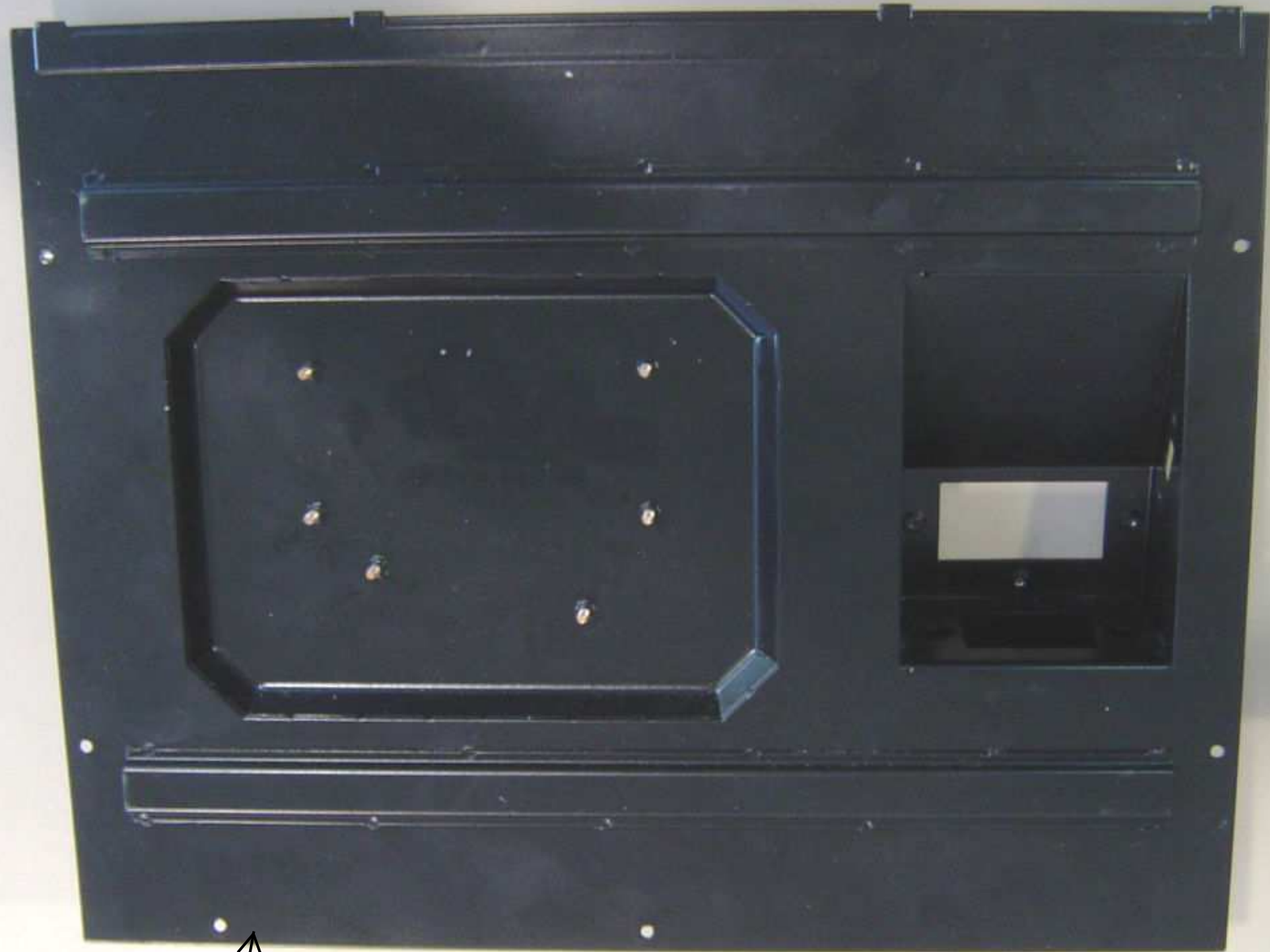

P/N.-
71210588

PASTE THE PIECE P/N.- 71000075
DOWN BOARD 19087500

HOLD THE BOARD P/N.-
19087500 WITH 2 NUTS P/N.-
72190004

CONNECT THE CABLE
P/N.- 90114093 AT
THIS POSITION AND
HOLD THE GROUND
TERMINAL WITH NUT

CONNECT THE
CABLE P/N.-
90114094

HOLD THE BOARD P/N.-
19087300 WITH 2 NUTS P/N.-
72190004

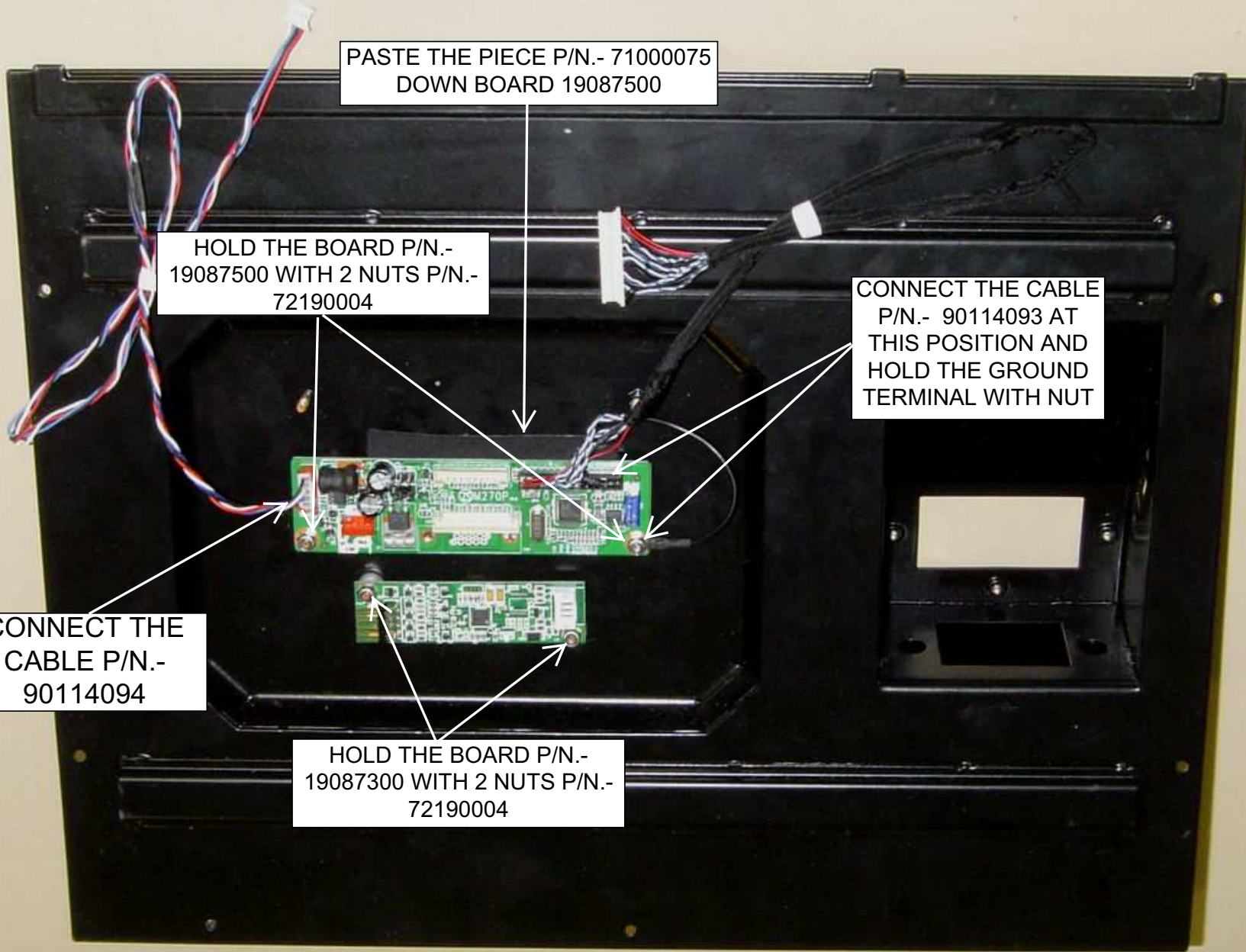

CONNECT
THE CABLE
P/N.-
90114097

HOLD THE CABLE
P/N.- 90114091
WITH 2 SCREWS
P/N.- 72054017
(SEE NEXT
PICTURE)

CONNECT THE CABLE
P/N.- 90114090

HOLD THE
PIECE P/N.-
71210588 WITH 2
SCREWS P/N.-
72062035
TIGHTEN WITH A
REGULATED
TOOL TO A
TIGHTENING
TORQUE 11 Nm

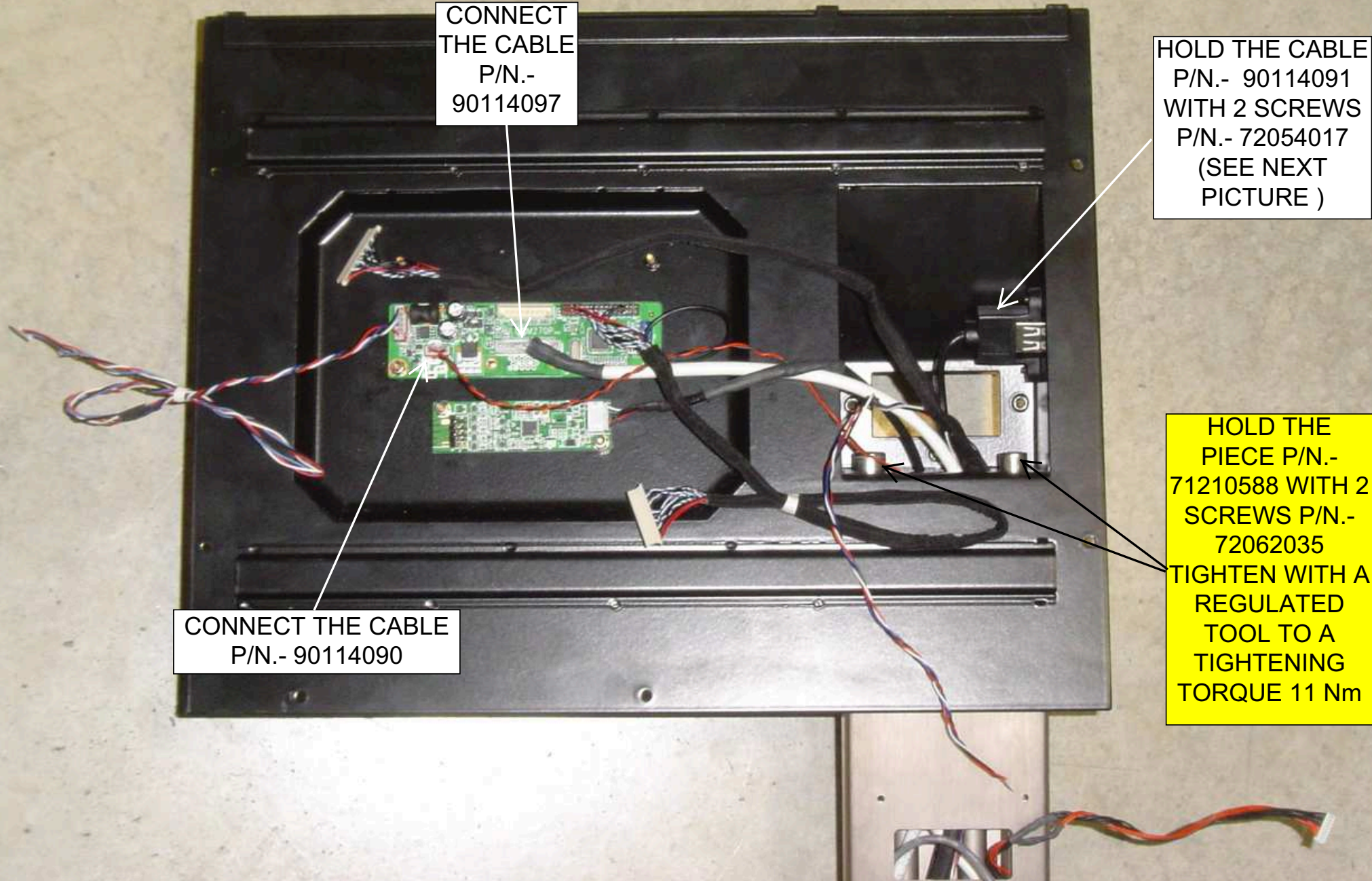

HOLD THE PIECE P/N.- 71210588
WITH 2 SCREWS P/N.- 72062035
TIGHTEN WITH A REGULATED
TOOL TO A TIGHTENING TORQUE
11 Nm

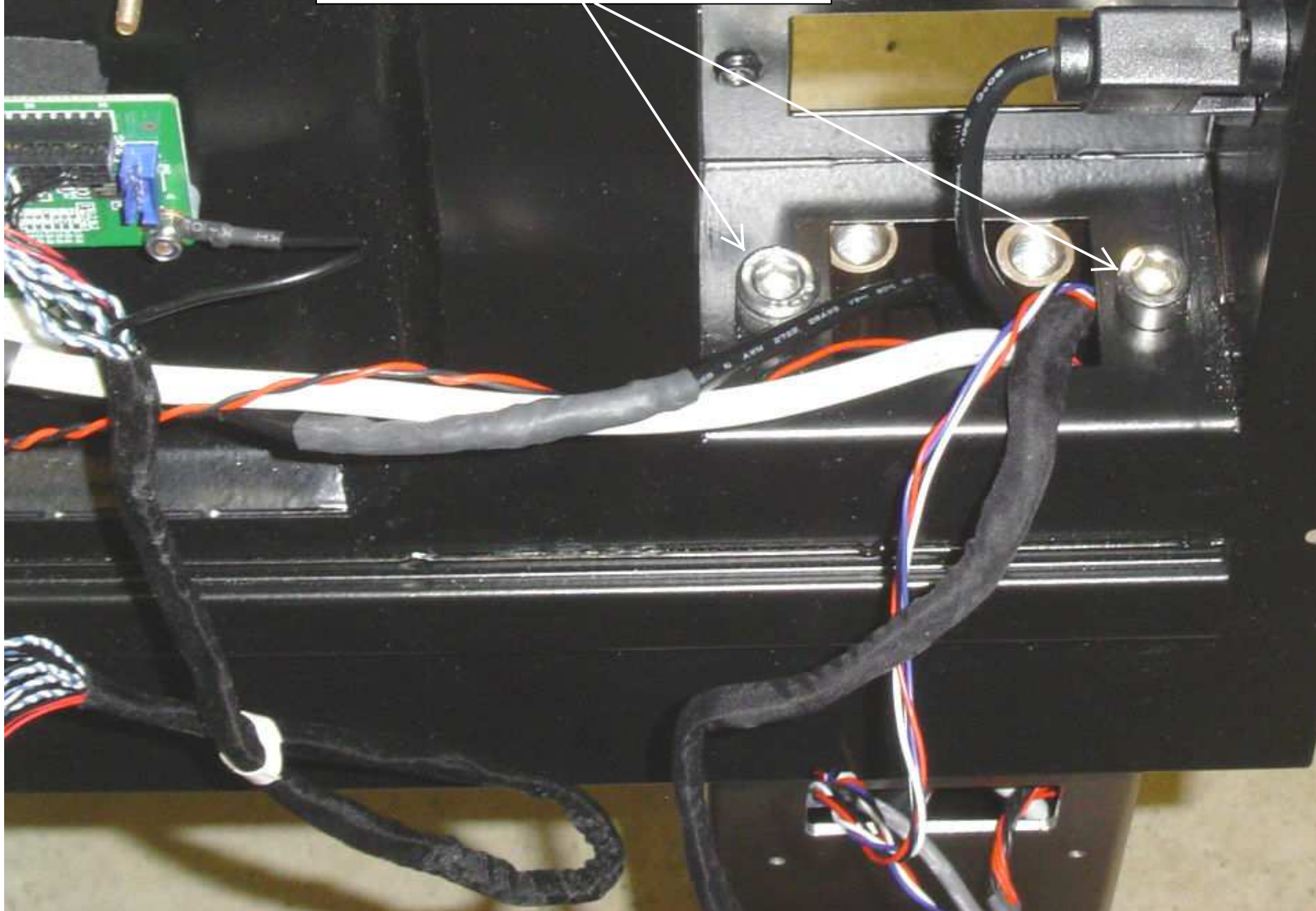

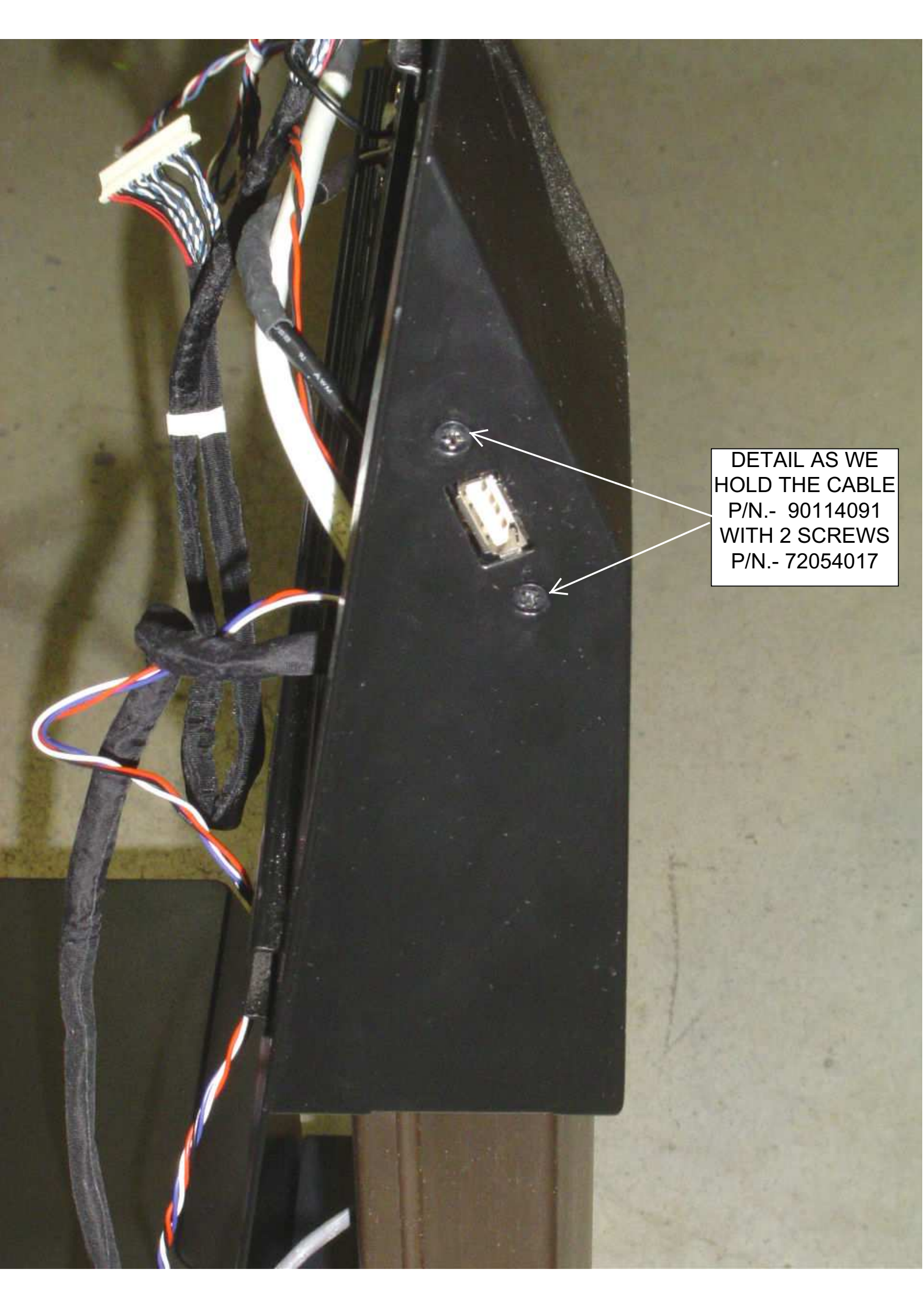

DETAIL AS WE
HOLD THE CABLE
P/N.- 90114091
WITH 2 SCREWS
P/N.- 72054017

10.- ASSEMBLY 15" FRONT MONITOR (COMPONENTS)



P/N.-
71210523 (2)

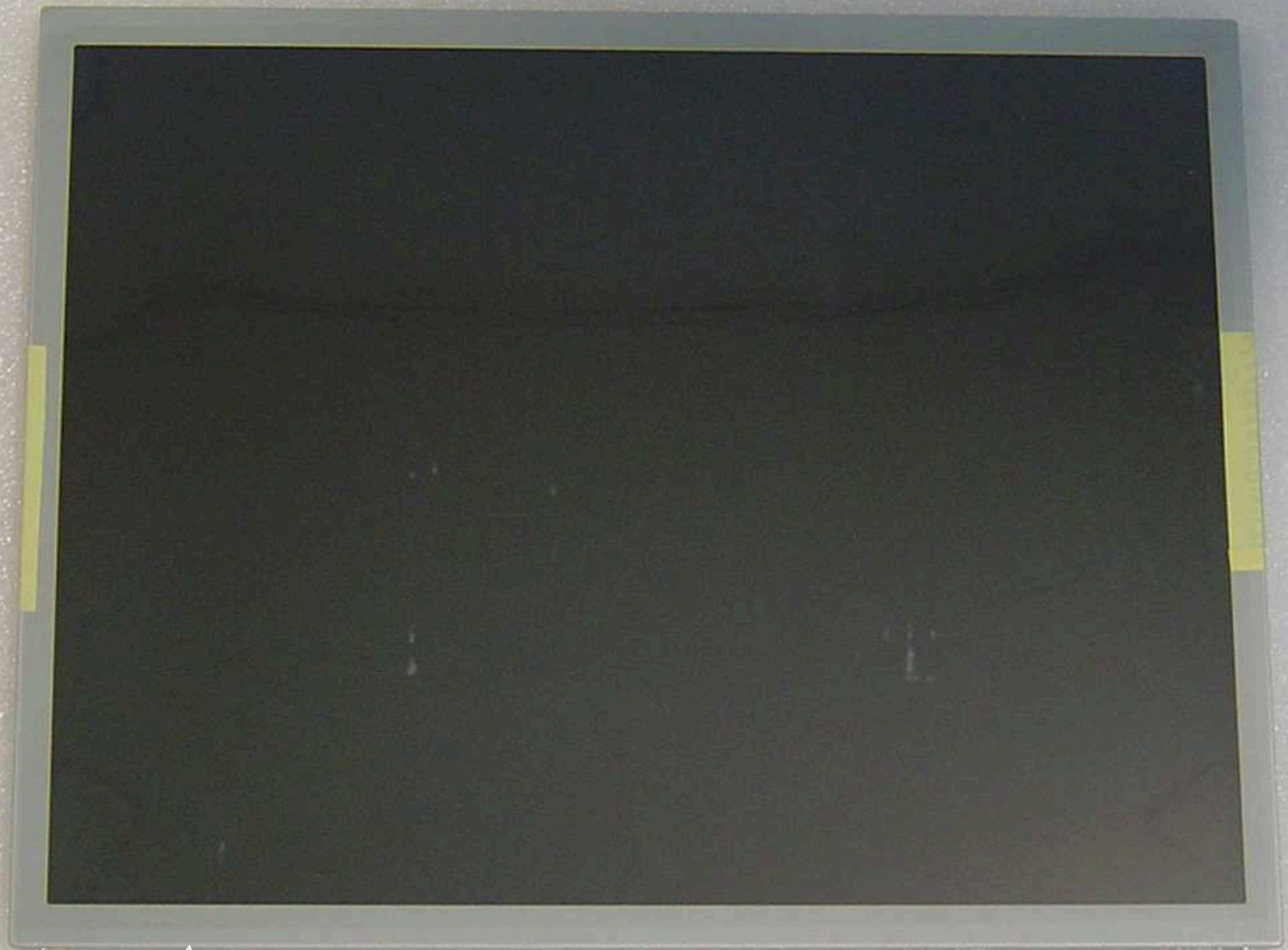

P/N.-
19017600



P/N.- 72200009
(3 mm)(4)



P/N.- 72031015
(4)

10.- ASSEMBLY 15" FRONT MONITOR (COMPONENTS)



P/N.- 72201011 (4 mm)
(8)



P/N.- 72056007
(8)



P/N.- 72054017
(6)

10.- ASSEMBLY 15" FRONT MONITOR (COMPONENTS)

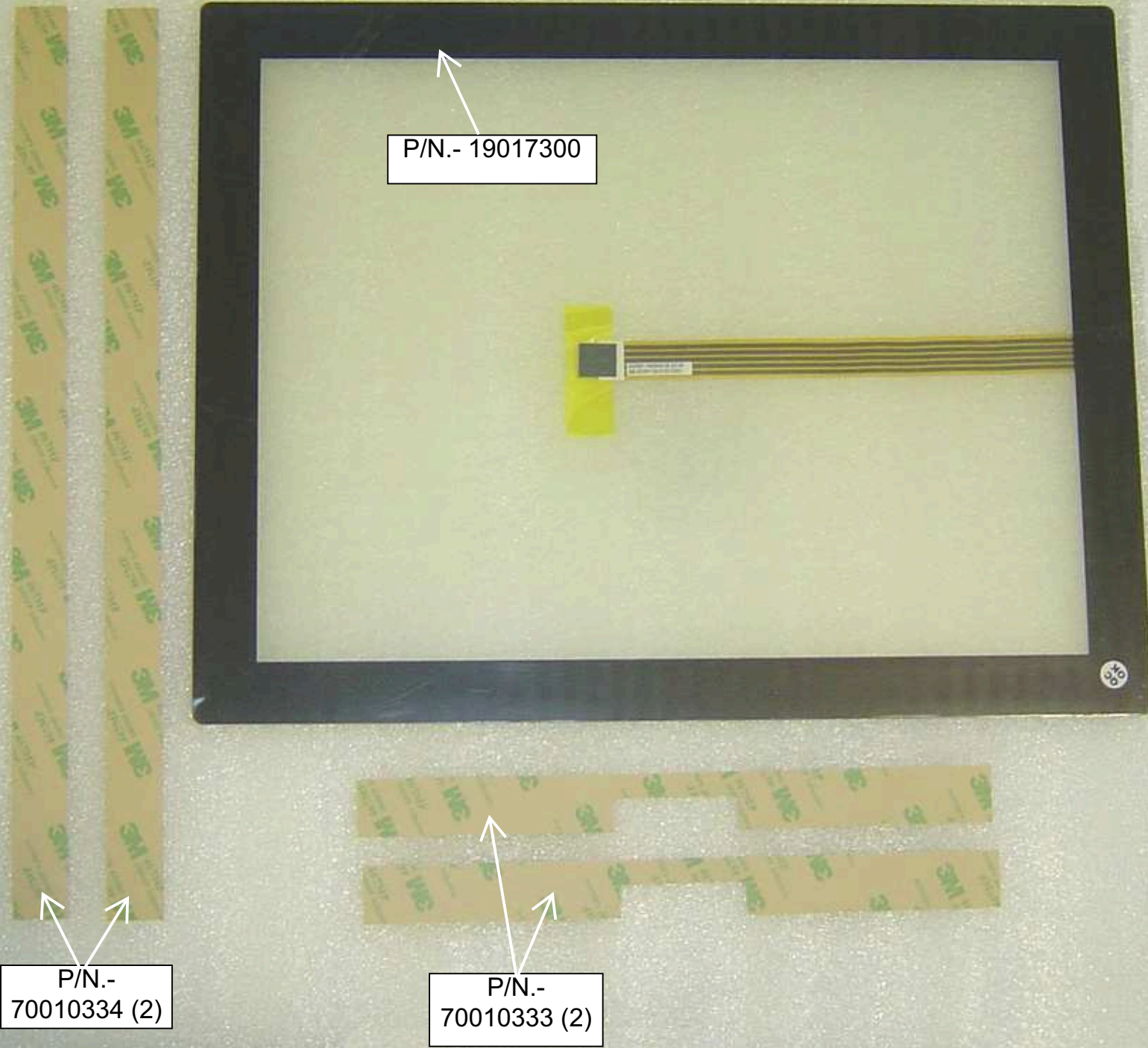

P/N.- 19017300

P/N.-
70010334 (2)

P/N.-
70010333 (2)

PUT THE
MONITOR
SUPPORT IN
LINE WITH THE
SAME



HOLD THE MONITOR SUPPORT
WITH WASHERS P / N.- 72200009
AND SCREWS P / N.- 72031015



VIEW OTHER SIDE OF
MONITOR

PUT THE
MONITOR
SUPPORT IN
LINE WITH THE
SAME

HOLD THE MONITOR SUPPORT
WITH WASHERS P / N.- 72200009
AND SCREWS P / N.- 72031015



ASSEMBLY VIEW

REMOVE THE
MONITOR PROTECTOR
BEFORE PUTTING IT
ON THE SUPPORT

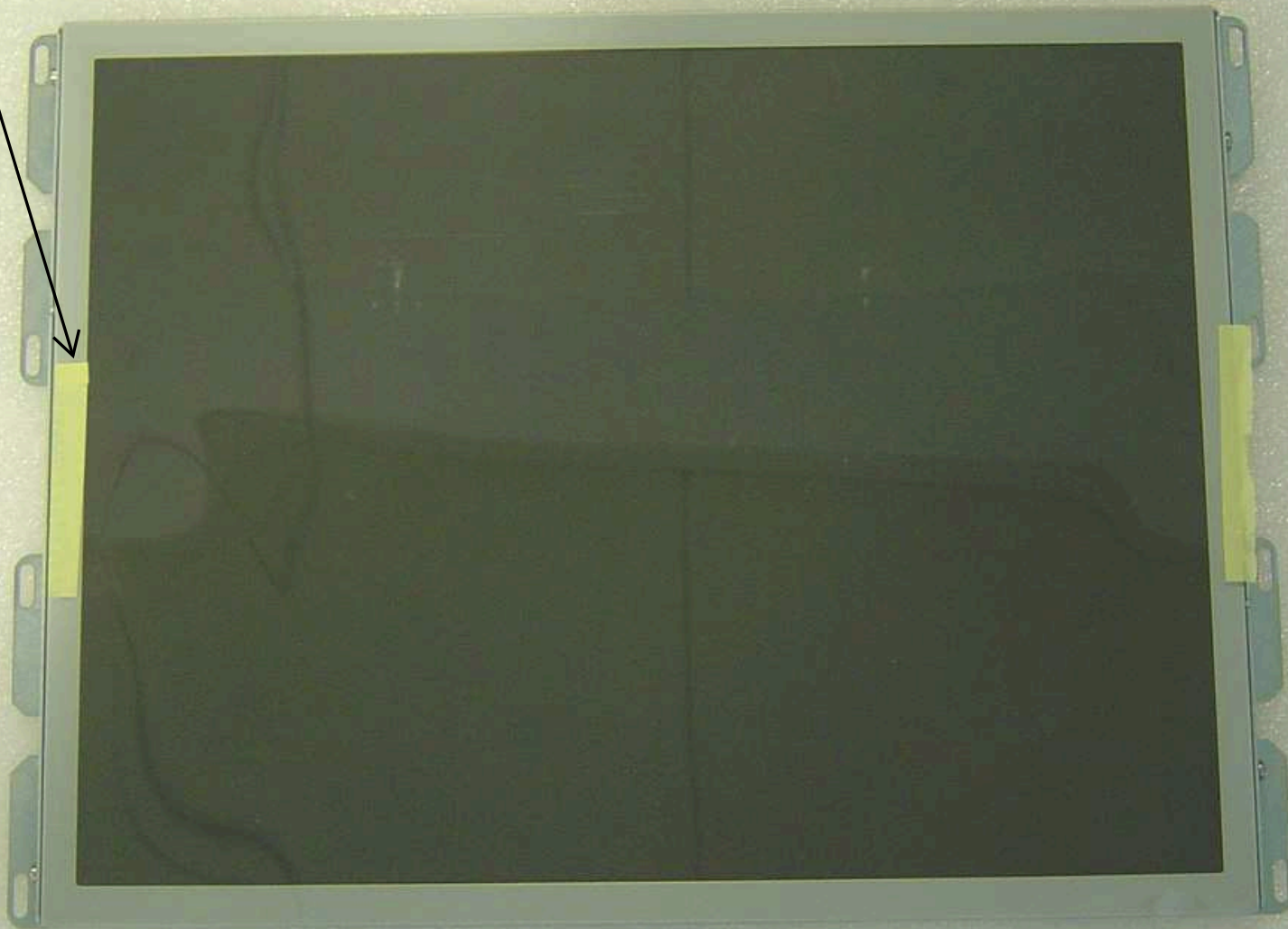

PUT THE MONITOR IN THIS POSITION. LOW TOWERS

HOLD IT WITH 8 WASHERS P / N.- 72201011 AND 8 SCREWS P / N.- 73036007. BEFORE TIGHTEN THE SCREWS BE SURE THE MONITOR IS CENTERED AND THE PLATED BORDERS ARE NOT VIEWED ON THE VISION WINDOW (SEE NEXT IMAGE)

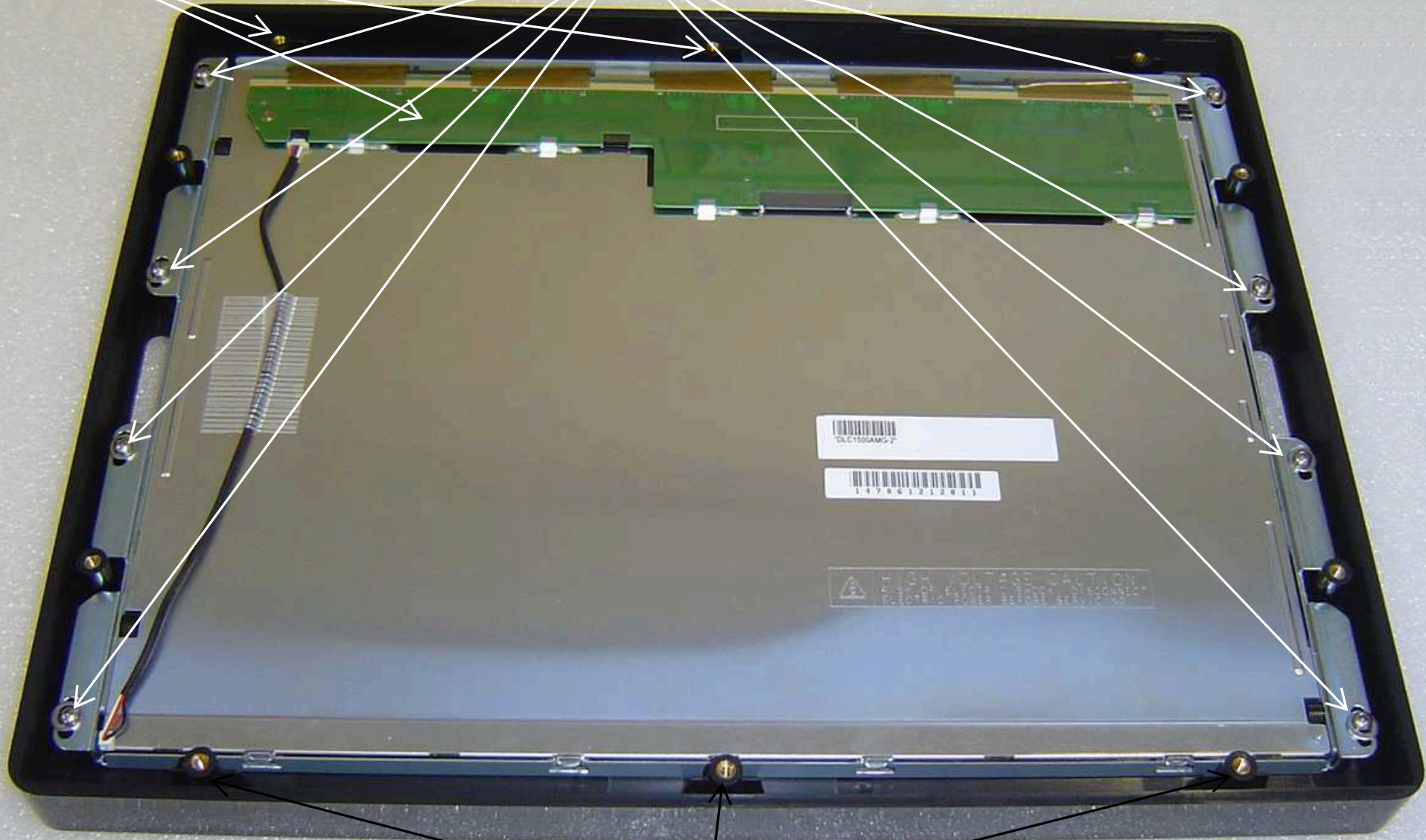

HIGH TOWERS SUPPORT

CENTERING THE
MONITOR TO PREVENT
THE VIEW OF THE
PLATED EDGE

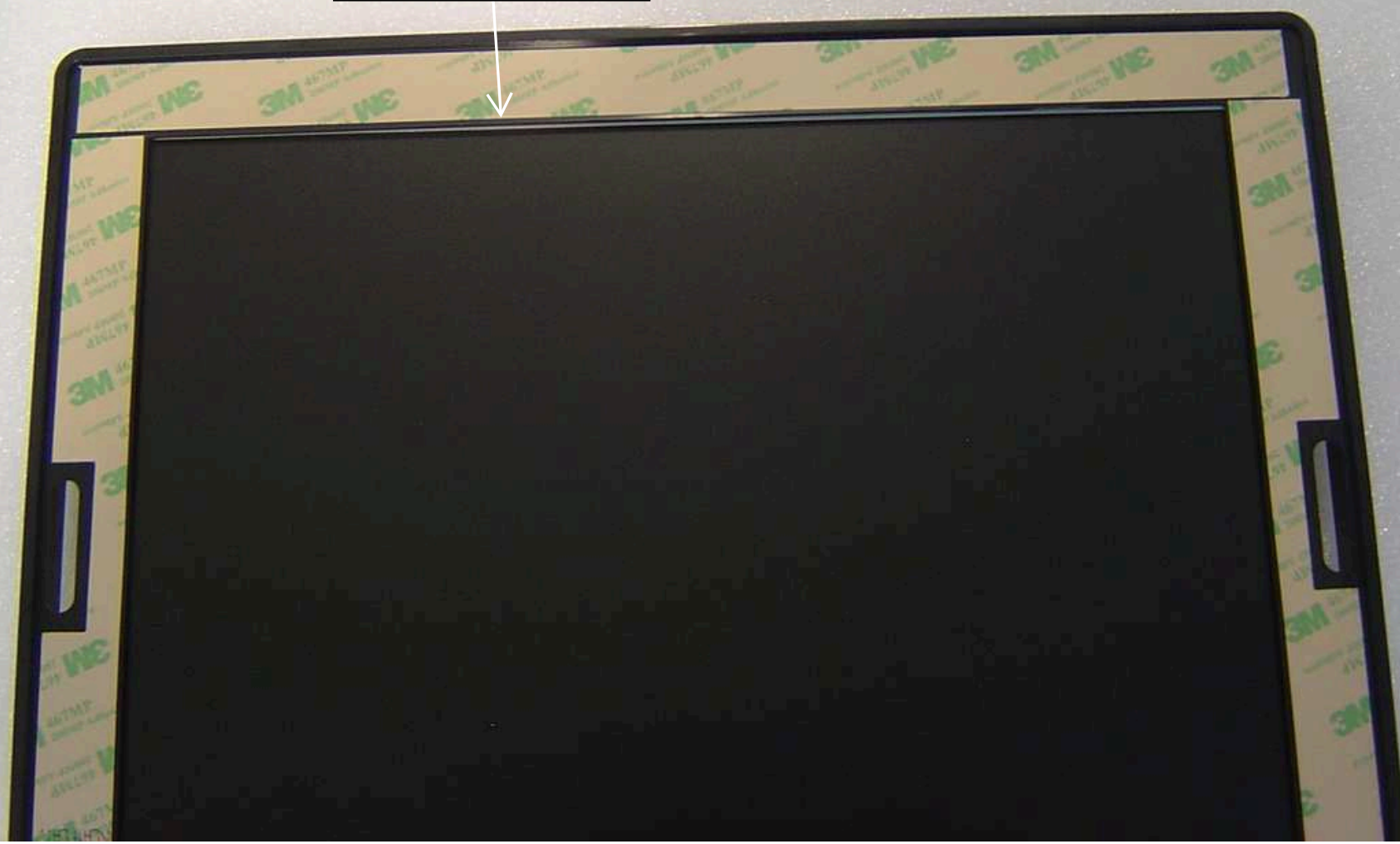

TIGHTEN THE ADHESIVE STRIPS P / N.-
70010333 AND 70010334 TO THE
MONITOR HOUSING . ALSO REMOVE THE
PROTECTOR OF THE EXTERNAL PART TO
PICK THE TOUCH

P/N.-
70010334

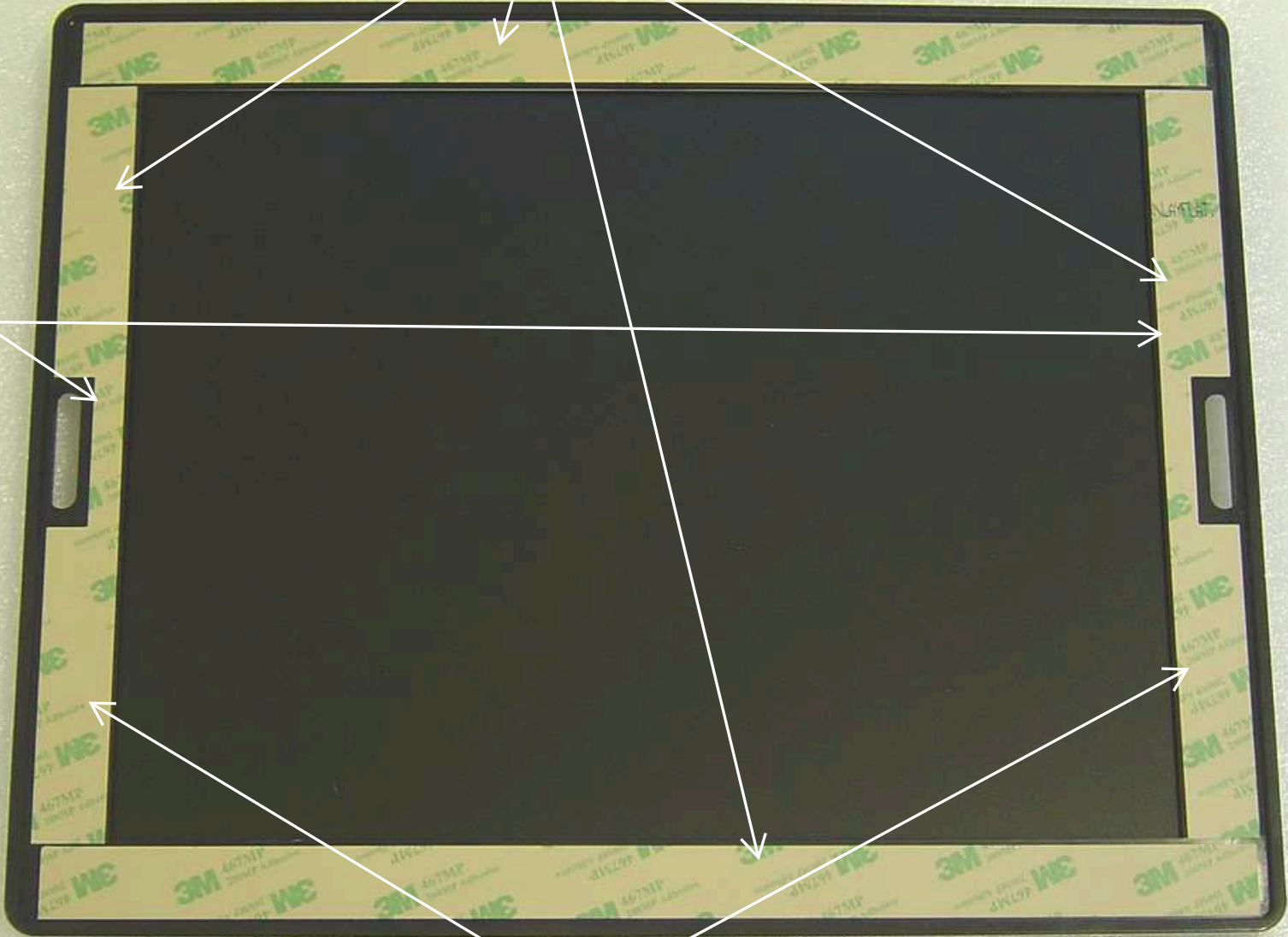

P/N.-
70010333

OVERVIEW



REMOVE THE TOUCH INTERNAL PROTECTOR BEFORE PICKING IT

INSERT THE TOUCH IN THE SPACE OF THE CASE AND PLACE IT IN THE ADHESIVE TAPES. INSERT THE CABLE BY THE HOLLOW OF THE LEFT PART



OVERVIEW BACK
SIDE

TOUCH
CABLE

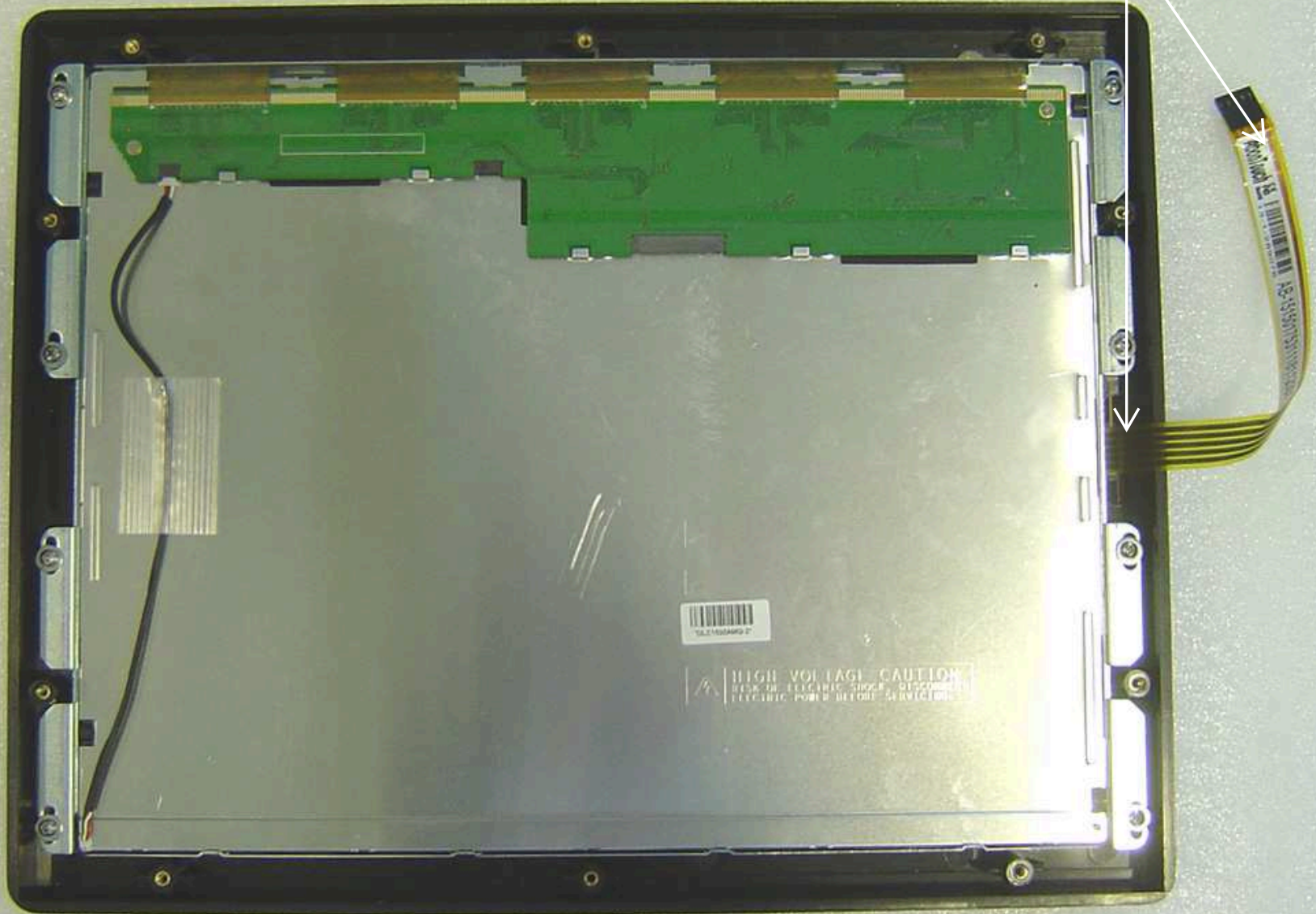

UL2168480 0

⚠ HIGH VOLTAGE CAUTION
RISK OF ELECTRIC SHOCK. DISCONNECT
ELECTRIC POWER BEFORE SERVICING.

CONNECT THE TOUCH CABLE, AT THIS POSITION, IN UP PINES

HOLD THE CABLES WITH FLANGE

PASS THE CABLES P/N.- 90114093 AND P/N.- 90114094 THROUGH THE HOLE

CONNECT THE CABLE P/N.- 90114089

CONNECT THE CABLE P/N.- 90114090

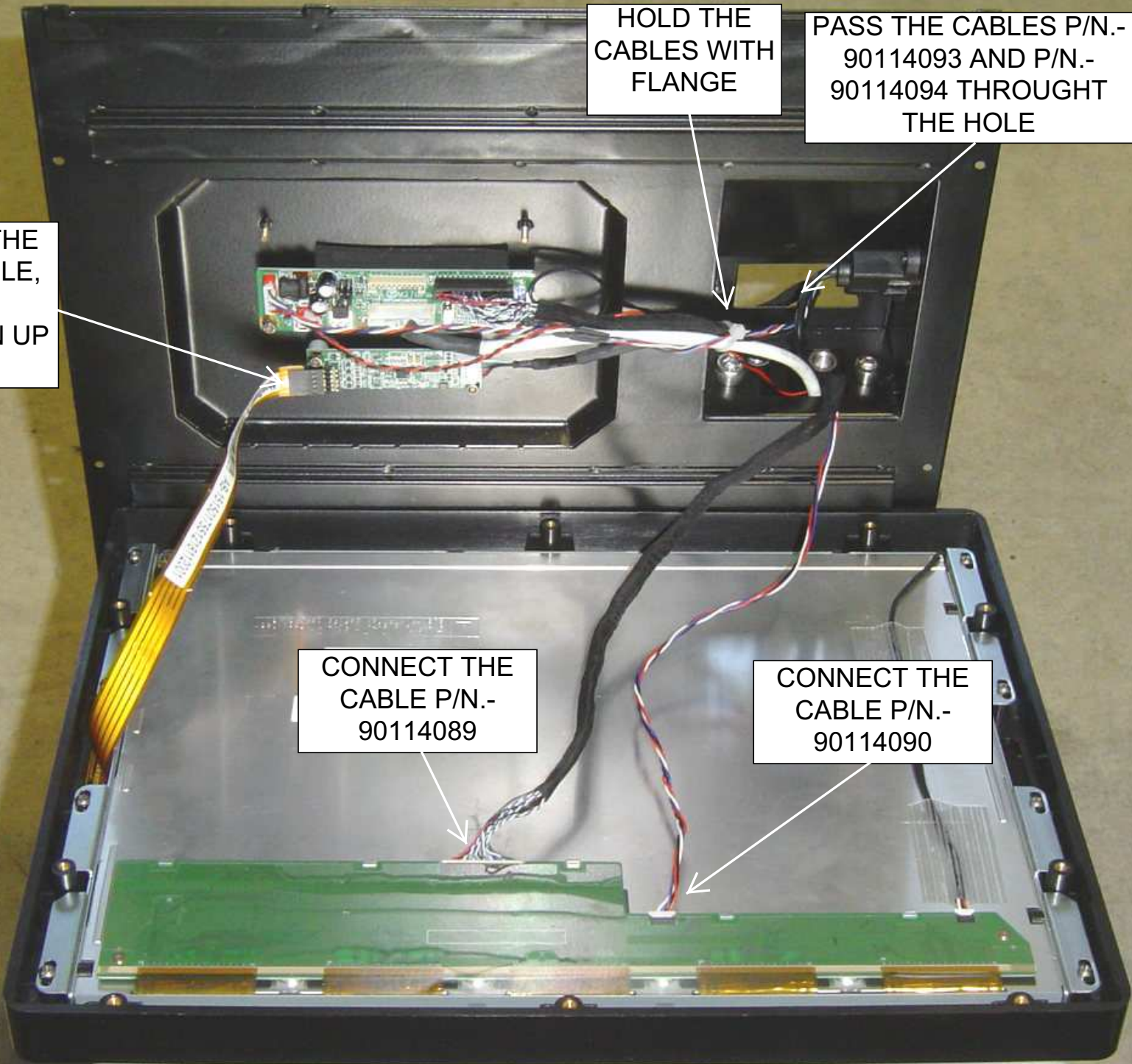

INSERT IN TABS

INSERT THE TOP OF THE MONITOR SUPPORT TO THE TABS AND AFTER HOLD THE SUPPORT WITH 6 SCREWS P/N.-72054017

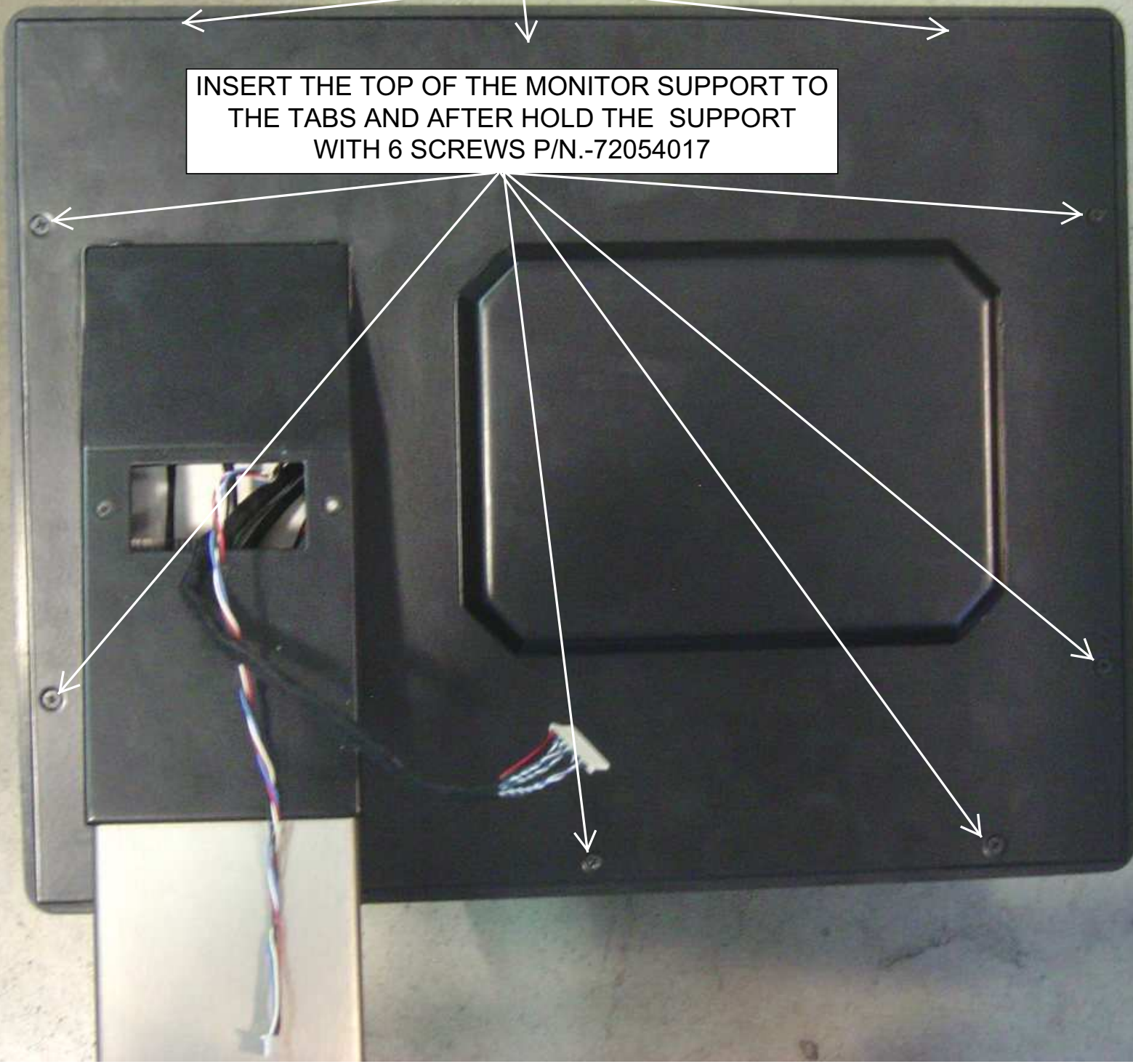

12.- ASSEMBLY SUPPORT BACK MONITOR (COMPONENTS)

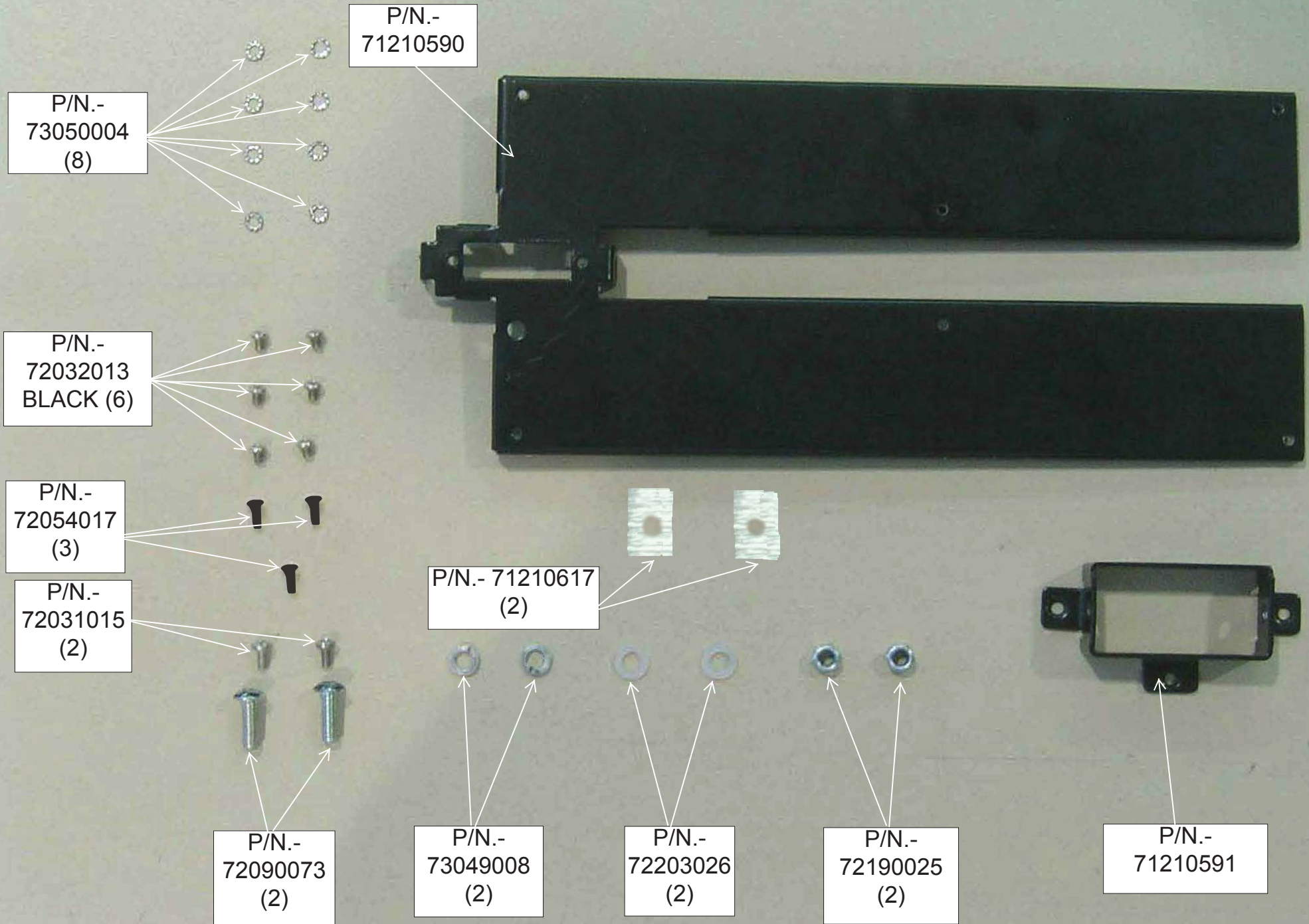

12.- ASSEMBLY SUPPORT BACK MONITOR (COMPONENTS)

P/N.-
71210592

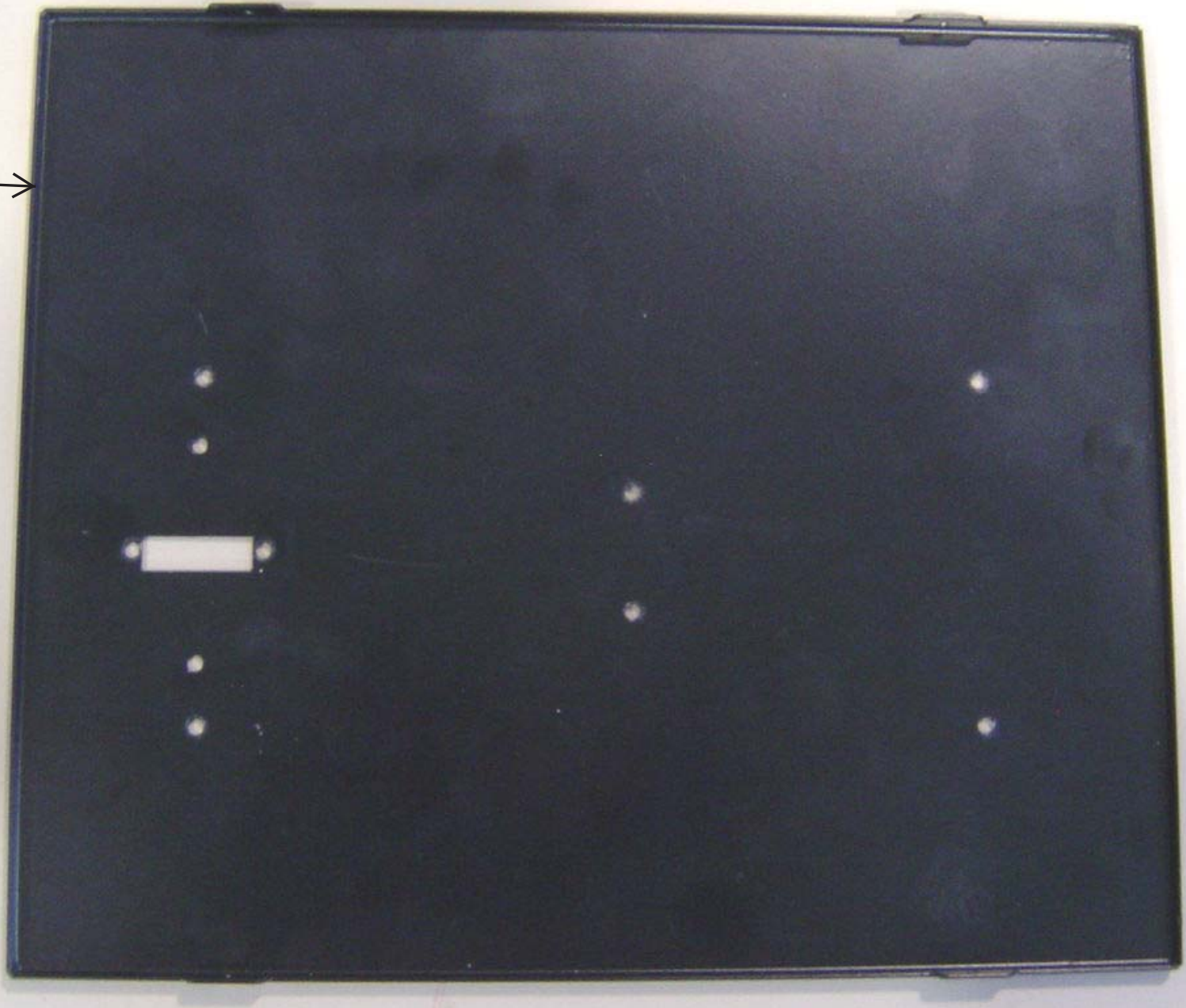

ASSEMBLY THE PIECES P/N.- 71210591 AND P/N.- 71210617 ON
PIECE P/N.- 71210590 AND HOLD WITH SCREWS P/N.- 72090073,
WHASERS P(N.- 73049008 AND 72203026 AND NUTS 72190025
(SEE NEXT PICTURES TO VIEW THE POSITION THIS PIECES)



PIECES P/N.-
71210617

DETAIL OF POSITION OF
PIECES P/N.- 71210617

WHASERS
P/N.-
73049008

P/N.-
72190025

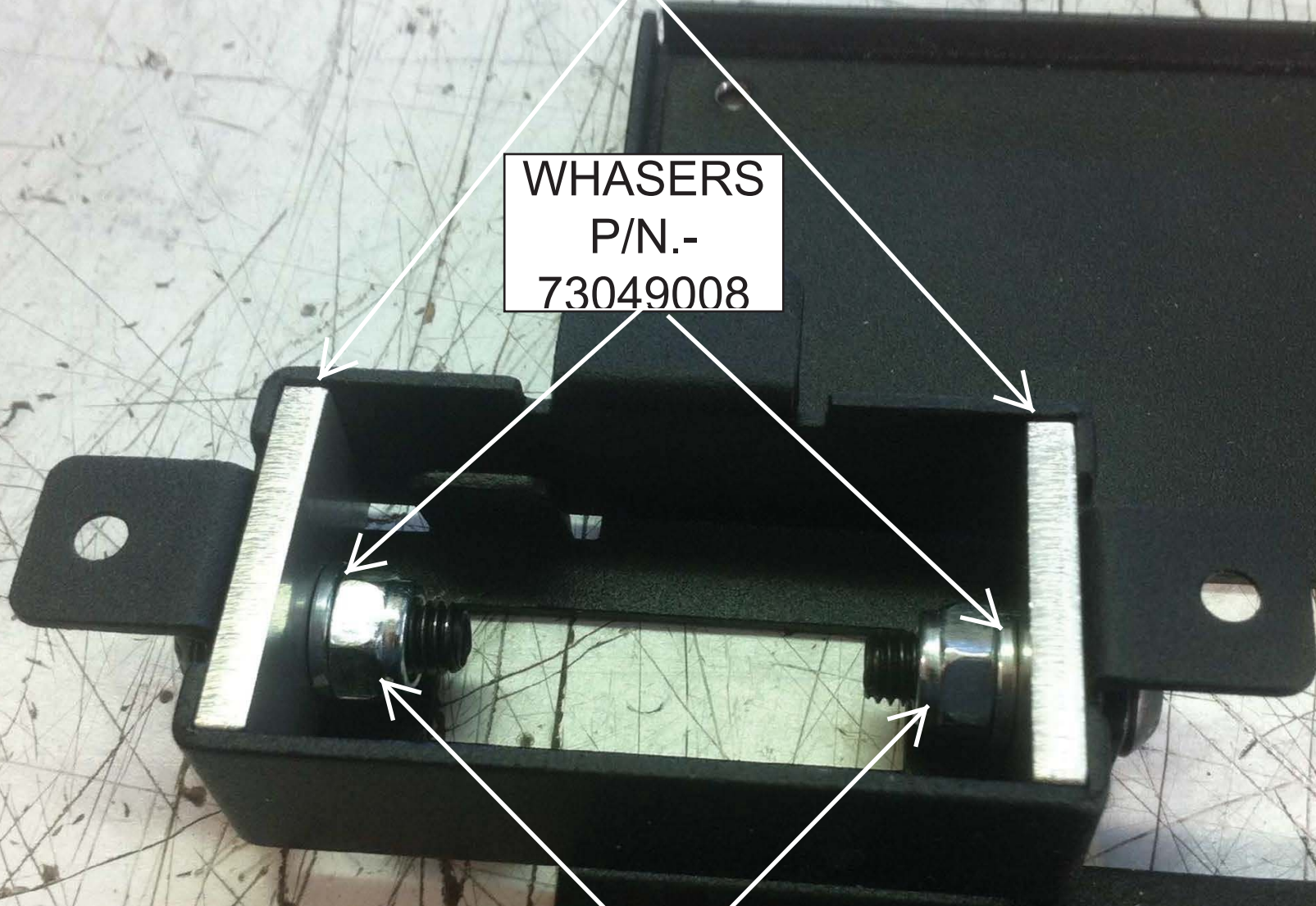

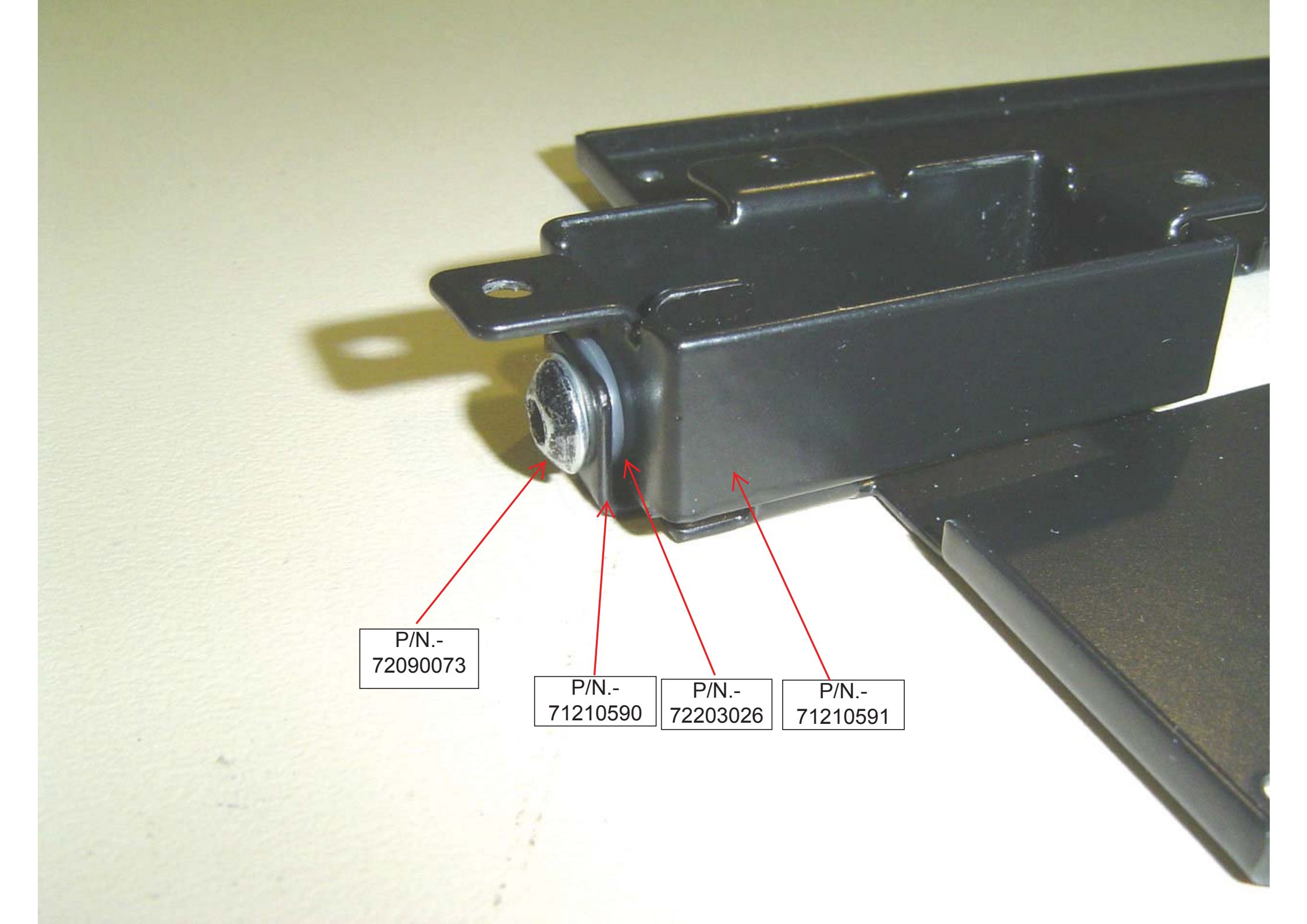

P/N.-
72090073

P/N.-
71210590

P/N.-
72203026

P/N.-
71210591

P/N.-
71210617



P/N.-
71210591



P/N.-
72203026

P/N.-
71210590



P/N.-
71210590



P/N.-
72090073

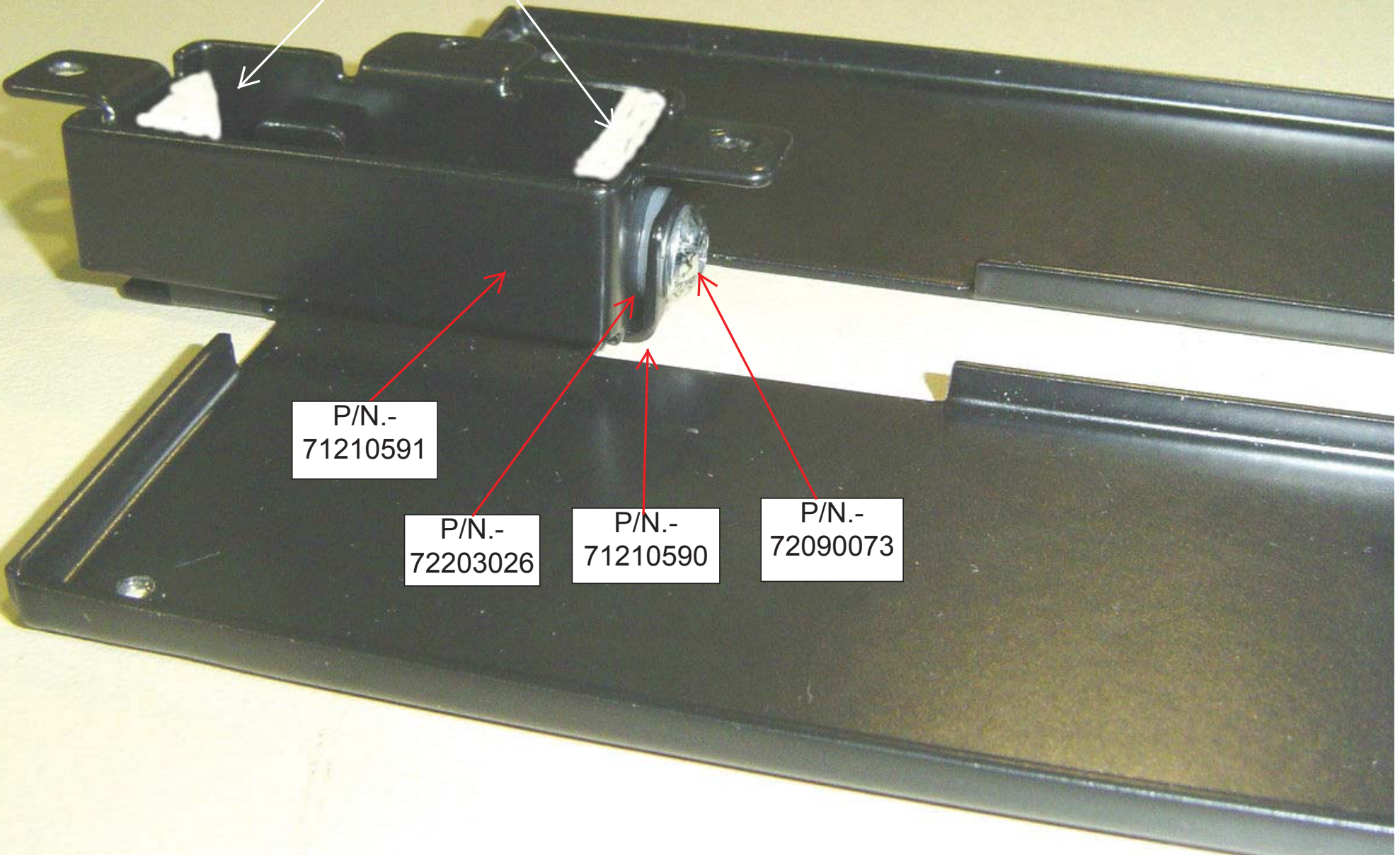

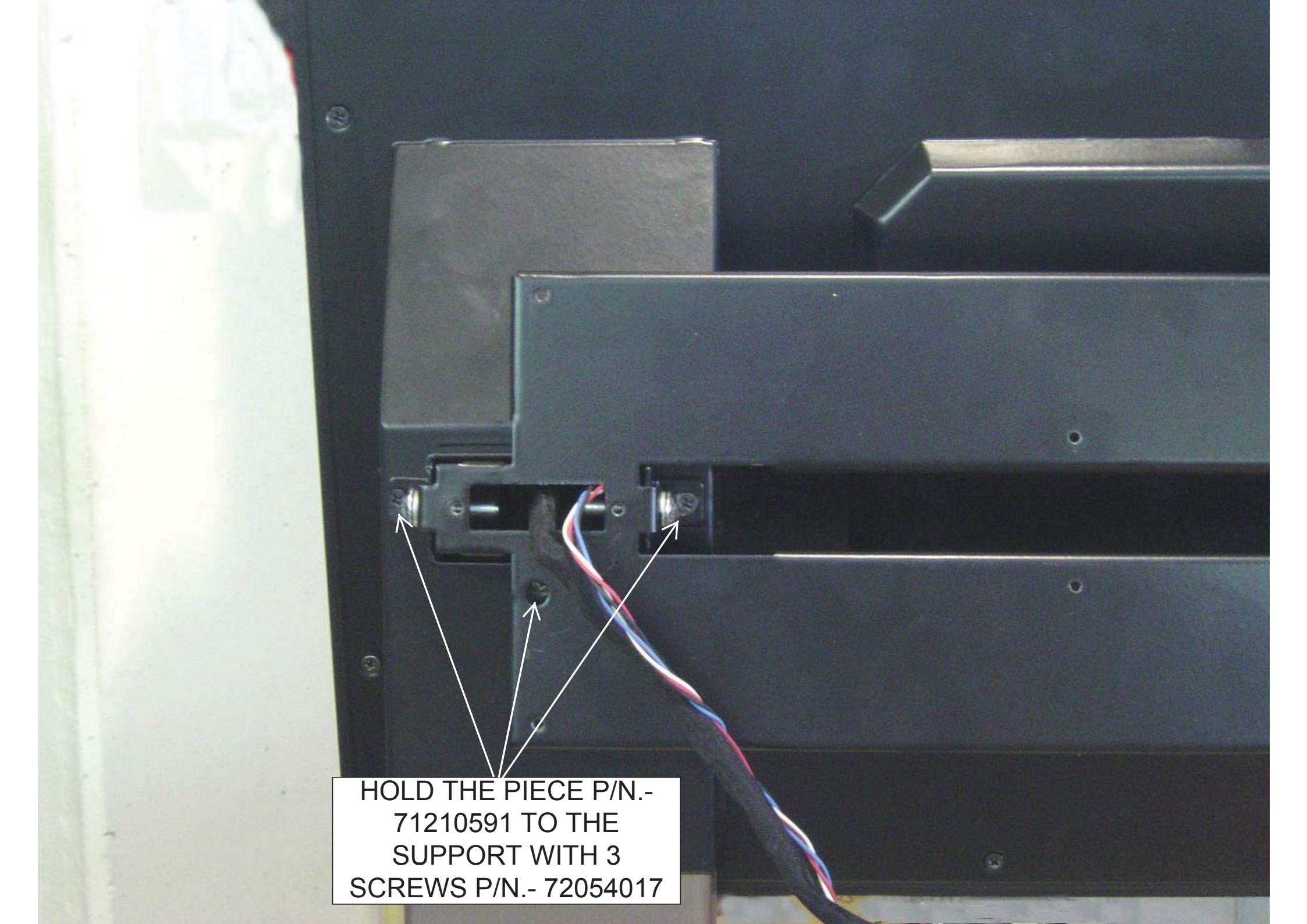
A photograph showing the internal components of a printer, specifically a support structure. A white text box at the bottom contains instructions. Three white arrows point from the text box to three screws on a metal support piece. The support piece is a dark, rectangular metal plate. The printer's body is dark grey or black. A multi-colored ribbon cable is visible, connected to the support structure. The background is a light-colored surface, possibly a wall or a workbench.

HOLD THE PIECE P/N.-
71210591 TO THE
SUPPORT WITH 3
SCREWS P/N.- 72054017

HOLD THE SUPPORT BACK PANEL P/N.- 71210592 WITH 6 SCREWS P/N.- 72032013 AND 2 SCREWS P/N.- 72031015 PUTTING WHASERS.

6 WHASERS P/N.- 73050004
AND 6 SCREWS P/N.-
72032013 (BLACK)

2 WHASERS
P/N.- 73050004
AND 2
SCREWS P/N.-
72031015

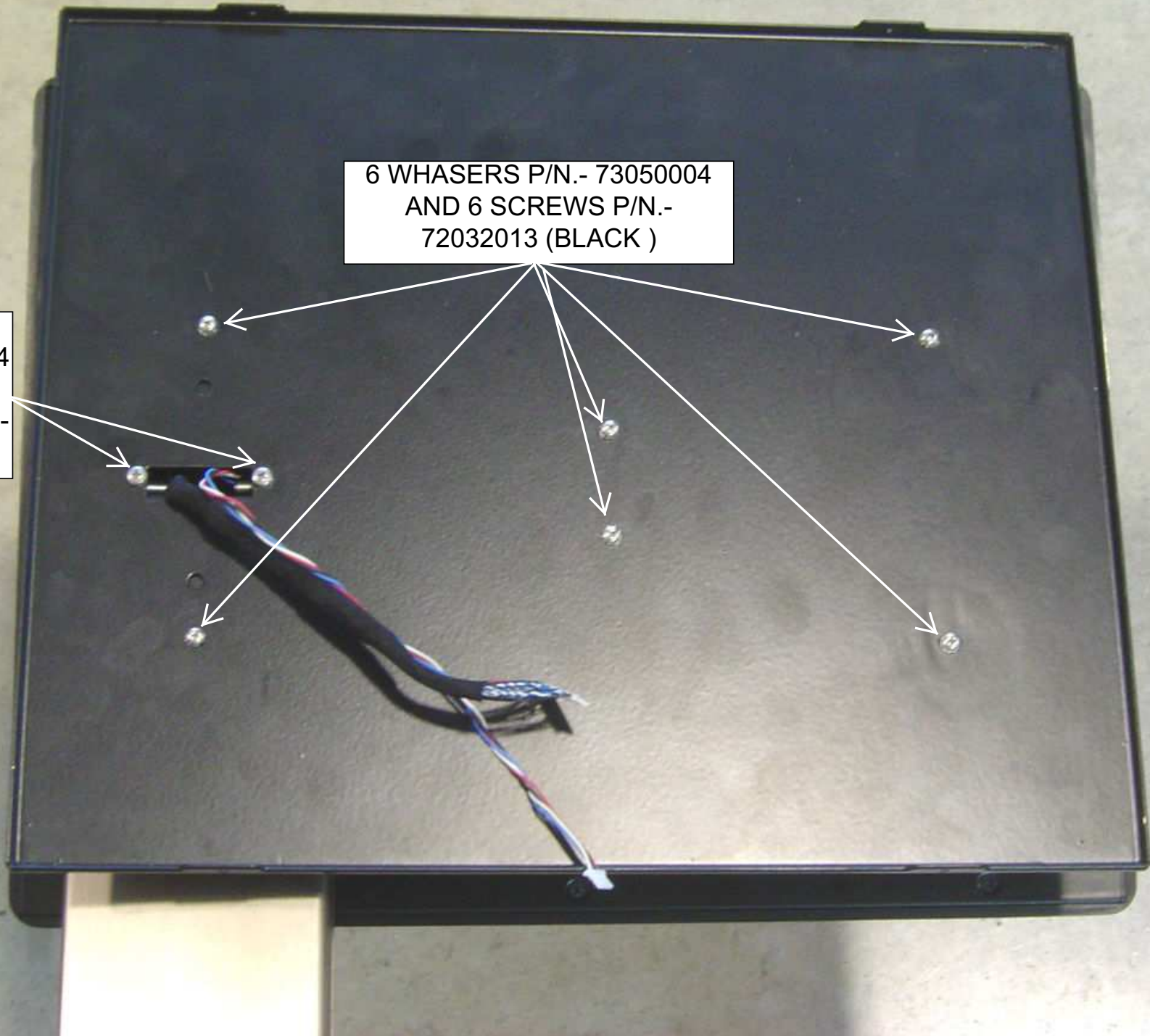

12.- ASSEMBLY AND CONNECT SET BACK MONITOR (COMPONENTS)

P/N.-
19019300

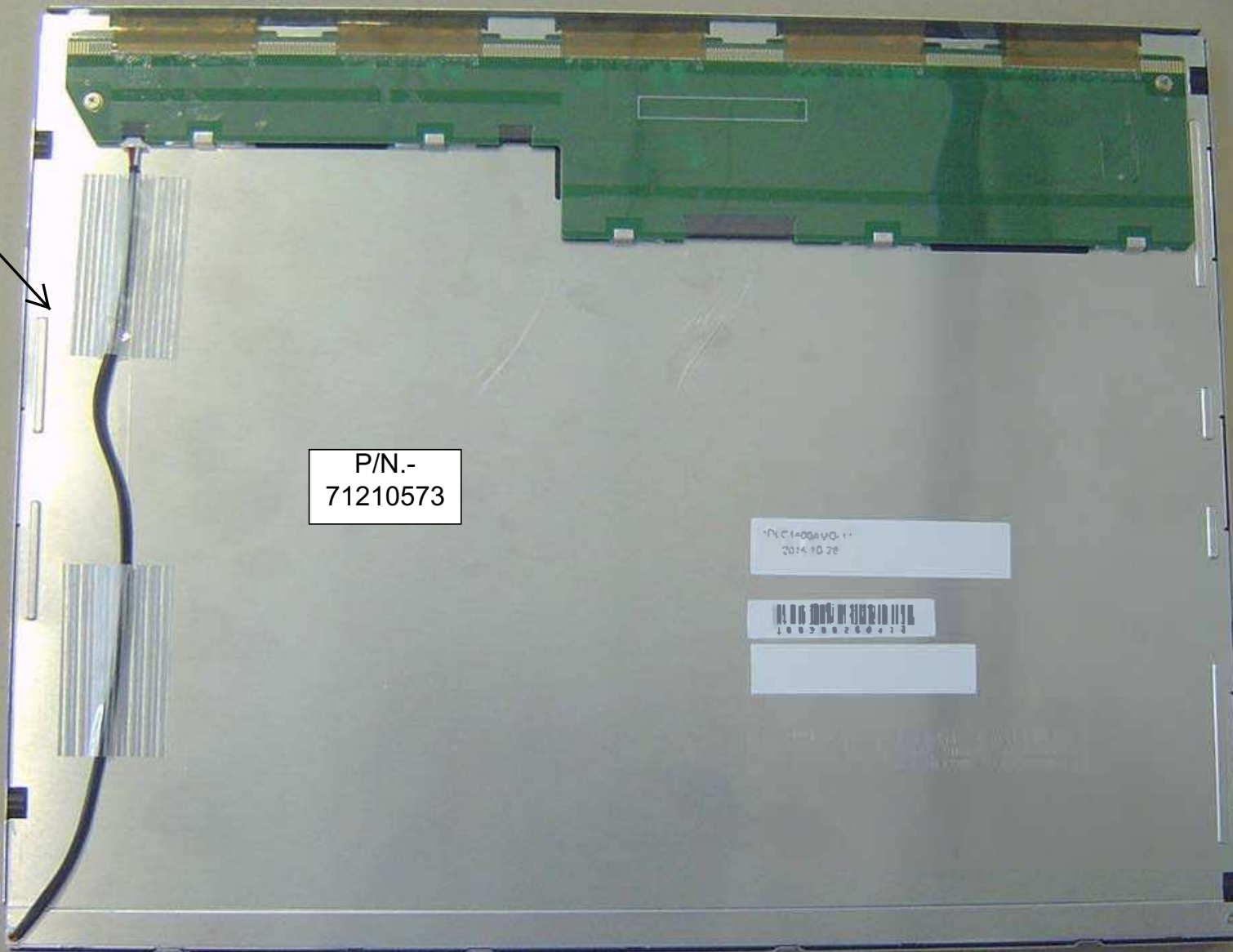

P/N.-
71210573

P/N.- 19019300
2014.10.28

1 805 882 604 1 3

12.- ASSEMBLY AND CONNECT SET BACK MONITOR (COMPONENTS)

P/N.-
71004527

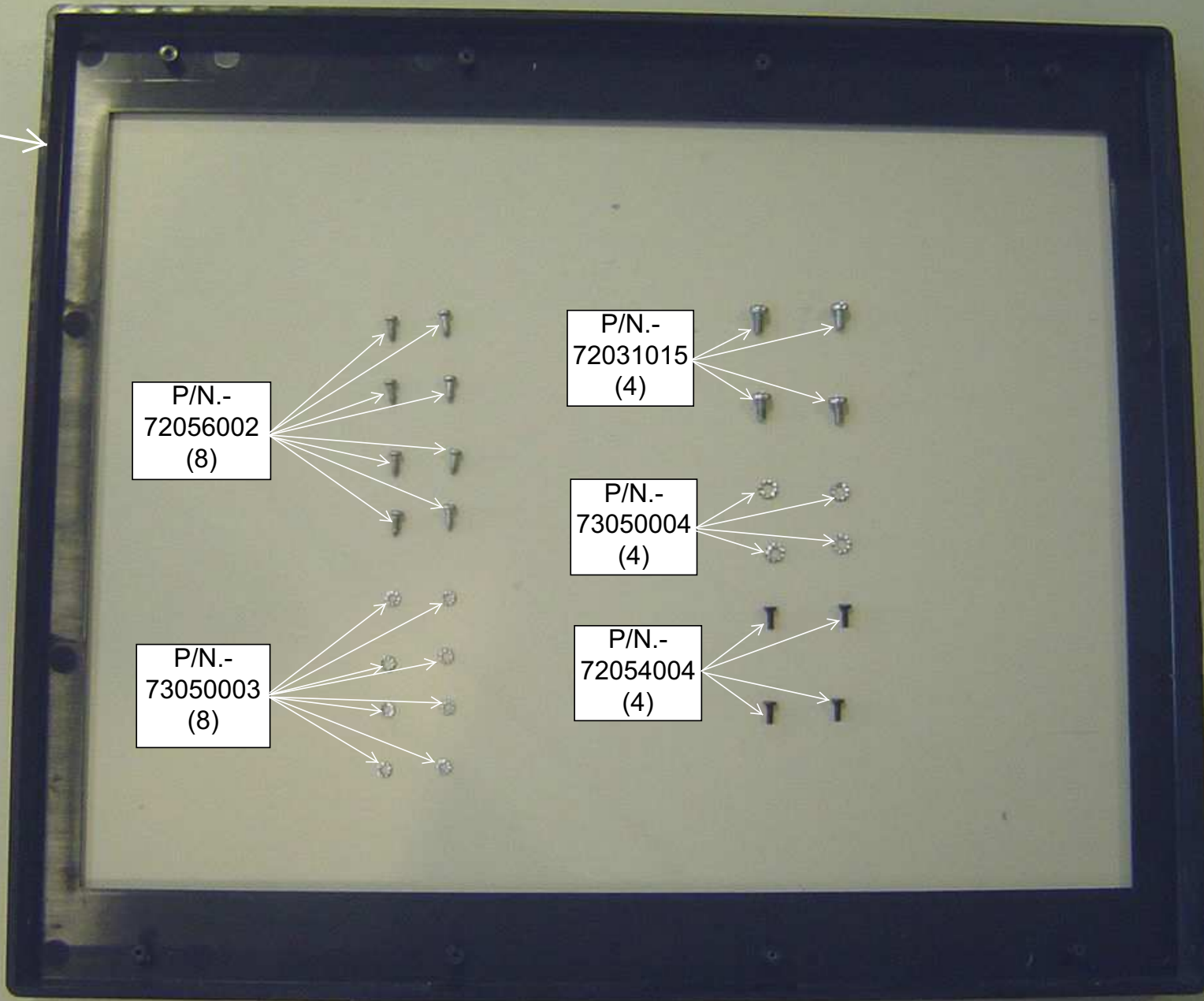

P/N.-
72056002
(8)

P/N.-
72031015
(4)

P/N.-
73050004
(4)

P/N.-
73050003
(8)

P/N.-
72054004
(4)

12.- ASSEMBLY AND CONNECT SET BACK MONITOR (COMPONENTS)

P/N.-
71210573



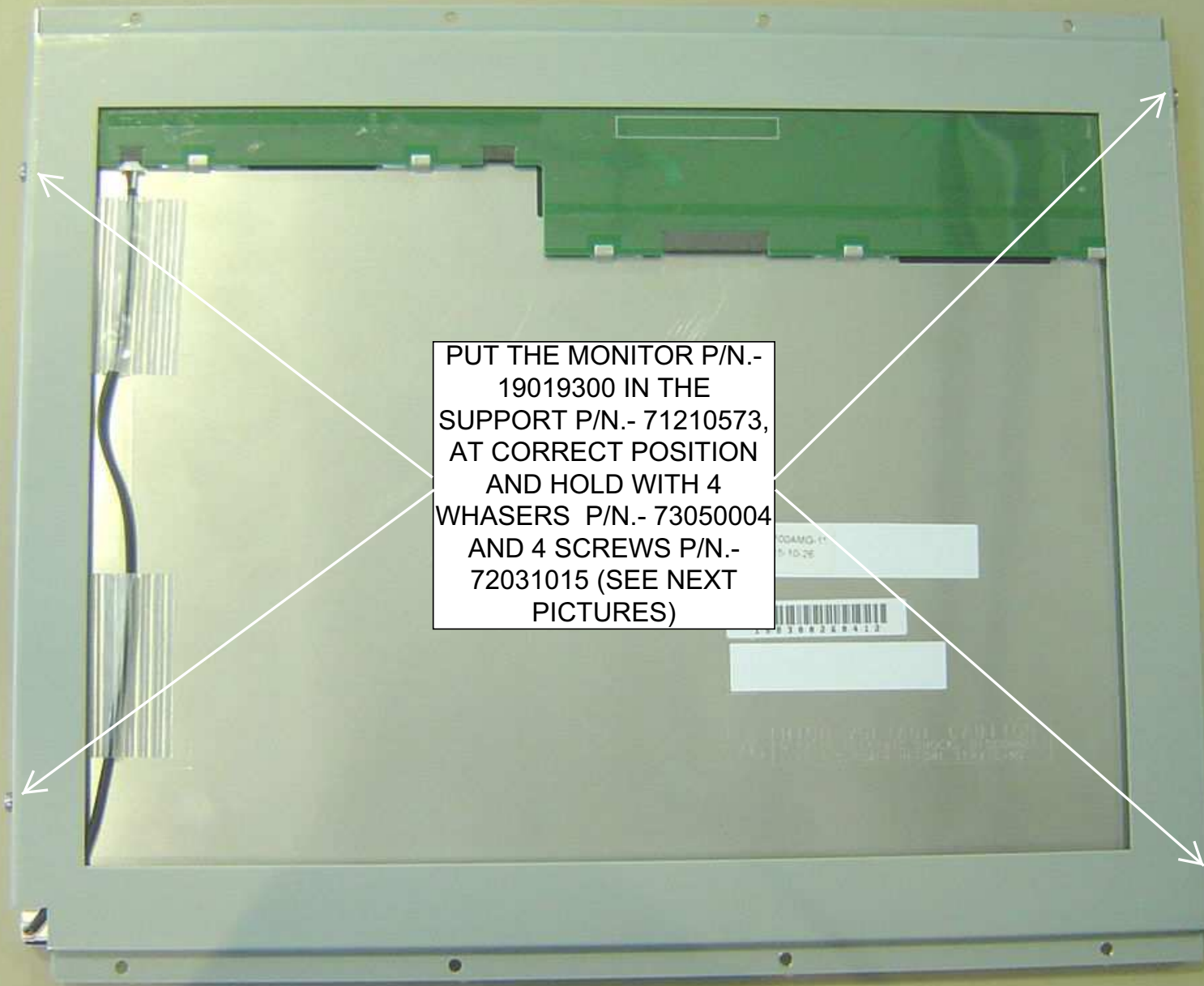

PUT THE MONITOR P/N.-
19019300 IN THE
SUPPORT P/N.- 71210573,
AT CORRECT POSITION
AND HOLD WITH 4
WHASERS P/N.- 73050004
AND 4 SCREWS P/N.-
72031015 (SEE NEXT
PICTURES)

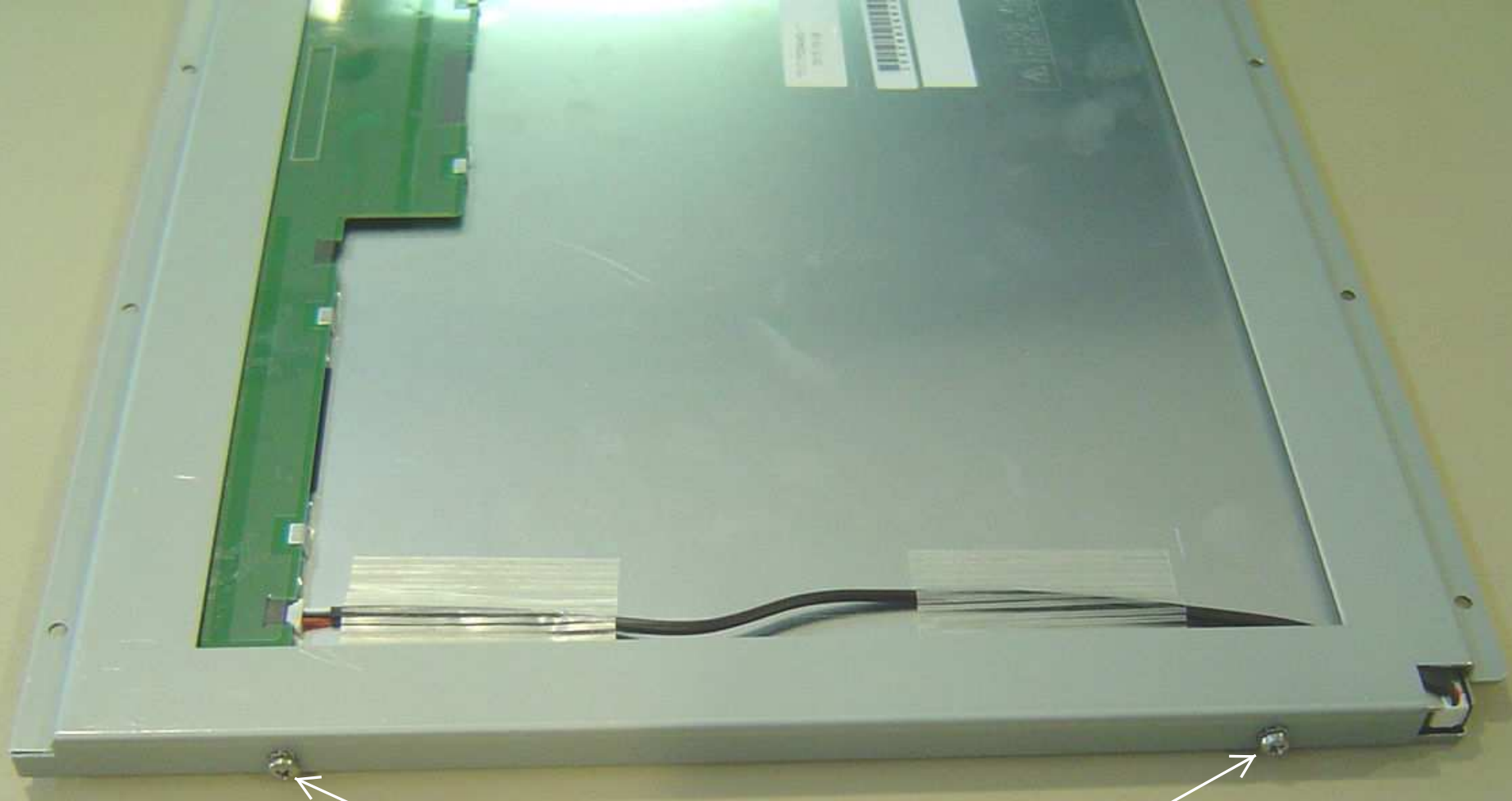

WHASERS P/N.-
73050004 AND
SCREWS P/N.-
72031015



WHASERS P/N.-
73050004 AND
SCREWS P/N.-
72031015

PUTTING THE SUPPORT CENTER, TO AVOID SEE THE EDGE SILVER
(SEE NEXT PICTURE)

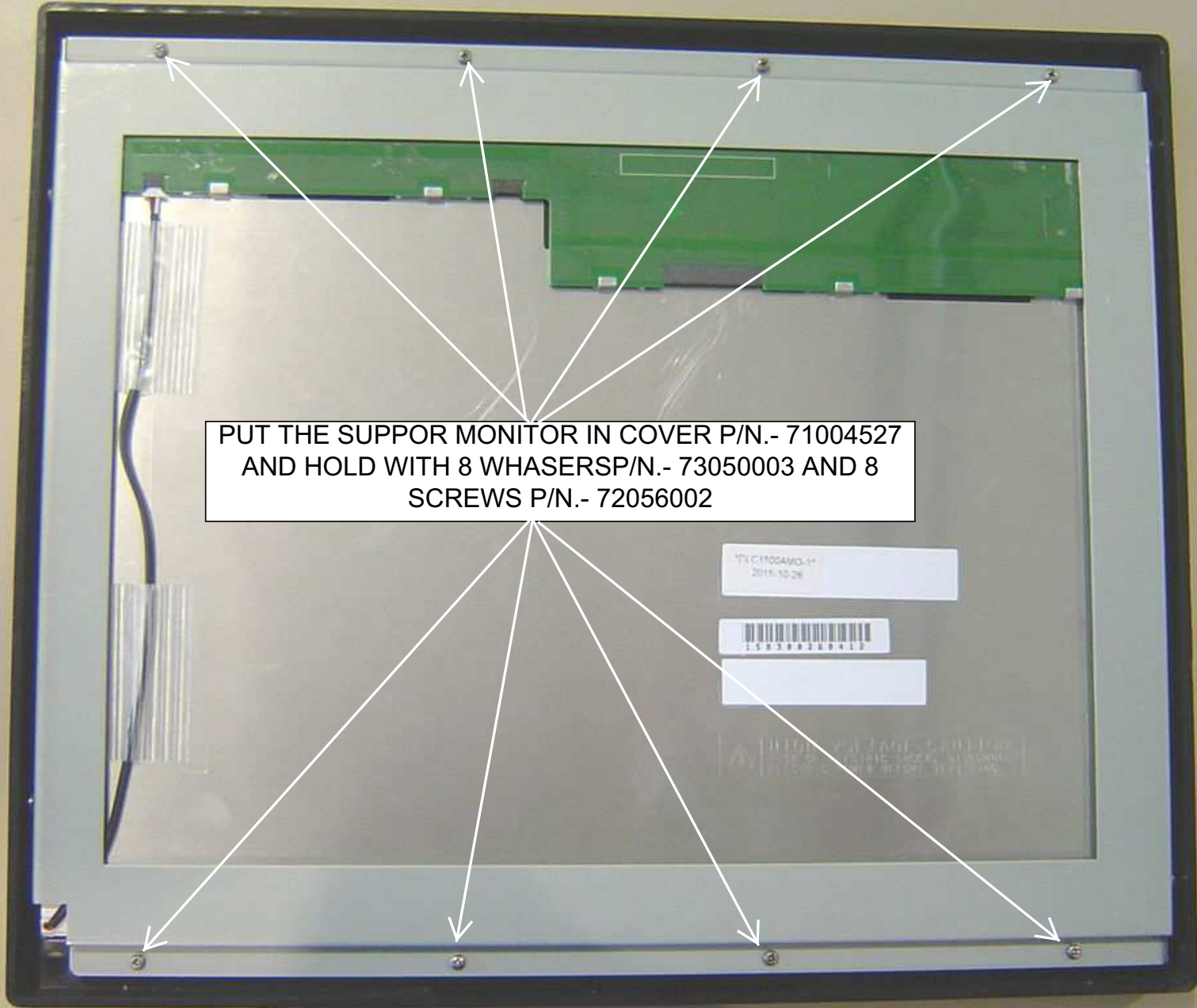

PUT THE SUPPOR MONITOR IN COVER P/N.- 71004527
AND HOLD WITH 8 WHASERSP/N.- 73050003 AND 8
SCREWS P/N.- 72056002

TO PREVENT SEE THE
EDGE SILVER

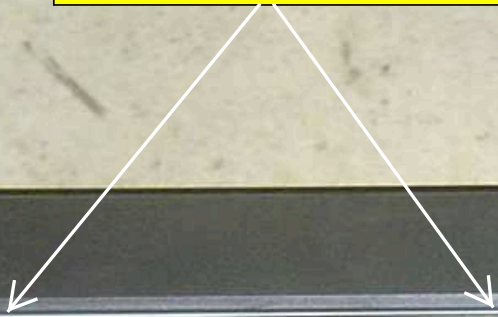



CONNECT THE
CABLES P/N.-
90114093 AND P/N.-
90114094 TO BACK
MONITOR

ASSEMBLY THE HOUSING
MONITOR AT THE
SUPPORT AND HOLD WITH
4 SCREWS P/N.- 72054004
(SEE NEXT PICTURE FOR
BOTTOM PART)

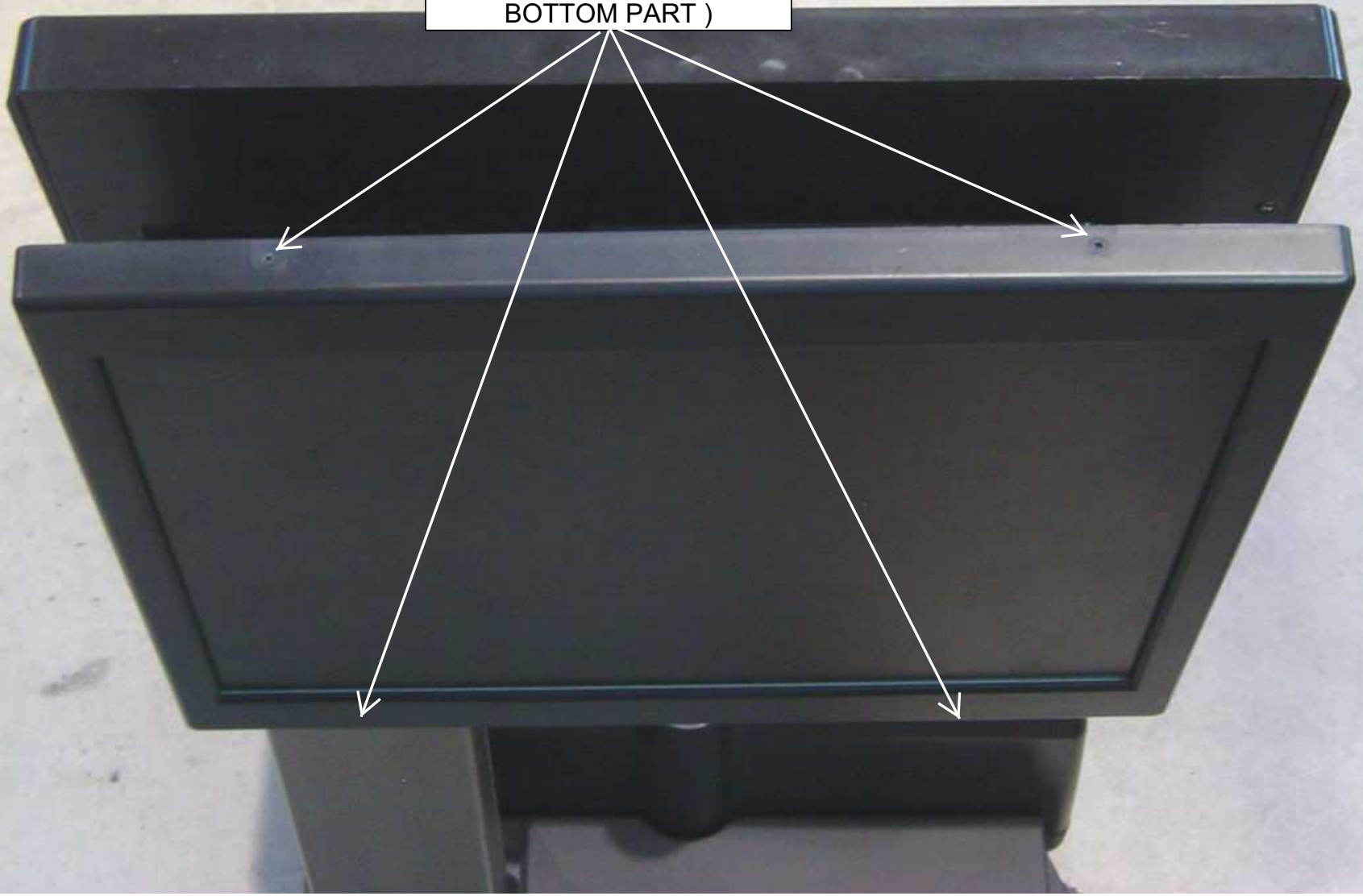



SCREWS P/N.-
72054004

13.- ASSEMBLY SET PRINTER
(COMPONENTS)

P/N.-
71004541

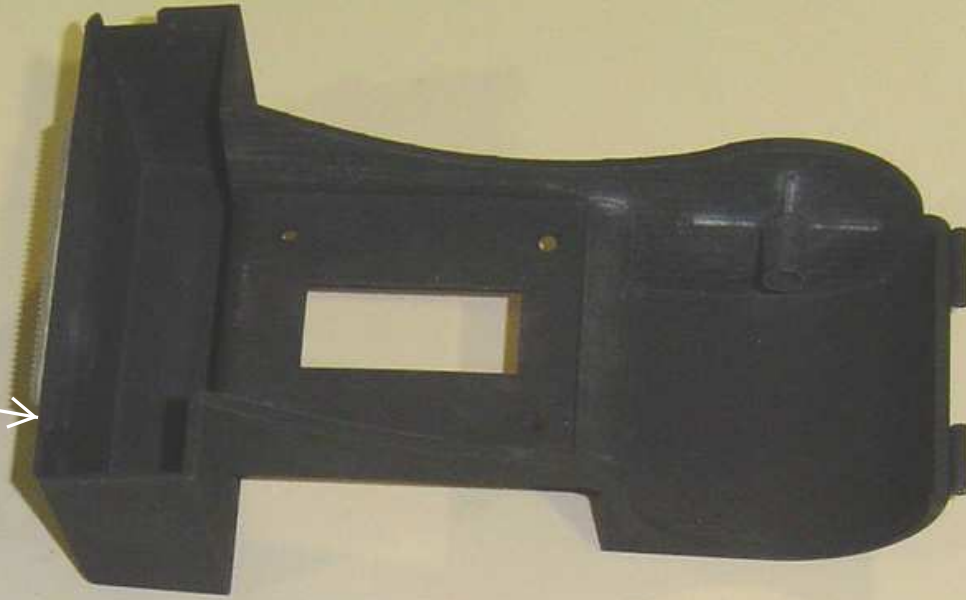

P/N.-
74001007



P/N.-
71004540



13.- ASSEMBLY SET PRINTER (COMPONENTS)

P/N.-
98001055

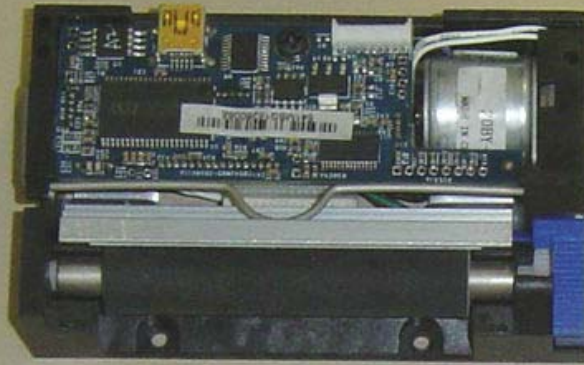

P/N.-
71004539

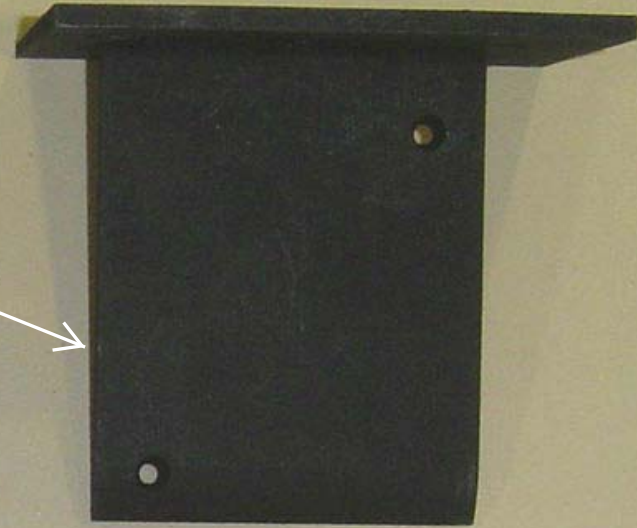

P/N.-
72054017
(2)



P/N.-
72054019
(2)



P/N.-
72056001
(2,2 x 4,5)
(3)



P/N.-
72200009



P/N.-
79001008



JOIN THE PRINTER
CASE P/N.- 71004541
WITH THE COVER P/N.-
71004540 WITH THE
AXLE P/N.- 74001007

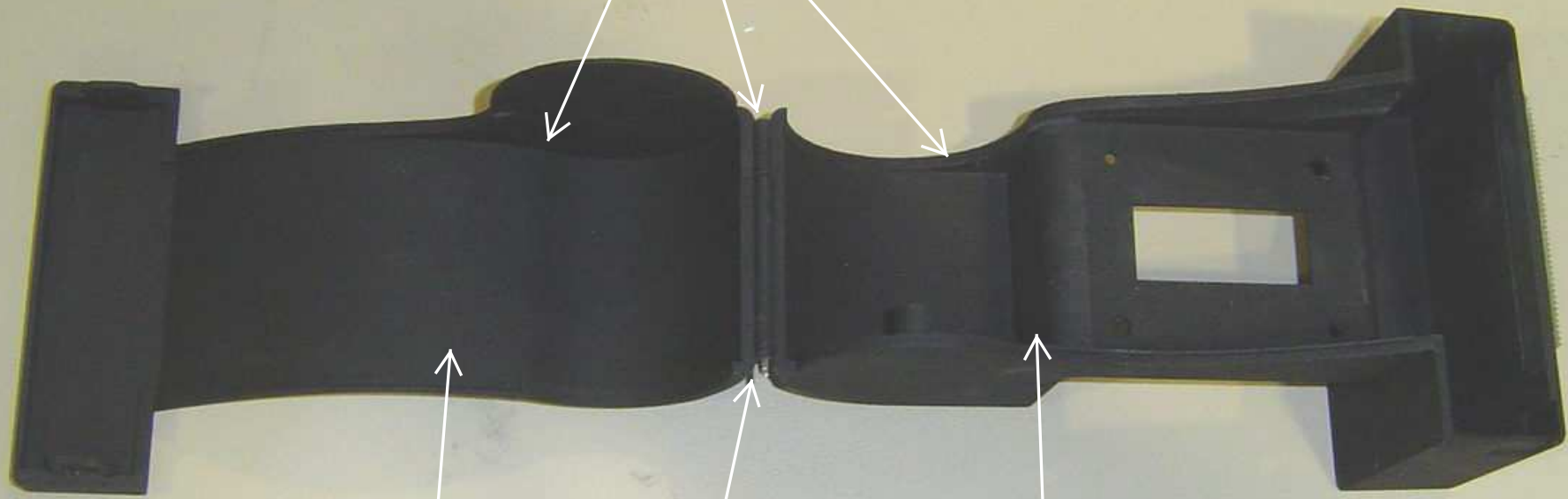

P/N.-
71004540

P/N.-
74001007

P/N.-
71004541

HOLD THE PRINTER P/N.- 98001055 TO THE
SUPPORT P/N.- 71004539 WITH THE
SCREWS P/N.- 72056001

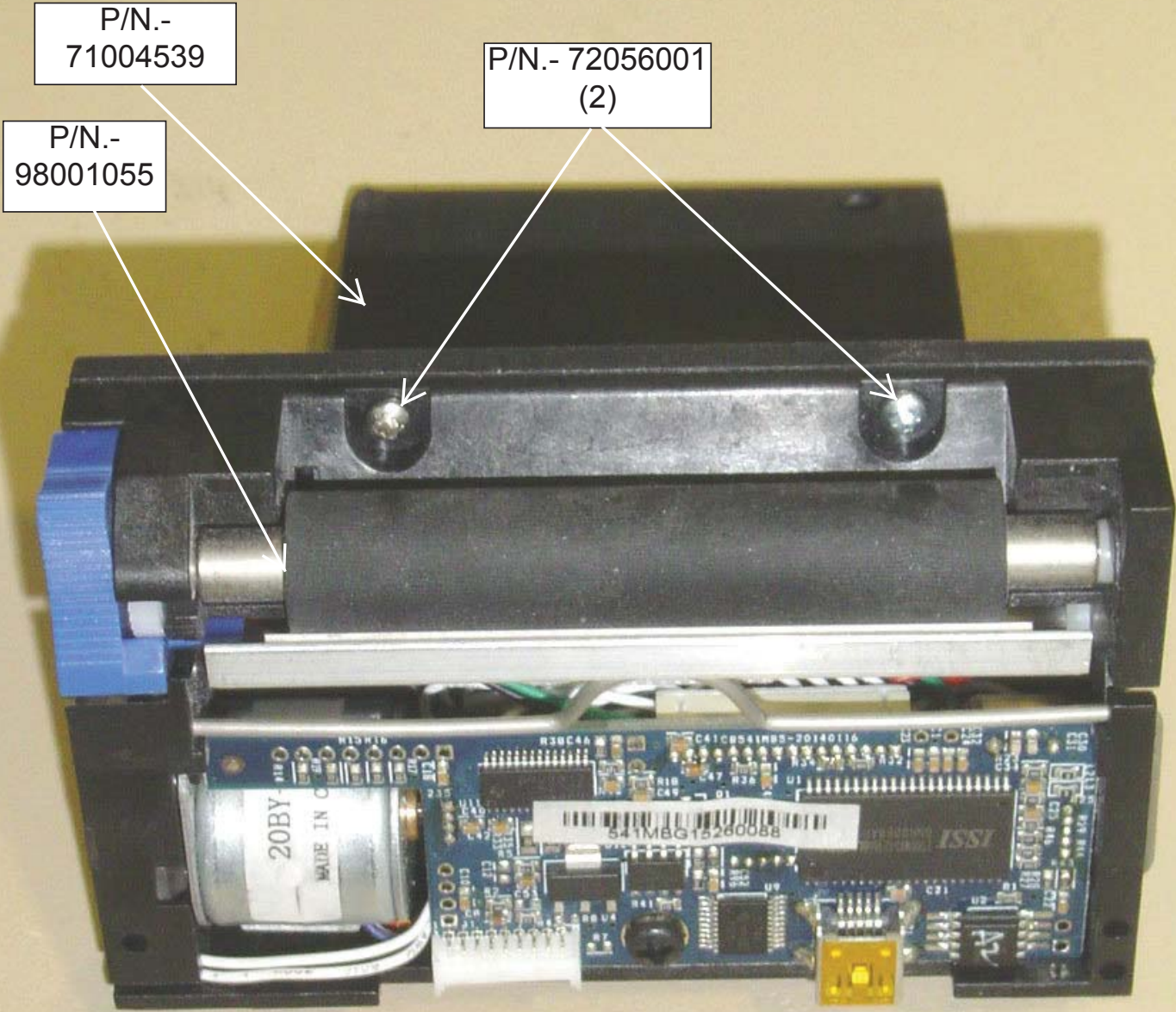

HOLD THE PRINTER WITH THE WHASER
P/N.- 72200009 AND THE SCREW P/N.-
72056001

P/N.-
72200009

P/N.-
72056001



OTHER VIEW OF ASSEMBLY
PRINTER AT SUPPORT





HOLD THE PIECE P/N.-
71004541 TO THE COLUMN
WITH 2 SCREWS P/N.-
72054017, PASSING THE
CABLES

CONNECT THE
CABLE P/N.-90114099
TO PRINTER

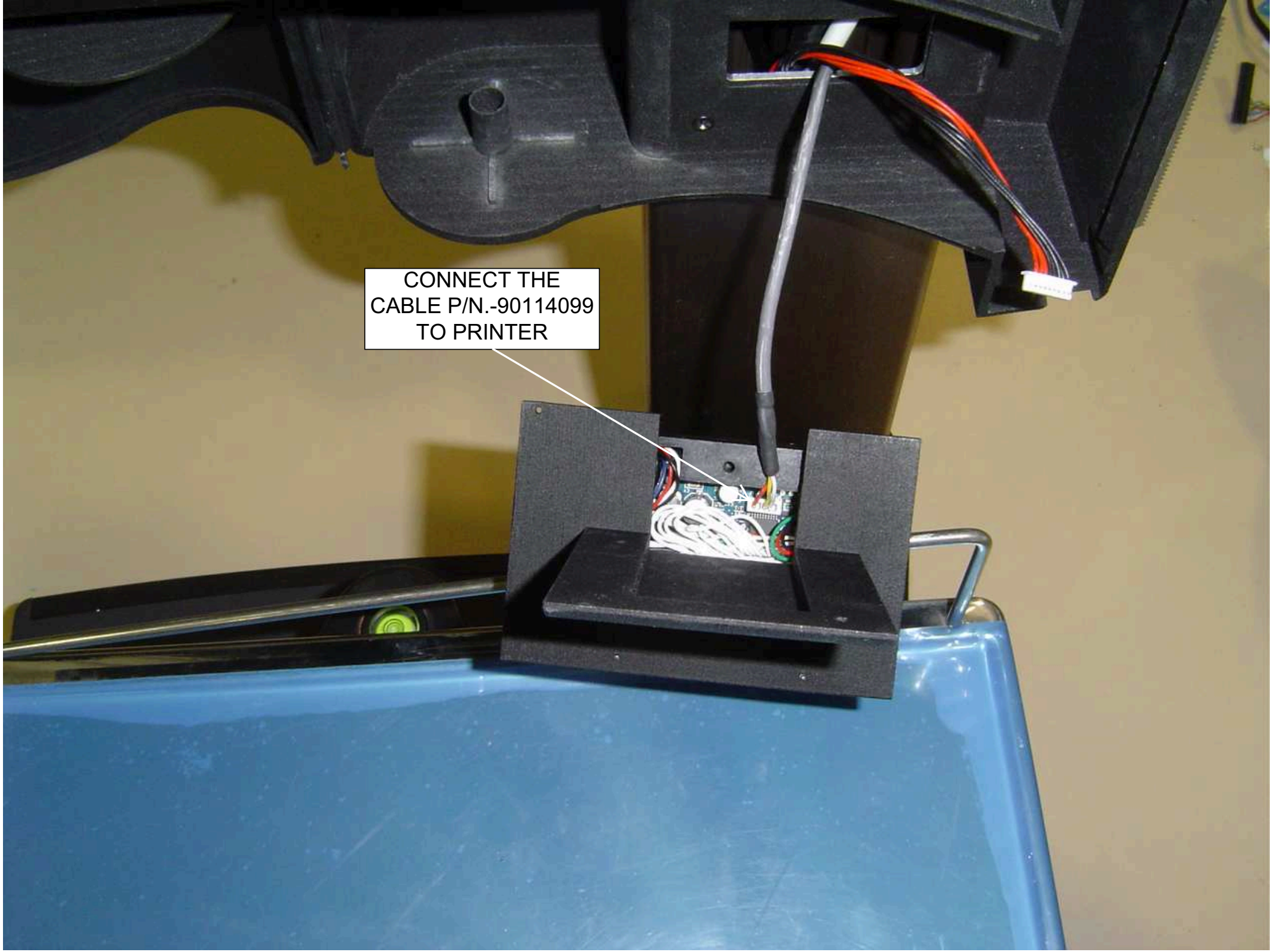

CONNECT THE
CABLE P/N.-90114098
TO PRINTER





ASSEMBLY AND HOLD THE
SUPPORT PRINTER TO THE CASE
WITH 2 SCREWS P/N.- 72054019



PUT PAPER ROLLER,
MOVING LEVER



CLOSE THE
COVER

14.- FINISH

PLIERS FOR SEALING

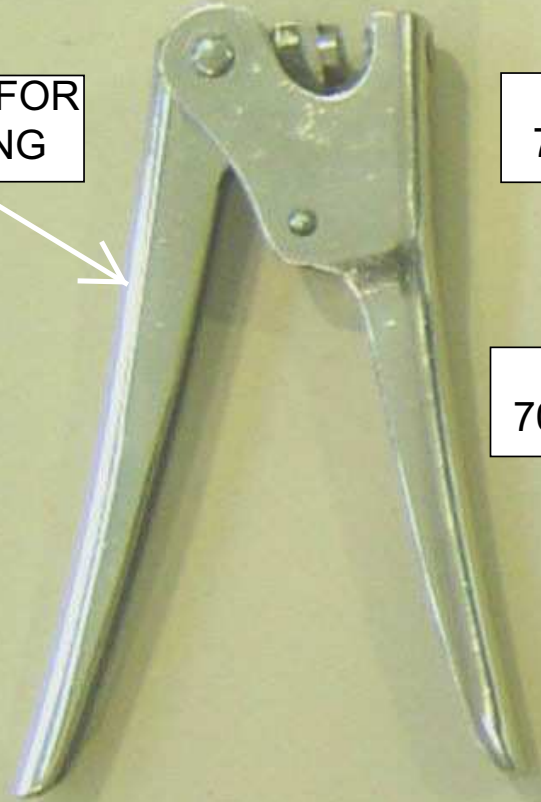

P/N.-
70000868

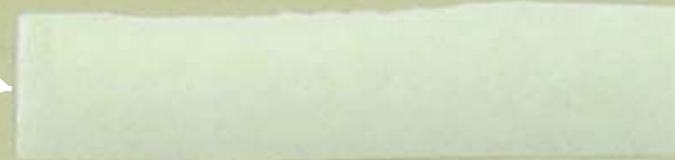

P/N.-
70010374



P/N.-
70000761



SEAL CABLE P/N.-
79500137 (100mm)



PLASTIC SEAL P/N.-
79000016



Man.-G.EPELSA S.L. Cert. nº TB471 Serial nº 888686
C/Punto Nel, 3-28805 Alcalá de Henares-Madrid (Spain)
MODEL:PCSK 110V/240V 50/60Hz I_{max}=1,5A
Max15kg Min100g
T=-9,995kg e=5g



PASTE THE NAME PLATE P/N.-
70010374 AND PASTE UP THE
PROTECTOR P/N.- 70000868

PUT THE CABLE SEAL P/N.-
79500137 AND SEAL P/N.-
79000016, USING PLIERS
FOR SEALING, AFTER
CHECK THE SCALE

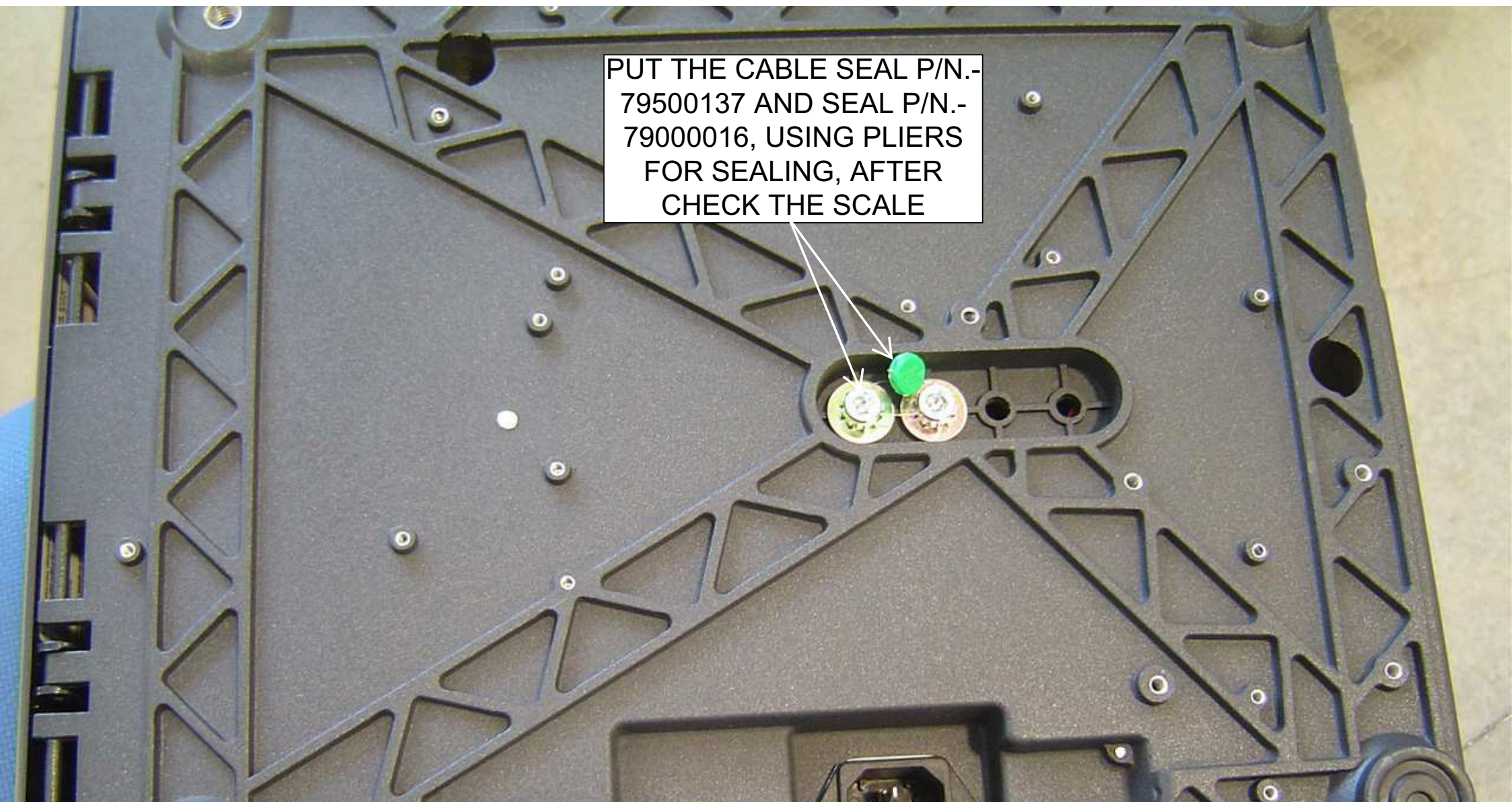

AFTER VERIFY
THE SCALE
PASTE THE
LABEL P/N.-
70000761

